

2020
Introduction of Labs
School of Electrical Engineering

KAIST EE

Circuit Division

| | |
|--|----|
| 1. Prof. Lee-Sup Kim's Lab. (Multimedia VLSI Laboratory) | 1 |
| 2. Prof. Joo-Young Kim's Lab. (CAST Laboratory) | 2 |
| 3. Prof. Hyu-sik Kim's Lab. (Circuit Laboratory) | 3 |
| 4. Prof. Seung-Tak Ryu's Lab. (Mixed-Signal IC Laboratory) | 4 |
| 5. Prof. In-Cheol Park's Lab. (Intelligence Computing Systems Laboratory) | 5 |
| 6. Prof. Hyeon-min Bae's Lab. (Nanoscale Advanced Integrated Systems Laboratory) | 6 |
| 7. Prof. Youngsoo Shin's Lab. (uComputing Laboratory) | 7 |
| 8. Prof. Hoi-Jun Yoo's Lab. (Semiconductor System Laboratory) | 8 |
| 9. Prof. Sang-Gug Lee's Lab. (Nano Intergrated Circuit Expertise Laboratory) | 9 |
| 10. Prof. Wanyeong Jung's Lab. (Smart Energy-Efficient Design Laboratory) | 10 |
| 11. Prof. Minkyu Je's Lab. (Integrated Microsystems Powered with Advanced Circuit Technologies Laboratory) | 11 |
| 12. Prof. SeongHwan Cho's Lab. (Cho's Circuits and Systems Laboratory) | 12 |
| 13. Prof. Jaehyouk Choi's Lab. | 13 |

Communication Division

| | |
|--|----|
| 1. Prof. Joonhyuk Kang's Lab. (Advanced Radio Technology Laboratory) | 17 |
| 2. Prof. Jaekyun Moon's Lab. (Storage, Communications & Machine Learning Laboratory) | 18 |
| 3. Prof. Hyuncheol Park's Lab. (Laboratory for Information Transmission) | 19 |
| 4. Prof. Changho Suh's Lab. (Information Systems Laboratory) | 20 |
| 5. Prof. Youngchul Sung's Lab (Smart Information Systems Research Laboratory) | 21 |
| 6. Prof. Ickho Song's Lab. (Statistical Signal Processing Laboratory) | 22 |
| 7. Prof. Si-Hyun Lee's Lab. (Information Theory, Communications and Security Laboratory) | 23 |
| 8. Prof. Yong Hoon Lee's Lab. (Digital Communications Laboratory) | 24 |
| 9. Prof. Sae-Young Chung's Lab. (Information Theory & Machine Learning Laboratory) | 25 |
| 10. Prof. Hye won Chung's Lab. (Inference and Information for Data Science Laboratory) | 26 |
| 11. Prof. Cho Dong Ho's Lab. (Ubiquitous Mobile Life System Laboratory) | 27 |
| 12. Prof. Wan Choi's Lab. (Wireless Communication Systems Laboratory) | 28 |
| 13. Prof. Junil Choi's Lab. (Intelligent Communications System Laboratory) | 29 |
| 14. Prof. Jeongseok Ha's Lab. (Coding and Communications Laboratory) | 30 |

Computer Division

| | |
|---|----|
| 1. Prof. John Kim's Lab. (Computer Systems and Network Laboratory) | 33 |
| 2. Prof. Song Min Kim's Lab. (Smart and Mobile Systems Laboratory) | 34 |
| 3. Prof. Yongdae Kim's Lab. (System Security Laboratory) | 35 |
| 4. Prof. Park, KyoungSoo's Lab. (Networked and Distributed Computing System Laboratory) | 36 |
| 5. Prof. Seungwon Shin's Lab. (Network and System Security Laboratory) | 37 |
| 6. Prof. Jinwoo Shin's Lab. (Algorithmic Intelligence Laboratory) | 38 |
| 7. Prof. David Hyunchul Shim's Lab. (Unmaned System Reserach Grop) | 39 |
| 8. Prof. Youjip Won's Lab. (Operating System Laboratory) | 40 |
| 9. Prof. Minsoo Rhu's Lab. (Vertically Integrated Architecture Research Grop) | 41 |
| 10. Prof. Chan-Hyun Youn's Lab. (Network and Computing Laboratory) | 42 |
| 11. Prof. Yung Yi's Lab. (LeArning in Networking Algorithm, Design, and Analysis Laboratory) | 43 |
| 12. Prof. Naehyuck Chang's Lab. (CAD4X Laboratory) | 44 |
| 13. Prof. Myoungsoo Jung's Lab. (Computer Architecture Memory Systems Laboratory) | 45 |
| 14. Prof. Song Chong's Lab. (Data Science and Network Laboratory) | 46 |
| 15. Prof. Jun Kyun Choi's Lab. (Media Network Laboratory) | 47 |
| 16. Prof. Dongsu Han's Lab. (Intrlligent Network Architecture and Distributed Systems Laboratory) | 48 |
| 17. Prof. Steven Euijong whang's Lab. (Data Intelligence Laboratory) | 49 |

Device Division

| | |
|--|----|
| 1. Prof. Sanghyeon kim's Lab. (3D integrated opto-electronic device Laboratory) | 53 |
| 2. Prof. Yong-Hoon Kim's Lab. (1st-Principles Nano-Devices Computing Laboratory) | 54 |
| 3. Prof. Chul Soon Park's Lab. (Microwave Microsystems Laboratory) | 55 |
| 4. Prof. Mincheol Shin's Lab. (Computational Nanotechnology Laboratory) | 56 |
| 5. Prof. Kyoungsoon Yang's Lab. (High Speed Nano Electronics Laboratory) | 57 |
| 6. Prof. Seunghyup Yoo's Lab. (Integrated Organic Electronics Laboratory) | 58 |
| 7. Prof. Giwan Yoon's Lab (Terahertz Nano System Laboratory) | 59 |
| 8. Prof. Jun-Bo Yoon's Lab. (3D Micro-Nano Structures Laboratory) | 60 |
| 9. Prof. Jung-Yong Lee's Lab. (Advance Devices for Energy Conversion Laboratory) | 61 |
| 10. Prof. Hyunjoo Lee's Lab. (Brain/Bio Medical Microsystem Laboratory) | 62 |
| 11. Prof. Sanghun jeon's Lab. (ANTONIS Laboratory) | 63 |
| 12. Prof. Jae-woong Jeong's Lab. (Bio-Integrated Electronics and System Laboratory) | 64 |
| 13. Prof. Byung Jin Cho's Lab. (Nano Electronics & Energy Device Laboratory) | 65 |
| 14. Prof. Kyung Cheol Choi's Lab. (Advanced Display and Nano Convergence Laboratory) | 66 |
| 15. Prof. Sung-Yool Choi's Lab. (Molecular & Nano Device Laboratory) | 67 |
| 16. Prof. Shinhyun Choi's Lab. (Emerging Nanotechnologies and Integrated Systems Laboratory) | 68 |
| 17. Prof. Yang-Kyu Choi's Lab. (Advanced Neuromorphic & Nano Device Laboratory) | 69 |
| 18. Prof. Sungcheol Hong's Lab (Wave Embedded Integrated Systems Laboratory) | 70 |

Signal Division

| | |
|---|----|
| 1. Prof. In So Kweon's Lab. (Robotics and Computer Vision Laboratory) | 73 |
| 2. Prof. Dae-Shik Kim's Lab. (Brain Reverse Engineering and Imaging Laboratory) | 74 |
| 3. Prof. Munchurl Kim's Lab. (Video and Image Computing Laboratory) | 75 |
| 4. Prof. Jong-Hwan Kim's Lab. (Robot Intelligence Technology Laboratory) | 76 |
| 5. Prof. Junmo Kim's Lab. (Statistical Inference and Information Theory Laboratory) | 77 |
| 6. Prof. Changick Kim's Lab. (Computational Imaging Laboratory) | 78 |
| 7. Prof. Hoirin Kim's Lab (Statistical Speech & Sound Computing Laboratory) | 79 |
| 8. Prof. Yong Man Ro's Lab. (Image and Video Systems Laboratory) | 80 |
| 9. Prof. Hyun Myung's Lab. (Urban Robotics Laboratory) | 81 |
| 10. Prof. Gun-Woo Moon's Lab. (KAIST Power Electronics Laboratory) | 82 |
| 11. Prof. HyunWook Park's Lab. (Image Computing System Laboratory) | 83 |
| 12. Prof. Chang Dong Yoo's Lab. (Artificial Intelligence & Machine Learning Laboratory) | 84 |
| 13. Prof. Young-Gyu Yoon's Lab. (Neuro-Instrumentation and Computational Analysis Laboratory) | 85 |
| 14. Prof. Dong Eui Chang's Lab. (Control Laboratory) | 86 |
| 15. Prof. Jung-Woo Choi's Lab. (Smart Sound Systems Laboratory) | 87 |
| 16. Prof. Minsoo Hahn's Lab (Speech and Audio Information Laboratory) | 88 |

Wave Division

| | |
|---|-----|
| 1. Prof. Jounggho Kim's Lab. (Terahertz Interconnection and Package Laboratory) | 91 |
| 2. Prof. Hoon Kim's Lab. (Photonics Systems Research Laboratory) | 92 |
| 3. Prof. Seong-Ook Park's Lab. (Micro Millimeter and Antenna Laboratory) | 93 |
| 4. Prof. Hyo-Hoon Park's Lab. (Smart Sensor Systems Laboratory) | 94 |
| 5. Prof. Joonwoo Bae's Lab. (QIT@KAIST Laboratory) | 95 |
| 6. Prof. Yonghyub Won's Lab. (Convergence Optoelectronic Device Engineering Laboratory) | 96 |
| 7. Prof. Kyoungsik Yu's Lab. (Integrated Nanophotonics Laboratory) | 97 |
| 8. Prof. Jong-Won Yu 's Lab. (Radio Frequency System Solution Laboratory) | 98 |
| 9. Prof. June-Koo Rhee's Lab. (Quantum Information and Communications Laboratory) | 99 |
| 10. Prof. Chang-Hee Lee's Lab. (LiDARs & Intelligent Optical Nodes Laboratory) | 100 |
| 11. Prof. Min Seok Jang's Lab. (Nanophotonics Laboratory) | 101 |
| 12. Prof. Yun Chur Chung's Lab. (Lightwave Systems Research Laboratory) | 102 |

Circuit Division





■ **Contact information**

Professor : NanoFab Center (E19) S-204 TEL : 042-350-3460
 Lab. : NanoFab Center (E19) S-204 TEL : 042-350-8060
 Website : <http://mvlsi.kaist.ac.kr>

■ **Current state of the Lab. (in 2019 Fall Semester)**

Postdoctoral Fellows : 1 PhD Students: 7 Master's Student: 7

■ **Research Areas**

[Deep Learning & Neural Network Processor Design]

Deep learning algorithm is getting a huge attention recently. GPUs are widely used to run neural networks, but it is not appropriate to be integrated in mobile devices like smartphones, wearable devices, and drones because of its low energy-efficiency. We focuses on the design and implementation of a dedicated neural network processor in a both high-performance and energy-efficient way. To this end, researches on the datapath and memory architecture optimized for neural network, a flexible hardware architecture to handle a wide variety of neural network models, and hardware-friendly neural network algorithm are being performed. Finally, a neural network processor chip based on our ideas is designed, fabricated, and tested. We are performing state-of-the-art researches at the most recognized conference.

[Processing in-Memory for Deep Learning]

The conventional Von-Neumann architecture severely suffers from memory bottleneck issue in processing memory-dominant deep learning algorithms since massive amount of data should be transferred through the narrow bus from the main memory to the processor. Meanwhile, processing in-memory (PIM) technique which obeys Non-Von Neumann architecture processes data in the memory and transfers only necessary data to the processor, reducing the energy cost of memory transfers. Therefore, processing in-memory paradigm is the key direction and the next generation platform for efficient processing of large-scale deep neural networks.

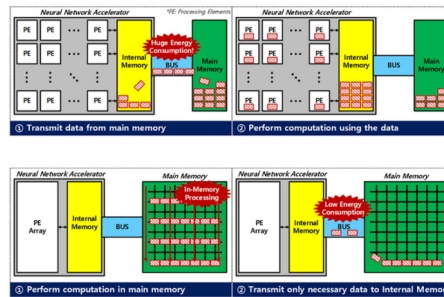
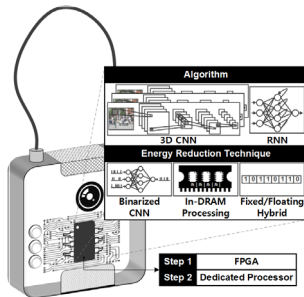

■ **Recommended courses & Career after graduation**

- ▷ Recommended courses: Digital System, Computer Architecture, Digital Integrated Circuit, Computer Vision, Courses related to Deep Learning & Neural Network
- ▷ Career: Semiconductor Industries and Institutes (Samsung, SK hynix, Qualcomm, NVIDIA, ETRI, etc.)

■ **Introduction to other activities besides research**



- ▷ Coffee break after lunch
- ▷ Various hobbies with members
- ▷ Sports like soccer, badminton, ping-pong and so on
- ▷ Annual summer/winter field trips

■ **Introduction to the Lab.**

We perform a wide range of researches that covers whole SoC design parts including digital processors, memory architectures, and analog circuits. This is our own unique strength that you never see in other laboratories. Therefore, we have a great research environment to bring yourself to a brilliant processor engineer with a capability to design a whole processor system. Our members are encouraged to perform their own researches with freedom in a family-like atmosphere. As a result, we produce the state-of-the-art research performances with international conference and journal papers.

■ **Recent research achievements ('19)**

- [1] The most recognized conference: Hyeonuk Kim, Jaehyeong Sim, Yeongjae Choi, Lee-Sup Kim, "NAND-Net: Minimizing Computational Complexity of In-Memory Processing for Binary Neural Networks", IEEE International Symposium on High-Performance Computer Architecture, Jan 2019
- [2] The most recognized conference: Seungkyu Choi, Jaekang Shin, Yeongjae Choi, Lee-Sup Kim, "An Optimized Design Technique of Low-bit Neural Network Training for Personalization on IoT Devices", ACM/IEEE Design Automation Conference, Jun 2019

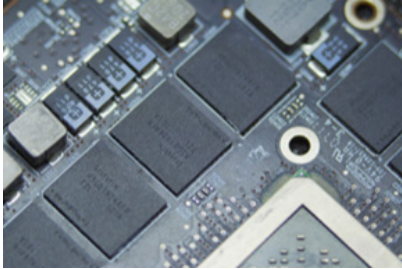
| | | |
|---|---|---|
| <h1>CAST Lab</h1> <p>(Circuits, Architecture, Systems, Technology)</p> | | <p>■ Contact information</p> <p>Professor : E3-2 #4202 TEL : 042-350-7461 Lab. : E3-2 #4209 TEL : TBD Website : http://castlab.kaist.ac.kr</p> |
| <p>■ Current state of the Lab. (in 2019 Fall Semester)</p> <p>Postdoctoral Fellows : 0 PhD Students: 1 Master's Student: 1</p> | | |
| <p>■ Research Areas</p> | | |
| <p>1. Next Generation AI Processor</p> <p>Machine Learning (ML) revolutionizes how computers handle cognitive tasks based on a massive amount of observed data. As more industries are adopting the technology, we are facing fast-growing demand for hardware support to enable faster and more energy efficient processing. However, latest hardware solutions are often limited to a few popular algorithms such as Multi-Layer Perceptron (MLP), Convolutional Neural Networks (CNN), and Recurrent Neural Networks (RNN). We will focus on hardware support for next generation AI/ML scenarios such as unsupervised learning and reinforcement learning.</p>  | <p>2. Datacenter SoC</p> <p>Cloud computing is rapidly changing how enterprises run their services. Hardware specialization for a massive number of datacenter servers makes economic sense as its energy saving effect will be magnified by the number of servers.</p>  <p>Although it is difficult to find dominant applications in datacenter, network and storage layer tend to have shared data processing pipelines across the workloads. We aim to develop a specialized system-on-chip that not only accelerates common network and storage processing but also provide direct paths between virtual machines and network and storage devices in datacenters.</p> | <p>3. Memory Centric Computing</p> <p>Traditionally CPU is the center of the computing systems while a few layers of memory are built around it to feed the data. However, as compute unit gets much faster than memory unit with technology scaling, it is no longer the most time and energy consuming part of the system. Instead, the cost of moving data to the locations where computations happen becomes the bottleneck. Memory centric model takes an opposite approach to traditional compute centric model to solve this expensive data movement problem: data stays in different storage levels but the processing engines around them perform computations to avoid data movement across the hierarchy.</p>  |
| <p>■ Recommended courses & Career after graduation</p> <ul style="list-style-type: none"> - Recommended Courses: Digital System Design (EE303), Computer Architecture (EE312), Digital Electronic Circuits (EE372), Courses related to deep learning algorithms. - Career: Silicon companies (Samsung, Apple, IBM) and IT companies (Microsoft, Google, Facebook). | <p>■ Introduction to other activities besides research</p> <ul style="list-style-type: none"> - You will have chances to work with various international research organizations such as Microsoft Research, IBM, University of Washington, etc. This can lead you to internship opportunity as well as full-time employment. - You will get a modern workspace and various language skill development resources. | |
| <p>■ Introduction to the Lab.</p> <p>Mission statement: We aim to innovate modern computing systems through hardware specialization. To this end, we are focusing on co-design of multiple layers of computing system such as application, architecture, circuit and technology.</p> | | |
| <p>■ Recent research achievements ('17~'19)</p> <p>We just started. You can make a history with us! Please see Prof. Kim's selected previous publications below:</p> <p>"A Cloud-Scale Acceleration Architecture," International Symposium on Microarchitecture (MICRO), 2016. "Toward Accelerating Deep Learning at Scale Using Specialized Logic," Hot Chips, 2015. "A 201.4GOPS 496mW Real-Time Multi-Object Recognition Processor with Bio-Inspired Neural Perception Engine," JSSC, 2010.</p> | | |

Circuit Lab

Electrical Engineering | KAIST

Contact information

Professor : Room #4223, E3-2 TEL : 042-350-7457
 Lab. : Room #4226, E3-2 TEL : 042-350-5424
 Website : <https://www.ICdesignLab.net/>

Current state of the Lab. (in 2019 Fall Semester)

Ph.D. Students : 5 Master/Ph.D.-Integrated Students: 1 Master's Student: 5

Research Areas

Our research group is focused on innovations in the CMOS integrated chip designs of analog IC, DDI, PMIC, ROIC, and CIS. And, ultimately we plan to build a complete system-on-a-chip solution by incorporating our knowledge in those fields.

Power Conversion and Management IC (PMIC)

- Switch-mode DC-DC power converter using inductive, capacitive, and hybrid techniques
- Fully-monolithic high-speed switching PMIC for modern SoCs
- Energy-harvesting interface circuit and system
- Fast-response high-PSR low-dropout (LDO) regulator
- Battery charger and management circuit

Display Driving Circuits and Systems

- High-resolution area-efficient digital-to-analog converter (DAC)
- OLED display driver with pixel-readout and active-compensation
- Low-power high-speed output driving buffer amplifier
- Fully-integrated system-on-wafer (SoW) for micro-LED displays
- Displays with touch-sensing functionality

Readout IC (ROIC) and Imaging Sensor

- Low-noise high-sensitivity readout circuit and system
- Ultra-high-speed time-delayed integration (TDI) image sensor
- Photon-counting detector for nuclear particles and X-ray

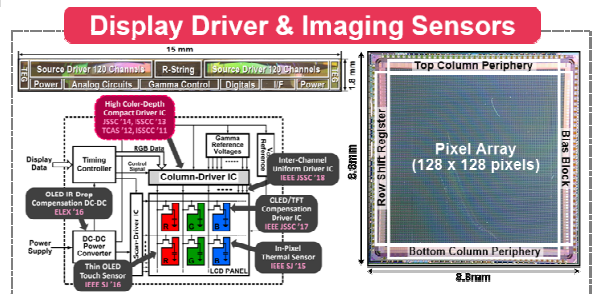
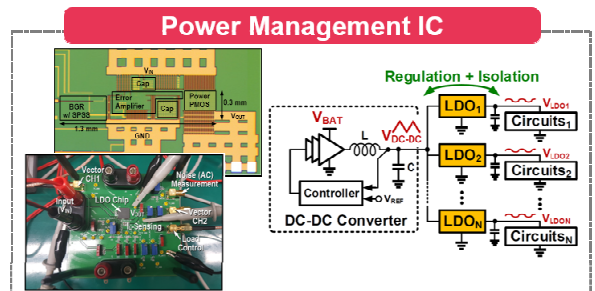
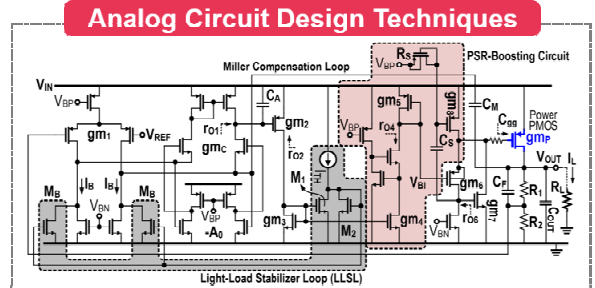

Recommended courses : Circuit Theory, Electronic Circuits, Analog Electronic Circuits, Analog Integrated Circuits, Power Electronics, Digital Circuits

Careers after graduation : Samsung, LG, SK-Hynix, National Research Laboratory, Silicon-Valley, Academia

Introduction to our laboratory

Young and active research environments, Horizontal peer relationship, 24-hours academic discussion, Opened and wide opportunities to attend international conference, Summer/Winter workshop, Refreshed clean office room

Lab. Photo



Recent research achievements ('18~'19)

- "A 300mA BGR-Recursive Low-Dropout Regulator Achieving 102-to-80dB PSR at Frequencies from 100Hz to 0.1MHz with Current Efficiency of 99.98%," *IEEE Symposium on VLSI Circuits (SOVC)*, pp. C132-C133, June 2019.
- "An Active-Matrix OLED Driver CMOS IC with Compensation of Non-Uniform Routing-Line Resistances in Ultra-Thin Panel Bezel," *IEEE Journal of Solid-State Circuits (JSSC)*, vol. 53, no. 2, pp. 484-500, Feb. 2018.



Mixed Signal Integrated Circuits Laboratory

■ Contact information

Professor : EE Building(E3-2) #4225 TEL : 042-350-7425
 Lab. : EE Building(E3-2) #4224, 4230 TEL : 042-350-7525, 7625
 Website : http://msicl.kaist.ac.kr

■ Current state of the Lab. (in 2019 Fall Semester)

Postdoctoral Fellows : 1 PhD Students : 4 Master's Student : 7

■ Research Areas

MSICL researches Analog/Mixed signal circuit design. Major research topic is data converters which converts analog signal to digital signal or vice versa and becomes more important crucial blocks with development of semi-conductor. As digital circuits becomes more popularly used with advanced calculation power and reduced consuming power, analog circuits become essential blocks which transfer the nature signal to digital systems because all the nature signals related to human life are analog signals. Therefore, the research on analog circuits are important with development of circuit systems. However, the number of analog circuit designer is insufficient compared to analog circuit demands.

Besides, MSICL researches readout circuits for various applications. For example, we have dealt with several readout circuits for PC-RAM which is one of the next generation Memory, bio sensor for health care and CMOS image sensors.

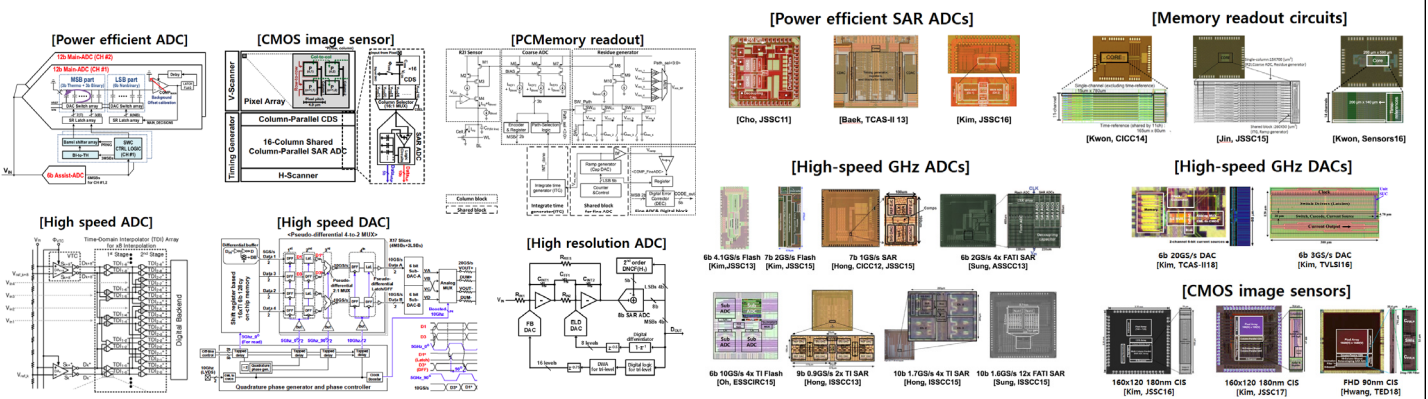

< Various IC Design of MSICL >

< Chip Photographs of MSICL >

■ Recommended courses & Career after graduation

The recommended courses are Electronic Circuits (EE304), Digital Electronic Circuits (EE372), and Analog Electronic Circuits (EE403). The research of MSICL deals with both analog circuits and digital circuits. After graduation, It is possible to create venture company or enter the company/researching-institute related to semi-conductor design.

■ Introduction to other activities besides research

In order to encourage the friendship of group members, many events are held in each seasons. On spring and fall, the members go hiking. On summer and winter, periodic workshop are held. Also, birthday party of each members and midnight snacks are provided.



VLSI 2017 (Kyoto, Japan)

■ Introduction to the Lab.

As mentioned in others sections of this slide, MSICL researches on Analog/Mixed signal circuit design. Data converters which is major topic of our Lab becomes more important in IC system and undergoes lack of the manpower. Since our circuit design treats both analog and digital circuits, the students who have interests in circuit design can get a good chance to study IC circuits. Also, MSICL performs the many projects with companies and researching institute such as Samsung, Hynix, ETRI and so on. So the students can improves the executive ability as well.

■ Recent research achievements ('17~'19)

• Conference / Journal

- [1] Il-Hoon Jang "A 4.2mW 10MHz BW 74.4dB SNDR Fourth-order CT DSM with Second-order Digital Noise Coupling Utilizing an 8b SAR ADC" VLSI 2017.
- [2] Kyoung-Jun Moon, "A 9.1 ENOB 21.7fJ/conversion-step 10b 500MS/s Single-channel Pipelined SAR ADC with a Current-mode Fine ADC in 28nm CMOS" VLSI 2017.
- [3] Dong-Ryeol Oh, "A 65-nm CMOS 6-bit 2.5-GS/s 7.5-mW 8x Time-Domain Interpolating Flash ADC with Sequential Slope-Matching Offset Calibration" JSSC 2018.
- [4] Min-Jae Seo, "A 18.5nW 12-bit 1-ks/s Reset-energy Saving SAR ADC for Bio-Signal Acquisition in 0.18um CMOS " TCAS-1 2018.
- [5] Hyun-Wook Kang, "A Time-Interleaved 12-b 270-MS/s SAR ADC With Virtual-Timing-Reference Timing-Skew Calibration Scheme" JSSC 2018.
- [6] Sun-Il Hwang, "A 2.7-M Pixels 64-mW CMOS Image Sensor With MultiColumn-Parallel Noise-Shaping SAR ADCs" TED 2018.
- [7] Dong-Hwan Jin, "A Reference-Free Temperature-Dependency-Compensating Readout Scheme for Phase-Change Memory Using Flash-ADC-Configured Sense Amplifiers" JSSC 2019.
- [8] Woo-Cheol Kim, "A 6b 28GS/s 4-channel Time-Interleaved Current-Steering DAC with Background Clock Phase Calibration" VLSI 2019.
- [9] Min-Jae Seo, "A 40nm CMOS 12b 200MS/s Single-Amplifier Dual-Residue Pipelined-SAR ADC" VLSI 2019.

| | |
|--|---|
|  <p>Intelligence Computing Systems Laboratory</p> | <p>■ Contact information</p> <p>Professor : Nano Fab Center No. 320 TEL : 042-350-3461 Lab. : Nano Fab Center No. 316 TEL : 042-350-9884 Website : http://ics.kaist.ac.kr/</p> |
| <p>■ Current state of the Lab. (in 2019 Fall Semester)</p> <p>Postdoctoral Fellows : 0 PhD Students: 2 Master's Student: 9</p> | |
| <p>■ Research Areas</p> <p>Intelligence Computing Systems Laboratory (ICSL) was established in 2000 by Professor In-Cheol Park. The research focus of ICSL is on computer architecture, embedded processors, and VLSI architectures for computationally intensive function blocks, such as multimedia signal processing and communication system. The current research scope of the members of ICSL is VLSI designs for error correcting code blocks, deep neural network, and communication systems.</p> <ul style="list-style-type: none"> • Design of microprocessors: Many kinds of processors have been developed such as single-chip programmable SoC platform, and multithread embedded processor. A SoC platform based on 32-bit embedded processor and on-chip bus has been developed together with its corresponding development environment. • VLSI design for error-correcting codes: Error correction is one of the most important techniques used in communication and storage systems to recover messages corrupted in noisy environments. In addition, a low-power LDPC decoder optimized for NAND flash is devised. Also, a multi-rate turbo decoder for mobile communication standards such as 3GPP LTE and LTE-Advanced is developed to achieve near-optimal error-correcting performance. • VLSI design for neural network: The designed neural network accelerator is proposed to achieve high energy efficiency while supporting the scalable structure, which can compute a neural network algorithm in multiple processors.  | |
| <p>■ Recommended courses & Career after graduation</p> <p>'Digital system design', 'Digital signal processing', 'Signals and systems', 'Introduction to computer architecture', and 'Electronic circuits' are recommended as prerequisite courses. Most graduates are employed as professors or as researchers in major companies or national research centers.</p> | <p>■ Introduction to other activities besides research</p> <p>Our laboratory members enjoy out-of-study activities including futsal, basketball and catch. We sometimes go out for movies. Some members also play the piano or guitars in our resting place.</p> |
| <p>■ Introduction to the Lab.</p> <p>ICSL provides one personal PC (Intel Core i7 3.6GHz, 16GB RAM), two FULL HD IPS monitors, 1TB HDD, and 256GB SSD per person, the best research environment in KAIST. We have one project and one research meetings every week, which provide proper guidance for works and researches. Our research topics focus on everything related to VLSI architectures including communications systems, storage systems, neural network and error-correction codes.</p> | |
| <p>■ Recent research achievements ('17~'19)</p> <p>[1] Seokha Hwang, Seungsik Moon, Jaehwan Jung, Daesung Kim, In-Cheol Park, Jeongseok Ha, and Youngjoo Lee, "Energy-efficient Symmetric BC-BCH Decoder Architecture for Mobile Storages," IEEE Transactions on Circuits and Systems-I: Regular Papers, accepted for publication.</p> <p>[2] Byeong Yong Kong and In-Cheol Park, "A 120-mW 0.16-ms-Latency Connectivity-Scalable Multiuser Detector for Interleave Division Multiple Access," IEEE Transactions on Circuits and Systems-II: Express Briefs, accepted for publication.</p> <p>[3] Jihyuck Jo, Soyounng Cha, Dayoung Rho and In-Cheol Park, "DSIP: A Scalable Inference Accelerator for Convolutional Neural Networks," IEEE Journal of Solid-State Circuits, vol. 53, no. 2, pp. 605-618, Feb. 2018.</p> | |

| | |
|--|--|
|  | <p>■ Contact information</p> <p>Professor : Hyeon-Min Bae TEL : 042-350-3489</p> <p>Lab : #307 Nanofab center(E19) TEL : 042-350-5489</p> <p>Website : nais.kaist.ac.kr FAX : 042-350-8089</p> |
| <p>■ Current state of the Lab. (in 2018 Fall Semester)</p> <p>Postdoctoral Fellows : 2 PhD Students: 10 Master's Student: 6</p> | |
| <p>■ Research Areas</p> <div style="display: flex; justify-content: space-between;"> <div style="width: 30%;"> <p>High Speed Serial Interface IC</p>  </div> <div style="width: 30%;"> <p>E-tube</p>  </div> <div style="width: 30%;">    </div> </div> <div style="display: flex; justify-content: space-between; margin-top: 10px;"> <div style="width: 30%;"> <p>fNIRs System</p>  </div> <div style="width: 30%;"> <p>Ultrasound</p>  </div> <div style="width: 30%;"> <p>Bat-inspired Imaging System</p>  </div> </div> | |
| <p>■ Introduction to the Lab.</p> <p>At NAIS lab, we engage in a wide range of research regarding various application fields based on high-speed communication integration circuit technology. As the research topics take system-wide approach, students will be able to experience and accumulate broad spectrum of knowledge during the process of completing the research. The objective of all research performed at NAIS lab is to implement and commercialize innovative systems through disruptive technology. NAIS lab encourages students to experience venture ecosystem by getting involved in establishing ventures based on the research performed during the graduate school years. OBELAB and Terasquare are the two venture start-ups that were established, based on the research conducted during the graduate school years at NAIS lab.</p> | |
| <p>■ Recommended courses & Career after graduation</p> <p>One of the most important virtue at NAIS lab is 'craftsmanship'. For this, NAIS lab focuses on research and development involving communication circuits, and it is recommended that students take courses in circuit, digital, and communication-related subjects.</p> <p>Graduates of NAIS lab pursue careers both in industry and academia. They seek to enhance the degree of completion of their own research carried out at NAIS lab.</p> | <p>■ About NAIS lab</p> <p>NAIS lab was established in 2009. It is constantly challenging and pursuing progress in many areas of research. The doctorate and the masters degree students are working in a friendly atmosphere. Students enjoy athletic activities and other hobbies. The lively atmosphere of the lab makes it possible for the students to devote themselves to research and to enjoy school life.</p> |
| <p>■ Recent research achievements ('17~'19) : International Journal 21, International Conference 23, Patent 40</p> <p>[1] Jaehyeok Yang, Seohyeon Kim, Gunpil Hwang, Kyeongha Kwon, Sejun Jeon, Hyeon-Min Bae, "Reference-Less Time-Division Duplex Transceiver IC for a Renal Denervation System", IEEE Journal of Solid-State Circuits (JSSC), no. 6, pp. 1657-1668, June 2019.</p> <p>[2] Kyeongha Kwon, Jong-Hyeok Yoon, Younho Jeon, Hanho Choi, Sejun Jeon, Hyeon-Min Bae, "An Electronic Dispersion Compensation Transceiver for 10-Gb/s and 28-Gb/s Directly Modulated Lasers-Based Optical Link", IEEE Journal of Solid-State Circuits (JSSC), no. 1, vol. 54, Jan. 2019.</p> <p>[3] Jaemyoung Kim, Jongkwan Choi, Mingyu Choi, Minsu Ji, Gunpil Hwang, Sang-Bae Ko, Hyeon-Min Bae, "Assessment of cerebral autoregulation using continuous-wave near-infrared spectroscopy during squat-stand maneuvers in subjects with symptoms of orthostatic intolerance", Scientific Reports, no. 8, Sept. 2018.</p> | |

μComputing Lab

Korea Advanced Institute of Science and Technology

Contact information

Professor: S-207, NanoFab Center (E19) TEL: 82-42-350-3479
 Lab.: S-204, NanoFab Center (E19) TEL: 82-42-350-5479
 Website: <http://dtlab.kaist.ac.kr>

Current state of the Lab. (in Fall Semester 2019)

PhD Students: 3 Master Students: 6

Research Areas

Computer-Aided Design (CAD), Electronic Design Automation (EDA), Design Technology & Innovation

Our research encompasses various aspects of VLSI Computer-Aided Design (CAD).

Detailed research area includes logic synthesis considering clock gating, timing analysis, power analysis and optimization (high-level power modeling, leakage minimization), Lithography optimization (optical proximity correction, pattern classification & synthesis, lithography modeling, assist feature insertion). Especially, We are studying the method to graft machine learning algorithm onto various CAD topics.

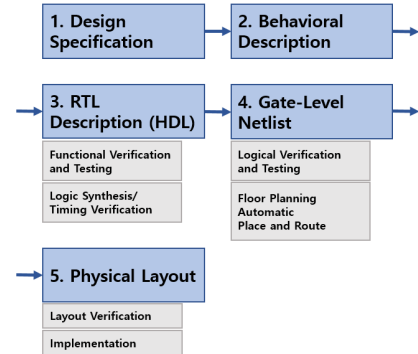

Clock Tree Power Analysis

In most of chips, clock tree consumes significant amount of power. However, clock network structure is unknown during most design stages because clock tree synthesis (CTS) is usually performed in a late stage of physical design. Our research presented a machine learning-based method to estimate the transient clock power from pre-CTS (Clock Tree Synthesis) gate-level netlist. Estimated clock tree power showed the error of 2% on average. Moreover, we are trying to predict structure of clock tree network by taking advantage of machine learning.

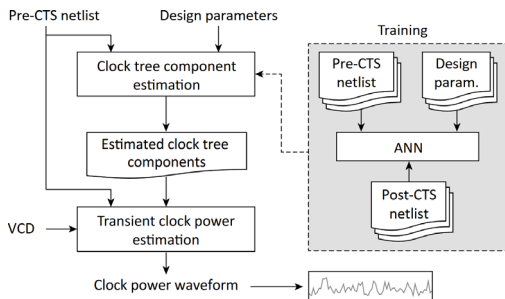

Computational Lithography

It is essential to improve the resolution of lithography process to develop new generation of technology node. Computational lithography is a set of algorithmic approach to enhance the resolution. Corresponding processes take more than 7 days to operate the algorithm. We are currently studying how to apply machine learning in order to make the faster and more accurate methods

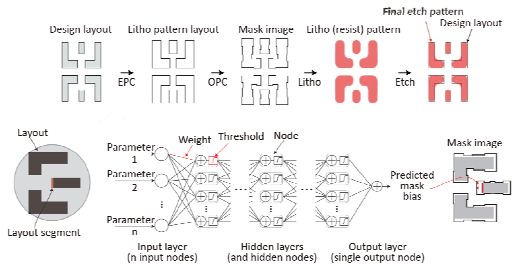

Layout Synthesis using GAN

In this research area, we propose the method to synthesize test layout patterns using machine learning. Since Layout can be expressed in discrete cosine transform signals, we can generate DCT signals corresponding effective layout by applying generative adversarial network (GAN). Proposed method showed the edge proximity error of 20%, on average.

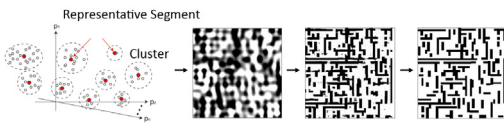

Recommended courses & Career after graduation

- Digital System (EE303) for undergraduate students
 - CAD for VLSI (EE574) and Digital Integrated Circuit (EE678) for graduate students
 - Research programs (e.g. URP) are highly recommended.
- Most alumni entered leading semiconductor (IBM, NVIDIA, Samsung Electronics, SK Hynix, and LG Electronics) and EDA companies (Synopsys, Cadence).

Introduction to other activities besides research







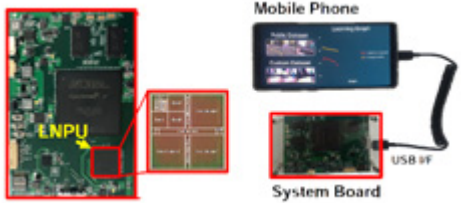
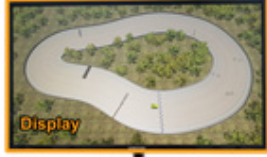

- Monthly social gathering; graduation and birthday celebrations
- Sports activities: football, table tennis, and basketball
- Internship opportunities in IBM, Synopsys, Cadence (USA), and IMEC (Belgium)
 - During 2016, two PhD students visited IBM for 6 months; and one MS student visited IMEC for 3 months.
 - During 2019, one PhD student visited Synopsys for 4 months.

Introduction to the Lab.

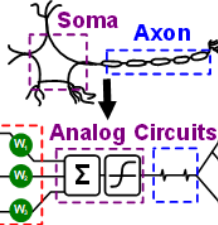
We all pursue excellent achievement in family-like atmosphere. We have regular working time and stable fund. Prof. Shin always welcomes personal meeting for detailed discussion on research topic, and he enthusiastically supports and motivates students.

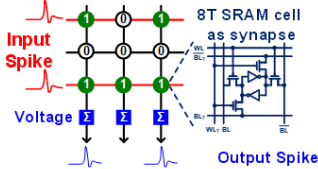
Recent research achievements ('16~'19)

- Consistent publications on top-class international journals (e.g. IEEE TCAD) and international conferences (e.g. DAC, ICCAD).
- Prof. Shin has been elevated to IEEE Fellow on 2017; Prof. Shin has lead international conference ASP-DAC 2018 as a General Chair.
- Our lab member has received "Outstanding Ph. D. Dissertation Award," which is for the best alumni in our school per year.

| | |
|--|--|
|  <p>Semiconductor System Laboratory</p> | <p>■ Contact information</p> <p>Professor : E3-2 #1221 TEL : 042-350-3468 Lab. : E3-2 #1233 TEL : 042-350-8068 Website : http://ssl.kaist.ac.kr</p> |
| <p>■ Current state of the Lab.</p> <p>Postdoctoral Fellows : 3 PhD Students: 12 Master's Student: 8</p> | |
| <p>■ Research Areas</p> <p>Humanistic Intelligence System</p> <ul style="list-style-type: none"> - General Purpose Mobile DRL Processor with Adaptive Data Reuse - Sparse High DNN Learning Processor with Fine-grained Mixed Precision - CNN-RNN Unified Energy-efficient Mobile DNN Accelerator - CNN Super Resolution Processor for Full HD 60fps Video - Energy Efficient DNN Learning Processor with Direct Feedback Alignment <p>Neuromorphic</p> <ul style="list-style-type: none"> - High Efficiency Analog-Digital Hybrid Computing Architecture - PIM (Processing-in Memory) - Biological Neural Network System - Biologically Plausible Learning Algorithms based System |       |
| <p>■ Recommended courses & Career after graduation</p> <ul style="list-style-type: none"> - Circuit related courses (analog & digital), computer architecture, and digital systems will help. But, you will learn everything you need through lab seminar. - Companies & research institutes all over the world (Samsung, LG, Apple, IBM, IMEC, etc.) | <p>■ Introduction to other activities besides research</p> <p>In SSL, you will get a chance to explore international companies and research facilities like Samsung, IMEC, IME, Apple every year. Moreover, joint workshop with chinese and japanese university is held every year. There are also lab workshops and parties with lab members.</p> |
| <p>■ Introduction to the Lab.</p> <ul style="list-style-type: none"> • Privilege of SSL Members - Pride from world leading researches - Business trip abroad average of 2 times per year - Accepted to various international conferences/journals - Project leading skills, and presentation skills - Chip with your name inscribed on <ul style="list-style-type: none"> • SSL Wanted - Who has passion to be the best - Who want to become a world leading engineer <p>• Statue of SSL → You can feel it through your skin at international conferences</p> | |
| <p>■ Recent research achievements('16~'19)</p> <p>[1] Presenting at Top Class International Conferences Every Year (ISSCC 2019 Plenary Talk, ISSCC 2019 5 Paper, HOTCHIPS 2019 1 Paper, S. VLSI 2019 2 Paper, CICC 2019 2 Paper) [2] 2016~19년 International Conferences 46 Paper, International Journal 28 Paper [3] International Joint Workshop (Tsignhua Univ. in China, Tokyo Univ. in Japan) [4] ISSCC 18 Demo. Award (Jinmook Lee), ISSCC 18 Demo. Award (Sungpill Choi), AICAS 2019 Best Paper Award</p> <div style="display: flex; justify-content: space-around;"> <div data-bbox="129 1845 443 2063">  <p><ISSCC 2019 Plenary Talk></p> </div> <div data-bbox="459 1845 938 2063">  <p><ISSCC 2018 Demo. Award></p> </div> <div data-bbox="954 1845 1433 2063">  <p><ISSCC 2018 Demo. Award></p> </div> </div> | |

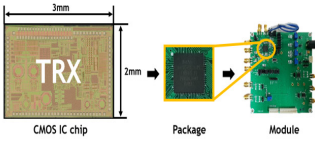
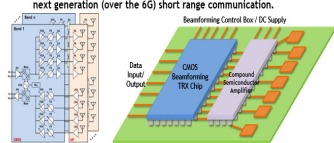
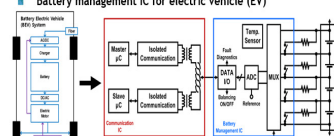
| | |
|--|--|
|  | <p>■ Contact information Professor : Sang-gug Lee TEL : 042-350-3491 Lab. : Electrical Engineering Building (E3-2) #2228 TEL : 042-350-5491 Website : https://nice.kaist.ac.kr</p> |
| <p>■ Current state of the Lab. (in 2019 Fall Semester) Postdoctoral Fellows : 1 PhD Students: 14 PhD and Master Combined Students: 2 Master's Student: 4</p> | |
| <p>■ Research Areas ▶ Ultra-Low Power (ULP) Wireless Communication Transceiver</p> | |
| <p>Wireless communications with minimum power dissipation is under spotlight with growing interest in IoT. For this purpose, NICE lab is actively working on ULP wireless and wake-up transceivers</p> | <p>Nano Integrated Circuit Expertise (NICE) Lab. (Prof. Sang-gug Lee)</p> <div style="display: flex; justify-content: space-around;"> <div data-bbox="770 533 1086 725"> <p>Ultra-Low Power Wireless Transceiver</p> <p>■ μW-class wide area wireless transceivers for IoT applications</p>  </div> <div data-bbox="1102 533 1437 725"> <p>CMOS-based THz 6G Transceiver</p> <p>■ A 200-400GHz multi-channel beamforming wireless transceiver for next generation (over the 6G) short range communication.</p>  </div> </div> |
| <p>▶ THz imaging system and transceiver for 6G communications Our lab is studying imaging systems using sub-terahertz bands and sub-terahertz circuits (PA, LNA, Mixer, VCO etc) that make up wireless transceivers with data rates of over 100Gbps for next-generation 6G communications.</p> | <p>Next Gen. Battery Management Algorithm</p> <p>■ Convergent research for real-time material diagnosis</p>  |
| <p>▶ Battery Management Integrated Circuit (BMIC) Power management systems are being studied, which include a DC-DC converter that automatically changes state depending on the state of the energy harvesting source and the battery</p> <p>▶ Next Generation Battery Management Algorithm Through real-time tracking of thermodynamic state parameter, work on the development of a novel battery management system based on the material and chemical state of the battery for safer and more precise control.</p> | <p>Battery Management IC</p> <p>■ Battery management IC for electric vehicle (EV)</p>  |
| <p>■ Recommended courses & Career after graduation Recommended courses include Analog/RF/Digital Circuits, Communication Theory, Electromagnetics, Microwaves, Physical Electronics, and others as deemed necessary. Graduates can serve in companies, academia, government-funded research centers, and reputable national and international organizations.</p> | <p>■ Introduction to other activities besides research NICE lab conducts homecoming event annually to strengthen the bond between alumni and current students. Moreover, organize biannual workshops as extra-curricular activities. Lab members engage regularly in sports and other occasional meet-ups to ensure a friendly and cheerful environment.</p> |
| <p>■ Introduction to the Lab. Nano-Integrated Circuit Expertise (NICE) Lab provides its members a significant exposure to RF/Analog Circuits and Systems, and CMOS Integrated Circuits. Our expertise include circuits and systems for wireless communication, energy harvesting, imaging, and battery management. Our current research includes ULP long range wireless communication radio, THz Systems, and Battery Management IC and algorithm. Moreover, NICE lab fully supports its members for CMOS IC fabrication.</p> | |
| <p>■ Recent research achievements ('17~'19)</p> <p>[1] S. Shin, D. R. Utomo, H. Jung, Jusung Kim, S.-G. Lee, "Wide Locking-Range Frequency Multiplier by 1.5 Employing Quadrature Injection-Locked Frequency Tripler With Embedded Notch Filtering," IEEE Transactions on Microwave Theory and Techniques, (accepted for publication).</p> <p>[2] D.W. Park, D.R. Utomo, J.P. Hong and S.G. Lee, "A 230–260-GHz Wideband and High-Gain Amplifier in 65-nm CMOS Based on Dual-Peak Gmax-Core," IEEE Journal of Solid-State Circuits, vol. 54, no. 6, 2019</p> <p>[3] B.M. Lim, J.I. Seo, and S.G. Lee, "A Colpitts Oscillator-Based Self-Starting Boost Converter for Thermoelectric Energy Harvesting With 40-mV Startup Voltage and 75% Maximum Efficiency," IEEE Journal of Solid-State Circuits, vol. 53, no. 11, 2018</p> | |

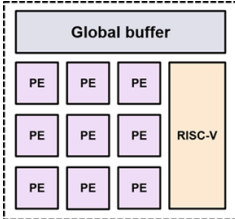
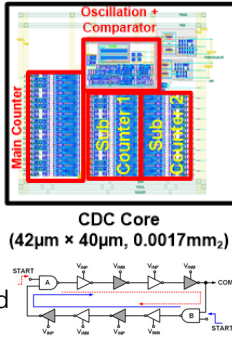
| | |
|--|--|
| <p>Smart Energy-Efficient Design Laboratory</p> | <p> ■ Contact information Professor : wanyeong@kaist.ac.kr TEL : 042-350-7459 Lab. : TBD TEL : 042-350-7559 / 7659 Website : TBD (PI's personal website: http://www.mit.edu/~wanyeong/) </p> |
| <p> ■ Current state of the Lab. (in 2019 Fall Semester) Postdoctoral Fellows : 0 PhD Students: 0 Master's Student: 0 </p> | |
| <p> ■ Research Areas Autonomous Power Management for Self-Powered Devices In a small and remote IoT device, improving efficiency in energy harvesting and power management is essential to extend overall system operating time. The PI has developed several switched-capacitor (SC) DC-DC converters for energy harvesting and power management. He is now exploring broader power management issues including fine-grained DVFS and design automation the whole power delivery network as well as performance optimization along with load circuits. </p>  <p> Machine Learning on Edge Devices Data transfer between remote devices and a base station is costly in terms of both energy and latency, so it is necessary to pre-process collected data before wireless transmission. Machine learning can process various types of data by a single algorithm, which allows us to make a unified data processing accelerator that can be widely used in many device regardless of specific data type. PI has developed a general inference accelerator for various types of CNN networks, and plans to extend his research for better efficiency and versatility. </p>  <p> Energy-Efficient Sensors in Advanced Technologies Sensor interfaces are difficult to scale down because of noise, process variations, and the reduction of output swing and intrinsic gain in advanced processes. The PI tried to modify the topology of conventional analog circuits to look more like digital circuits, so that they fully benefit from process scaling. This scheme can be applied to many different types of sensors and ADCs, and can be easily combined with other digital-oriented techniques. Its simpler and more robust structure brings down the cost for design. </p>  | |
| <p> ■ Recommended courses & Career after graduation Courses for analog or digital integrated circuits are strongly recommended. However, students with other backgrounds such as computer science and engineering, architecture, communication and signal processing are also very welcomed. </p> | <p> ■ Introduction to other activities besides research The lab will hold group dinners and annual workshop. The PI is willing to support other student-driven events and activities. Group members will attend top international conferences in the field of integrated circuits such as ISSCC and VLSI-C. </p> |
| <p> ■ Introduction to the Lab. The PI joined KAIST in August 2019, and now actively hiring graduate students who are interested in IoT / low-power circuits and systems or its applications. </p> | |
| <p> ■ Recent research achievements ('17~'19) [1] "Edge-Pursuit Comparator: An Energy- Scalable Oscillator Collapse-Based Comparator With Application in a 74.1 dB SNDR and 20 kS/s 15b SAR ADC," <i>IEEE JSSC</i> Apr. 2017 (Invited for a special issue) [2] "A Start-up Boosting Circuit with 133x Speed Gain for 2-Transistor Voltage Reference", <i>IEEE CICC</i>, 2017 [3] "A 0.6nJ .022/+0.19°C inaccuracy temperature sensor using exponential subthreshold oscillation dependence", <i>IEEE ISSCC</i>, 2017. </p> | |



Contact information

Professor: National Nano Fab. Center #317 TEL: 7437
 Lab: National Nano Fab. Center #316 TEL: 7637
 Website: <http://impact.kaist.ac.kr/>

Current state of the Lab. (in 2019 Fall Semester)

Postdoctoral Fellows : 1 PhD Students: 22 Master's Student: 10

Research Areas

The core technology of the research is analog, mixed-signal, and RF integrated circuit design techniques, especially focusing on intelligent sensor interface circuits and ultra low power wireless communication circuits.

▷ **Intelligent sensor interface**

The sensor interface circuit that works with the sensor is an essential component to acquire the information of the real physical world. It has to provide sufficient performance while consuming low power. In particular, we aim to develop an intelligent interface circuit that can compensate the deficiencies of the sensor and extract meaningful information even under imperfect conditions.

▷ **Ultra-low-power wireless communication**

Particularly, we are interested in the technology that realizes the short distance communication in the vicinity of the human body with high energy efficiency as well as the various circuit techniques for duty-cycling the wireless communication circuits which consume the most power in the wireless sensor microsystems as much as possible.

▷ **Microsystem convergence for emerging applications**

Based on this low-power integrated circuit technology, the extremely small and intelligent systems can be integrated for various applications expected to play an important role in the future. Especially, the miniaturized medical device that can be implanted inside a human body for therapeutics, brain research, and neuromodulation is the main application area. We are also interested in wearable devices which are expected to be the next generation mobile devices, and ultra low power wireless sensor nodes which are key to the implementation of the internet of things.

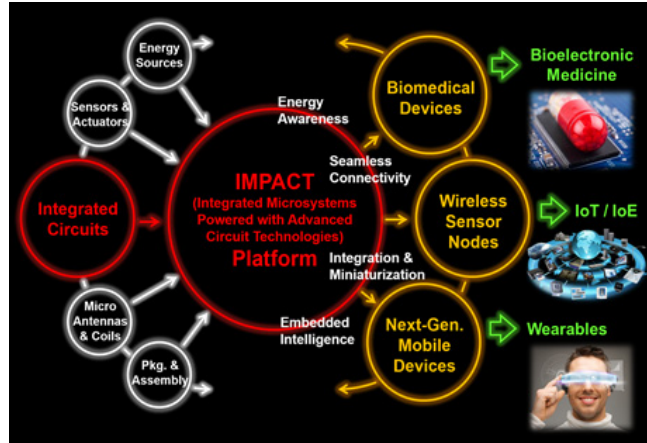

Recommended courses & Career after graduation

Courses on circuit and system design as well as wireless communication are recommended, which include circuit theory, electronic circuits, analog electronic circuits, digital electronic circuits, digital systems, digital signal processing, communication engineering, and radio engineering. After graduation, your career can be furthered at a variety of domestic and foreign companies, research institutes, or universities related to integrated circuit and microsystem design as well as research and development in the application areas of IoT, wearables, and medical devices.

Introduction to other activities besides research

The IMPACT lab. is fairly new in that we started just two years ago at KAIST. Therefore, the members can make an important contribution in forming the culture of the laboratory. The best possible support will be provided to create an environment in which the members can engage in research with pleasant passion, voluntary commitment, and open exchange, based on strong mutual trust. A variety of non-research activities are also being created in line with this.

Introduction to the Lab.

We are not just targeting to develop new circuit design techniques, but to create substantial achievement that can greatly affect our future lives, by working together with experts from diverse fields including sensor, energy, communication, packaging, as well as medical devices and IT applications through an international collaborative research network.

Recent research achievements ('18~'19)

- [1] "A Multimodal Multichannel Neural Activity Readout IC with 0.7μW/Channel Ca²⁺-Probe-Based Fluorescence Recording and Electrical Recording," SOVC 2019
- [2] "A 100Mb/s Galvanically-Coupled Body-Channel-Communication Transceiver with 4.75 pJ/b TX and 26.8 pJ/b RX for Bionic Arms," SOVC 2019
- [3] "A 110dB-CMRR 100dB-PSRR Multi-Channel Neural Recording Amplifier System Using Differentially Regulated Rejection Ratio Enhancement in 0.18μm CMOS," IEEE ISSCC 2018
- [4] "A 6.5W 92.3dB-DR Biopotential Recording Front-End with 360mVpp Linear Input Range," SOVC 2018
- [5] "A 114-aFrms-Resolution 46-nF/10-M-Range Digital-Intensive Reconfigurable RC-to-Digital Converter," SOVC 2018

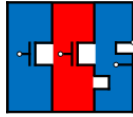

Cho's Circuits and Systems Laboratory (CCSLAB)

Contact information

Professor : Nano-Fab Center 308 TEL : 042-350-3480
 Lab. : Nano-Fab Center 304 TEL : 042-351-9932
 Website : <http://ccs.kaist.ac.kr/>

Current state of the Lab. (in 2019 Fall Semester)

Ph. D. Students: 10 Master's Degree Students: 6

Research Areas

▷ High Speed Analog Circuits

The high speed analog circuits studied in our laboratory include clock generation, memory interface, and wireline transceiver. Representively, PLL is an essential analog and mixed-mode circuit which synthesizes system clock to the desired frequency for communication system. Recently, we are focusing on V-band(40-75GHz) and W-band(75-110GHz) PLLs for RADAR applications.

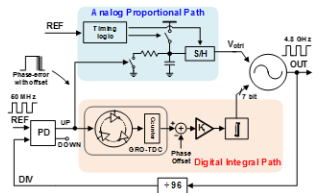

▷ Sensors

High-performance biomedical and environmental sensors are our research interests. Sensors should be low-power and high-fidelity for wearable and IoT applications. In bio-sensor team, ECG Analog-Front-End and BCC TRX are studied, and in environmental sensor team, accelerometer and humidity sensors in CMOS process.

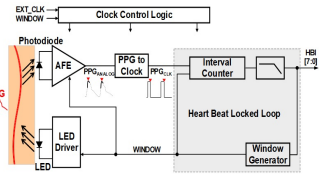

▷ Machine Learning Processors

Machine learning based on neural network has garnered great interest over the past decade as it has the potential to revolutionize various technologies for commercial and industrial use. In particular, we are interested to implement machine learning processor in analog circuit domain which is effective to achieve low-power and high-speed operation than digital domain.

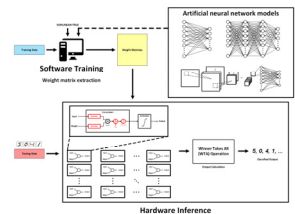

Recommended courses & Career after graduation

Students are encouraged to take Circuit Theory, Electronic Circuits, Communication System, Introduction to Physical Electronics and Digital Signal Processing. Alumni are working with international major companies and research institutes such as DGIST, ETH Zurich, KAIST (Faculty), NVidia, Qualcomm, Broadcom, A*STAR, Samsung Electronics, Fairchild, MIT, Stanford, Univ. of Michigan, U. C. San Diego, MIT Sloan (MBA), and T. U. Delft.

Introduction to other activities besides research

We take annual/seasonal events such as strawberry party (spring season), ski camp and workshop to foster friendship. Also, members can have flexible vacation plan during the year to refresh and reinforce their motivation. We offer various opportunities to participate in international conferences.



Introduction to the Lab.

Our group explores emerging technologies for high-performance communication and bio-medical/environment sensors. Research focus is on the design of analog integrated circuits with multiple layers of system abstraction in mind, from algorithms and system architectures to circuit techniques and devices. Our main research area is analog interface for medical and CMOS sensors, phase-locked loops (PLL), analog-to-digital converters (ADCs). Recently we are also looking into efficient circuits for machine learning as well as health care using wearable devices.

Recent research achievements ('17~'19)

[1] S. Park, G-H. Lee, and S.H. Cho, "A 2.92- μ W Capacitance-to-Digital Converter With Differential Bondwire Accelerometer, On-Chip Air Pressure, and Humidity Sensor in 0.18- μ m CMOS," IEEE J. Solid-State Circuits, Early Access, 2019.
 [2] J. Lee, G-H. Lee, H. Kim, and S.H. Cho, "An Ultra-high Input Impedance Analog Front-end with Self-calibrated Positive Feedback," IEEE J. Solid-State Circuits, vol. 53, no. 8, 2018.
 [3] N. Koo, S.H. Cho, "A 27.8 μ W Biopotential Amplifier Tolerant to 30VPP Common-Mode Interference for Two-Electrode ECG Recording in 0.18 μ m CMOS," IEEE Int'l Solid-State Circuits Conference (ISSCC), 2019
 [4] D. Jang, S. H. Cho, "A 43.4 μ W photoplethysmogram-based heart-rate sensor using heart-beat-locked loop," IEEE Int'l Solid-State Circuits Conference (ISSCC), 2018.

| | | | |
|--|--|--|--|
| | | ■ Contact information Professor : Jaehyouk Choi TEL : 042-350-7458 Lab. : ICSL TEL : 042-350-7558 Website : icsl.kaist.ac.kr | |
| ■ Current state of the Lab. (in 2019 Fall Semester) Postdoctoral Fellows : 0 PhD Students: 8 Master's Student: 5 | | | |
| ■ Research Areas High-performance wireless transceivers for mm-W-band 5G and beyond-5G systems Wireless transceiver ICs for cellular communications that can support ultra-wideband data communications in the millimeter high-frequency band are the core of 5G system. Since 5G systems are being commercialized based on "interoperability" with 4G LTE, it is essential for 5G chips to simultaneously support existing bands as well as new millimeter bands. This study aims to research and develop 5G cellular communication ICs that can obtain unique global market competitiveness. Based on the technology acquired in 5G research, we plan to study Beyond 5G and 6G over the next 10 years. It is expected that 6G will require 10 times more communication speed than 5G communication. Subsequent research is being conducted on new integrated circuit technologies that enable the generation and communication of signals in frequency bands above 100 GHz using Silicon devices. | | | |
| Ultra-low-jitter high-frequency clock generation and distribution for high-performance SoC and memory Among oscillator structures that are the core circuits of high frequency signal generators, ring oscillators have a high degree of integration, so it is suitable for use in SoC and memory systems where density is important, but noise performance, which is significantly inferior to the LC structure, has been a problem. So, it has been impossible for ring oscillators to be used in 5G communication and SerDes system requiring ultra-low jitter. The LC structure, on the other hand, has excellent jitter performance but has a problem of occupying a large silicon area. Increasingly the range of clock signals required by semiconductor systems, the use of multiple LC oscillators leads to significant increases in silicon area and manufacturing costs. This study aims to study the ultra-miniature, ultra-low noise signal generators that can fundamentally overcome the dilemma between ring and LC oscillators. | | | |
| Self-sustaining multi-purpose environment IoT platforms The ultimate future for IoT is a hyper-connected world where various sensors are widely deployed in nature or the surrounding environment, and many of these sensors collect, process and deliver small pieces of information that are easy to miss. In particular, the role of environmental IoT sensors is very important, since they can be used to continuously monitor inaccessible environments and predict risks early to prevent disasters. The key to future IoT sensor technology is self-powering. Thus, the key is to design ultra-low-power circuits that collect energy from various environmental elements, manage power and batteries based on them, and measure, collect, and transmit target signals. This study aims to develop a self-powered multi-mode environment IoT sensor platform. | | | |
| ■ Career after graduation IC designer in global companies Researcher in international research institutes Instructor in universities | | ■ Introduction to other activities besides research Group sports (Basketball, badminton...) Movie night/ Team trip Global company internship (Qualcomm, Intel, etc) Participation in international conferences (ISSCC, VLSI-Symp.) | |
| ■ Introduction to the Lab. ICSL is the group pursuing the world-class research in analog, mixed, and RFIC fields in a family-like atmosphere. We research together, study together, play together, thereby growing together as a researcher equipped with both research ability and sociability. | | | |
| ■ Recent research achievements ('17~'19) "A 76fs _{RMS} -jitterand-40dBc-integrated-phase-noise 28-31GHz frequency synthesizer based on digital sub-sampling PLL using optimally-spaced voltage comparators and background loop-gain optimization," <i>ISSCC 2019</i> , February 2019 "A 140fs _{RMS} -jitterand-72dBc-reference-spur ring-VCO-based injection-locked clock multiplier using a background triple-point frequency/phase/slope calibrator," <i>ISSCC 2019</i> , February 2019. "A 0.5V-V _{IN} ,0.29ps-Transient-FOM, and Sub-2mV-Accuracy Adaptive-Sampling Digital LDO Using Single- VCO-Based Edge-RacingTime Quantizer", <i>VLSI Symposium 2019</i> , June 2019. "A -31dBc integrated-phase-noise 29GHz fractional-N frequency synthesizer supporting multiple frequency bands for backward-compatible 5G," <i>ISSCC 2018</i> , February 2018. "Self-sustaining water-motion sensor platform for continuous monitoring of frequency and amplitude dynamics," <i>Nano Energy (Elsevier) (IF = 12.343)</i> , May 2017. | | | |

Communication Division



| | |
|---|--|
|  <p>Advanced Radio Technology Laboratory</p> | <p>■ Contact information Professor : ITC bldg. (N1), #714 TEL : +82-42-350-7422 Lab. : ITC bldg. (N1), #719 TEL : +82-42-350-7522 Website : http://artlab.kaist.ac.kr</p> |
| <p>■ Current state of the Lab. (in 2019 Fall Semester) Postdoctoral Fellows : 1 PhD Students: 11 Master's Student: 5</p> | |
| <p>■ Research Areas</p> <p>The Advanced Radio Technology Laboratory (ART Lab) has researched the signal processing technology used in communication systems and various related technologies. In particular, to improve the reliability, transmission rate and spectral efficiency of wireless communication, we focused on multi-input multi-output (MIMO), massive MIMO, cognitive radio and etc. Furthermore, GPS-free localization and security issues at the physical layer are important parts of our research area. We also research innovative technologies to be used in the 5G wireless communication system. including artificial intelligence (AI). Specific research topics are given as follows.</p> <ul style="list-style-type: none"> - Multiple-input Multiple-output (MIMO) and Massive MIMO MIMO uses multiple antennas for base stations and mobile users to increase the data rate and reliability. The technique of using a large number of antennas in MIMO is called Massive MIMO. Recently, ART Lab has been working on energy efficient problems in Massive MIMO. Also, we investigate problems related to interference control, resource allocation, user scheduling and etc. - Cognitive Radio (CR) The CR is a representative technique that secondary user recognizes the wireless communication environment and communicates opportunistically. Therefore, It is important to optimize and allocate the available radio frequency while minimizing interference to primary user. So, ART Lab is researching a spectrum sensing technique and allocating the resources for improving a user's transmission rate and spectral efficiency in CR network. - Localization Localization is a technique for estimating the position of a mobile user. The ART Lab develops localization techniques for indoor and wartime conditions without using GPS. A localization algorithm with low complexity and high accuracy is also being researched. - 5G Communication System In recent years, ART Lab has been researching full-duplex, cloud radio access network (C-RAN), mmWave system, and machine learning for the 5G communication system. | |
| <p>■ Recommended courses & Career after graduation</p> <ul style="list-style-type: none"> - Recommended courses : Signal and systems, Probability and statistics, communication engineering, Linear algebra - Career after graduation : Many promising graduated students in ART LAB currently work in the various field: Professor at university, a research institute (Agency for Defense Development (ADD) and Electronics and Telecommunications Research Institute (ETRI)), and major company (Samsung Electronics Co. KT Co. and etc.) | <p>■ Introduction to other activities besides research</p> <p>ART lab promotes friendship among the students with various activities: birthday party, summer/winter workshop, picnics and so on. We frequently play sports such as soccer and basketball together to refresh our mind and body. Also, we have homecoming day annually and share alumni's experience for setting a goal and choosing a job after their graduation.</p> |
| <p>■ Introduction to the Lab.</p> <p>All students in ART lab endeavor to be a leader in signal processing and wireless communication. So, our laboratory encourages students to research in an environment where members feel free to share their ideas. We have considerate professor's guidance and promote active cooperation among members. Also, by doing sports and many other events, we can spend our time in graduate school energetically. ART lab is open to who wants to research and study in a good environment with prospective students.</p> | |
| <p>■ Recent research achievements ('17~'19)</p> <p>[1] Projects : ETRI, ADD, Samsung Electronics Co., Ministry of Science, ICT and Future Planning, etc. (Currently doing eight projects)</p> <p>[2] publications : Journal papers 17 / Conference papers 11 / Patents 15</p> | |

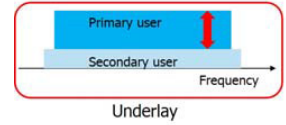
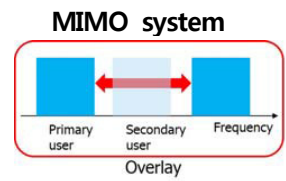
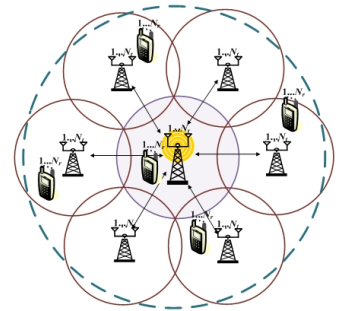

Cognitive radio

MoonLab

Storage, Communications & Machine Learning

Contact information

Professor : N1 bldg. Room #616 TEL : 042-350-3487
 Lab. : N1 bldg. Room #617 TEL : 042-350-5487, 8087
 Website : <http://comstolab.kaist.ac.kr>

Current state of the Lab. (in 2019 Fall Semester)

Postdoctoral Fellows: 1 PhD Students: 7 Master's Students: 5

Research Areas

We work on distributed and decentralized forms of machine learning, storage and communications, dealing with optimal ways to store, access and process big data in today's densely connected world. Distributed and decentralized ways of data storage and machine learning are essential in the era of IoT, big data and connected AI.

Distributed Storage and Blockchain

With the advent of Big Data era, how to manage and process these data is one of the crucial issues in various applications. In order to protect data against possible local failures and hacker attacks and to maximally utilize available storage spaces, data is stored over a distributed network. We focus on important issues in distributed storage including download speed, repair speed given local failures, storage space efficiency, privacy guarantee and ability to withstand hacker attacks. Blockchain is another peer to peer distributed ledger technology, which enables decentralization without any trusted central authorities. We also focus on applying coding and information theory to blockchain to enhance performance for practical usage.

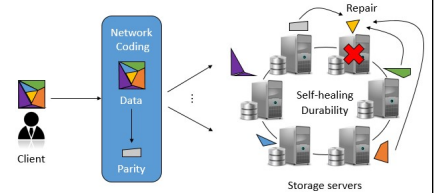

Fig.1 Distributed Storage System

Artificial Intelligence (Meta Learning, Multi-modal Learning)

Machine learning is a data processing where necessary information gets extracted from massive data using modern learning methods, which is a key technology for intelligent systems like the self-driving car and smart factory. Moon Lab focuses on developing neural network architecture and learning algorithm for high speed/adaptive meta learning. We also focus on developing hardware-friendly learning algorithms for efficient machine learning on edge devices. Moreover, we investigate the multi-modal learning algorithms for autonomous driving system based on the clustered structure of neural network and information exchange modules.

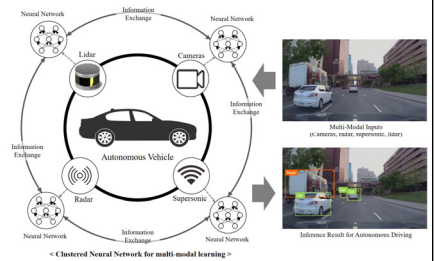

Fig.2 Multi-modal Learning

Distributed Machine Learning

Distributed machine learning enables to train a large-scale learning model with massive dataset. We investigate ways of speeding up distributed learning in various scenarios. We propose hierarchical broadcast coding, a coding technique highly tailored to the practical environments of the wireless edge with overlapped/broadcast nodes. We also propose election coding, which is a coding framework for protecting a communication-efficient distributed learning algorithm (called SignSGD with majority vote) against Byzantine attacks. This framework explores new information-theoretic limits of finding the majority opinion when some workers could be malicious, and paves the road to implement robust and efficient distributed learning algorithms.

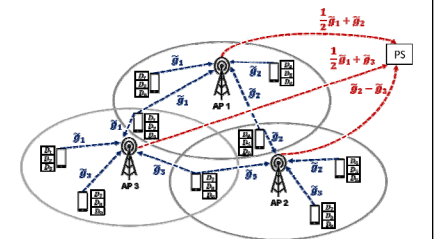

Fig. 3 Distributed Learning

System Error-Correction Codes / NAND Flash

Interference between adjacent data cells becomes severe as the density of storage devices increases. Under this scenario, we study error-correction codes with a particular focus on the tradeoffs and efficient allocation of resources throughout the system. We also investigate equalization and error-correction codes to reduce the error rate of 3D NAND flash.

Recommended courses & Career after graduation

Classes that strengthen backgrounds on mathematics and probabilities/statistics are desired. Graduates pursue career in research and R&D at numerous domestic and overseas companies and universities.

Introduction to other activities besides research

Horizontal, non-hierarchical relationships are valued among lab members. Strong emphasis is placed on quality of life. Environments are maintained where free discussions and stimulating interactions are encouraged. Regular meals, picnics and MTs with all members participating add spices to life at Moon Lab.



Introduction to the Lab.

Moon Lab pursues math-oriented research but also seeks to have impacts on applications. Students choose topics after much discussions with Professor and may also change the course of research along the way.

Recent research achievements ('17~'19) : 24 Publications (11 Journals and 13 Conference Papers)

Selected Journals and Conference Papers



- [1] J. Sohn, B. Choi, S. W. Yoon and J. Moon, "Capacity of Clustered Distributed Storage," IEEE Transactions on Information Theory, 2019. (conference version won the **Best Paper Award** of IEEE International Conference on Communications (ICC) 2017)
- [2] B. Choi, J. Sohn, S. W. Yoon and J. Moon, "Secure Clustered Distributed Storage Against Eavesdroppers," IEEE Transactions on Information Theory, 2019.
- [3] H. Park, D. Lee and J. Moon, "LDPC Code Design for Distributed Storage: Balancing Repair Bandwidth, Reliability, and Storage Overhead," IEEE Transactions on Communications, vol. 66, no. 2, pp. 507-520, Feb. 2018.
- [4] B. Choi, J. Sohn, D.-J. Han and J. Moon, "Scalable Network-Coded PBFT Consensus Algorithm," IEEE International Symposium on Information Theory, 2019.
- [5] S. W. Yoon, J. Seo and J. Moon, "TapNet: Neural Network Augmented with Task-Adaptive Projection for Few-Shot Learning," International Conference on Machine Learning (ICML) 2019.
- [7] D.-J. Han, J. Moon, D. Kim, S.-Y. Chung and Y. Lee, "Combined Subband-Subcarrier Spectral Shaping in Multi-Carrier Modulation under the Excess Frame Length Constraint," IEEE Journal on Selected Areas in Communications, 2017.
- [8] J. Sohn, S. W. Yoon and J. Moon, "Pilot Reuse Strategy Maximizing the Weighted-Sum-Rate in Massive MIMO Systems," in IEEE Journal on Selected Areas in Communications, 2017.
- [8] M. Choi, J. Kim and J. Moon, "Wireless Video Caching and Dynamic Streaming under Differentiated Quality Requirements," IEEE Journal on Selected Areas in Communications, April 2018.

| | |
|--|--|
|  <p>Laboratory for Information Transmission</p> |  <p>Supported by the Ministry of Science and ICT Beyond 5G Mobile Communication Research Lab.</p> |
| <p>■ Current members of the Lab. (in 2019 Fall Semester) 1 Research Professor, 1 Post Doc. 10 Ph.D Students, 5 master's Students</p> | <p>■ Contact information Professor: Room 715, IT Convergence building (N1), TEL: 042-350-7420 Laboratory: Room 718, IT Convergence building (N1), TEL: 042-350-7520 Website: http://lit.kaist.ac.kr</p> |
| <p>■ Research Areas In Laboratory for Information Transmission (LIT), we conduct researches on theoretical analysis and practical design of transmission technologies in modern wireless communication systems. Especially, extensive researches on performance analysis and development of 5G and beyond 5G mobile communication technologies are actively performed. LIT has been selected as the Research Laboratory of Beyond 5G (B5G) mobile communication supported by the Ministry of Science and ICT, and we aim to acquire original technologies for B5G communications. Detailed research topics are listed below.</p> <ul style="list-style-type: none"> - Massive MIMO Massive multiple input multiple output (MIMO) is a technology that increases the transmission speed and reliability of wireless communication by using several tens or hundreds antennas in base stations. Our research topics are power-efficient and intelligent transmission/reception schemes of massive MIMO system. - Machine learning based wireless communication Adopting machine learning and deep learning in communication systems, we are solving problems that are not easy with conventional methods, or improving the performance. - Beamforming scheme at mmWave and terahertz bands - Filter bank multi-carrier (FBMC) communication - Small cell network with wireless backhaul - Simultaneous wireless information and power transmission (SWIPT) system <p>Currently, ongoing research projects include "Development on The Disruptive Technologies for Beyond 5G Mobile Communications Employing New Resources", "Development of 200 Gbps MIMO RF Front-end", "Simultaneous Transmission of Information and Power", "KOREA-EU International Joint Research on 5G", "Machine Learning-based NAND Flash Memory Management Scheme"</p> | |
| <p>■ Recommended courses: Signal and systems, Probability and random processes, Communication engineering</p> <p>■ Career after graduation: The LIT has produced 16 Ph.Ds and 34 Masters, and the alumni have been active in various fields in research institutes such as the Agency for Defense Development (ADD), Electronics and Telecommunications Research Institute (ETRI), Korea Aerospace Research Institute (KARI), companies, schools and government agencies.</p> | <p>■ Introduction to other activities besides research The LIT has two workshops in winter and summer every year, celebrates the birthdays of individual students and makes friendships among professor and students. The lab. members interact with alumni every year through homecoming day, and the alumni share their experiences in various cases such as careers and researches.</p> |
| <p>■ Introduction to the Lab. The LIT has a vision becoming world class communication laboratory. We aim to establish basic research and development of core technologies in information theory, signal processing and communication, and to perform researches for advanced theoretical topics as well as practical issues. By doing so, we obtain creative and practical skills necessary for the development of communications, and become high-quality engineer who will play a key role in the field of communications industry and academia.</p> <p>In order to achieve a comfortable and enjoyable research environment for students, we are helping to maximize individual passion and ability in a free and pleasant atmosphere based on mature individualism.</p> | |
| <p>■ Recent research achievements ('17~'19) Publications: 16 International Journals, 15 International Conferences Awards: Best paper award for KICS Fall 2017: "Performance Analysis on 5G New Radio (NR) Polar Codes" Bronze Paper award in the 24th Samsung Electronics Human Tech.: "Superposition Transmission of Uplink SCMA"</p> | |

| | | |
|---|--|---|
| <h1 style="margin: 0;">INFORMATION SYSTEMS LABORATORY (ISL)</h1> | | <p>■ Contact Information</p> <ul style="list-style-type: none"> •Prof.: N1 building #912 •TEL: 042-350-7429 •Lab.: N1 building #920 •TEL: 042-350-7529 •Website: https://csuh.kaist.ac.kr |
| <p>■ Members: • PhD students 2 • Master students 2 • Undergraduate student 1</p> <p>■ Alumni: • Postdoctoral Fellow 1 (Professor at UW Madison ECE) • PhD/Master/Undergraduate 7 (Professor at Chosun Univ, PhD students at MIT/UC-Berkeley/UIUC, Research scientists at Samsung and Lunit)</p> | | |
| <p>■ Research interests</p> <p>Our research interests center on information theory and its applications to a widening array of system contexts, ranging from traditional systems (such as communication [1,3,8] and storage [2] systems) to modern systems (like search engine [4,7], social networks [5], recommendation [6,10] and self-driving systems [9,11]). Recently we have found important roles of information theory in spotlight fields that have been revolutionized during the past case: machine learning and deep learning. Motivated by the recent witness of such big roles, we have advanced an interdisciplinary field that spans information theory and machine learning. The recent achievements are listed in a table below.</p> | | |
| | Achievements | Recognitions |
| 1 | Driving in the matrix: Self-driving systems using a video game [9,11] | <ul style="list-style-type: none"> • Deep-learning-based collision prediction systems using a game simulator • A paper accepted in AAAI (oral presentation, rate = 6.48%) • Won a Paper Award in JCCI • Received the two-year grant from the US Air Force (2019.4 ~ 2021.3) |
| 2 | AI tutor: Recommender systems for education [6] | <ul style="list-style-type: none"> • Succeeded in commercialization (Product app: SANTA TOEIC) • Received +W50 billion investment in total (Company: Riiid) • Relevant papers accepted in NeurIPS/KDD workshop |
| 3 | Recommender systems with social networks [10] | <ul style="list-style-type: none"> • Improving prior algorithms in an order of magnitude. • A paper accepted in NeurIPS/KDD workshop |
| 4 | Development of a DNA sequencer [5] | <ul style="list-style-type: none"> • Developed a computationally efficient algorithm for DNA sequence that achieves the information-theoretically optimal performance. • A paper accepted in ICML |
| 5 | Real-time search engine [4,7] | <ul style="list-style-type: none"> • Speeded up Google's search engine (PageRank) in an order of magnitude • Relevant papers accepted in NeurIPS/ICML • IEIE/IEEE Joint Award, IEIE Haedong Young Engineer Award, Bell Labs Prize finalist |
| <p>■ Intensive collaborations with prominent scholars in renowned institutes</p> <ul style="list-style-type: none"> • MIT: Lizhong Zheng (fairness machine learning) • UC Berkeley: Kannan Ramchandran (general purpose AI) • UMN: Soheil Mohajer (recommender systems) • Stanford: David Tse (network information theory) • UW Madison: Kangwook Lee (self-driving cars) • NUS: Vincent Tan (generative adversarial networks) | | |
| <p>■ Recommended courses</p> <ul style="list-style-type: none"> • EE202: Signals and systems • EE210: Probability and introductory random processes • MAS212: Linear algebra • EE326: Introduction to information theory and coding • EE424: Introduction to optimization techniques | | |
| <p>■ Our visions</p> <ol style="list-style-type: none"> 1. Make impacts: We aim both at theory and practice, thereby making impacts upon a wide range of fields. Specifically we intend to design theory-inspired optimal system architectures that can lay the foundation of various tomorrow systems. 2. Be an independent researcher: We desire to produce strong students with fundamentals and practical skills. If you wish to be an independent researcher who can do critical thinking and do great works, ISL is the right place. Prof. Suh offers weekly one-to-one meetings with every student, mentoring how to (i) formulate research problems; (ii) solve the problems; (iii) write papers; (iv) give presentations in clarity. 3. Work happy: We have regular hang-outs (e.g., playing sports, having fine dining). | | |
| <p>■ Recent publications (Google Scholar Citations ~ 4,883)</p> <p>[1] C. Suh and D. Tse, "Feedback capacity of the Gaussian interference channel to within 2 bits," IEEE Transactions on Information Theory, 2011(the conference version won the Best Student Paper Award).</p> <p>[2] C. Suh and K. Ramchandran, "Exact-repair MDS code construction using interference alignment," IEEE Transactions on Information Theory, vol. 57, no. 3, pp. 1425-1442, Mar. 2011.</p> <p>[3] C. Suh, M. Ho and D. Tse, "Downlink interference alignment," IEEE Transactions on Communications, vol. 59, no. 9, pp. 2616-2626, Sep. 2011 (won the 2013 IEEE Communications Society Stephen O. Rice Prize).</p> <p>[4] Y. Chen and C. Suh, "Spectral MLE: Top-K rank aggregation from pairwise comparisons," ICML, July 2015 (Bell Labs Prize finalist).</p> <p>[5] Y. Chen, G. Kamath, C. Suh and D. Tse "Community recovery in graphs with locality," ICML, 2016.</p> <p>[6] K. Lee, J. Chung, and C. Suh, "Large-scale and interpretable collaborative filtering for educational data," KDD Workshop, 2017.</p> <p>[7] M. Jang, S. Kim, C. Suh, S. Oh, "Optimal sample complexity of M-wise data for top-K ranking," NeurIPS, 2017.</p> <p>[8] C. Suh, J. Cho and D. Tse, "Two-way interference channel capacity: How to have the cake and eat it too," IEEE Transactions on Information Theory, June 2018 (solved an Open Problem in Network Information Theory Society).</p> <p>[9] K. Lee, H. Kim and C. Suh, "Simulated+Unsupervised learning with adaptive data generation and bidirectional mappings," ICLR, 2018.</p> <p>[10] K. Ahn, K. Lee, H. Cha, C. Suh, "Binary rating estimation with graph side information," NeurIPS, 2018.</p> <p>[11] H. Kim, K. Lee, G. Hwang and C. Suh, "Crash to not crash: Learn to identify dangerous vehicles using a simulator," AAAI, 2019.</p> <p>[12] J. Cho and C. Suh, "Wasserstein GAN Can Perform PCA," Proceedings of Allerton on Communication, Control, and Computing, Sep. 2019.</p> | | |

| | |
|--|---|
|  | <p>■ Contact information</p> <p>Professor: N1 #614 TEL: 042-350-3484 Lab: N1 #619 TEL: 042-350-5484 Website: https://sisrel.kaist.ac.kr/</p> |
| <p>■ Current state of the Lab (in 2019 Fall Semester)</p> <p>Postdoctoral Fellows : 0 PhD Students: 6 Master's Student: 3</p> | |
| <p>■ Research Interests</p> <p>▷ Reinforcement Learning, Statistical Learning, and Information Geometry</p> <p>On the verge of the fourth industrial revolution, machine learning based approaches to large-scale control problems such as traffic or power distribution systems, are so important, and reinforcement learning, the study of optimal policy search in complex and uncertain environments, is crucial. Through theoretical approaches from statistics, probability theory, and/or information geometry, we are seeking for novel breakthroughs in reinforcement learning.</p> <p>■ Recent Works</p> <p>▷ Algorithms</p> <p>We proposed an Adaptive Multi-Batch Experience Replay scheme that uses batch samples of past policies for the update, adaptively choosing the number of past batches based on the average importance sampling (IS) weight. It significantly increases the speed and stability of the algorithm on various continuous control tasks.</p> <p>▷ Exploration</p> <p>Value and policy functions are usually represented by neural networks, so finding the optimal parameters for them is the key. Since the parameter space is huge and the objective function is far from nice, the search for global optima is challenging. To explore the parameter space more efficiently, we proposed a method using multiple workers where they exchange information about the parameter space with each other.</p> <p>▷ Multi-Agent RL</p> <p>We proposed a new technique named block-dropout, which can be applied to multi-agent deep reinforcement learning. Block-dropout effectively handles the high input dimension in multi-agent reinforcement learning with information exchange, where each agent uses the information of other agents to train its policy.</p> <p>▷ Sparse-Reward RL</p> <p>We proposed a new intrinsic reward generation method for sparse-reward RL, based on an ensemble of dynamics models. Numerical results show that for a variety of representative locomotion tasks, the proposed method outperforms the state-of-the-art algorithm that only uses a single dynamics model.</p> | |
| <p>■ Recommended Courses</p> <p>We recommend interested students to take basic courses in mathematics such as Analysis, Linear Algebra, Optimization Techniques, and Probability and Statistics; and machine learning related courses such as Introduction to Big Data and Reinforcement Learning.</p> | <p>■ Career Paths After Graduation</p> <p>SISReL graduates are playing active roles in research and development activities as professors in academia, as researchers in national research institutes such as ETRI, ADD, NSRI, or as researchers in industry.</p> |
| <p>■ Recent Research Achievements ('17~'19)</p> <p>▷ Won 1st Place in AI World Cup 2018</p> <p>▷ Woojun Kim, Myungsik Cho, and Youngchul Sung, "Message-dropout: An efficient training method for multi-agent deep reinforcement learning," the 33rd AAAI Conference on Artificial Intelligence (AAAI) 2019, Honolulu, Hawaii, USA Jan. 2019</p> <p>▷ Seungyul Han and Youngchul Sung, "Dimension-Wise Importance Sampling Weight Clipping for Sample-Efficient Reinforcement Learning," the 36th International Conference on Machine Learning (ICML) 2019, Long Beach, CA, USA, Jun. 2019</p> | |

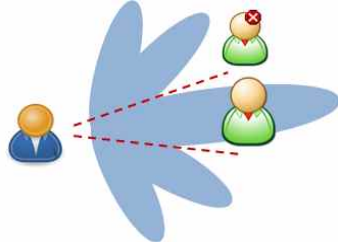
| | |
|---|---|
|  <p>Statistical Signal Processing (SSP) Laboratory</p> | <p>■ Contact information</p> <p>Advisor: EE Bldg. #5202 TEL: 042-350-3445 Lab.: EE Bldg. #4219 TEL: 042-350-5445 Website: http://bungae.kaist.ac.kr</p> |
| <p>■ Current state of the Lab. (as of 2019 Fall Semester)</p> <p>Postdoctoral Fellows: 1 PhD Students: 0 Master's Student: 1</p> | |
| <p>■ Research Areas</p> <p>Our major concern has been on various problems in signal detection, the basis of communications and signal processing. Specifically, we have a good deal of experience in a variety of research on weak signal detection, orthogonal frequency division multiplexing, and code division multiple access systems, from which we have been successful in securing several interesting results. Recently, we are aiming at acquiring essential techniques in intelligent distributed information processing technology for future resource-saving systems under real-time massive-data circumstances.</p> <p>MIMO Decoding</p> <p>With multiple transmit and receive antennas we can not only reduce the effects of multipath fading but also increase frequency efficiency in wireless communication channel with multipath fading environment. Due to the increased interference resulting from the higher degree of spatial multiplexing when the number of transmit antennas increases, designing efficient decoding schemes for MIMO systems becomes a major issue. We have tried to design new suboptimal decoders based on multiple hypothesis testing for higher efficiency.</p> <p>Spectrum Sensing</p> <p>The purpose of spectrum sensing is to decide whether the primary user is currently using the allocated frequency band or not. In most of the schemes for spectrum sensing, it is usually assumed that the noise is Gaussian. However, non-Gaussian (impulsive or heavy-tailed) nature of noise prevails in some systems. We have worked on spectrum sensing schemes for cognitive radio networks with multiple receive antennas under impulsive noise environments</p> <p>Kernel Feature Extraction</p> <p>Information processing system for big/high dimensional data requires fast processing speed to process real time multimedia data collected from a large number of sensors. In such a case, extracting useful information from the raw data via pre-processing is essential. We have obtained new feature extraction techniques with computational efficiency for the processing of high dimensional data.</p> | |
| <p>■ Recommended courses & Career after graduation</p> <p>Courses on probability and random processes and mathematics would be quite helpful for any research on signal processing and communications. About half of the Ph.D graduates from the SSP work in academia and the others work in research labs.</p> | <p>■ Introduction to other activities besides research</p> <p>We do our best in research and at the same enjoy personal daily life via various activities. For example, we enjoy tennis, table tennis, volleyball with foot, and short trek whenever possible. Sometimes, we play 'mighty' also.</p> |
| <p>■ Introduction to the Lab.</p> <p>In the 'Statistical Signal Processing Research Forum', organized by the SSP several times a the year and normally supported by the Detection and Estimation Group of Korean Institute of Communications and Information Sciences (KICS), interesting topics and results are presented and discussed. While participating in the Forum, current students will have unique opportunities for discussing academic and personal matter with graduates of the SSP.</p> | |
| <p>■ Research achievements</p> <p>[1] National Research Laboratory (Apr. 2005 – Present) [2] Published one textbook in probability and random processes <i>(Fundamentals of Random Variables and Statistics, Freedom Academy, 2017)</i> [3] Eleven Publications (Nine and two papers in international and Korean journals, respectively, for 2017-2019)</p> | |

| | |
|--|--|
| <h1>InfoLab</h1> <p>Information Theory, Communications and Security</p> | <p>■ Contact information Professor : sihyeon@postech.ac.kr TEL : 054-279-2364 Lab. : TBD TEL : 054-279-5022 Website : https://sites.google.com/view/postech-infolab</p> |
| <p>■ Current state of the Lab. (in 2019 Fall Semester) PhD Students: 0 Master's Student: 5 (4 students are becoming PhD students in 2020)</p> | |
| <p>■ Research Areas</p> <p>● Wireless Communications We study the fundamentals of wireless communications. In particular, we take an information-theoretic approach, which has provided the fundamentals and key intuitions for the development of modern communication systems. In this area, our recent research focuses on (but not limited to) the following topics:</p> <ul style="list-style-type: none"> - 5G communications, in particular low latency and low power communications - Distributed networks  <p>● Physical Layer Security Physical layer security can be a new approach to complement traditional upper layer techniques, in a sense it provides fundamental security regardless of computing power of an adversary, does not require sharing a secret key, and is easy to implement in distributed networks. Our recent research topics are:</p> <ul style="list-style-type: none"> - Secure communication - Covert communication (or Communication with low probability of detection)  <p>● Privacy Protection In big data era, every small data is collected and analyzed with various intentions. However, such a utilization of information leads to the possibility of severe privacy loss from each individual's point of view, and it should be accompanied by appropriate privacy protection strategies. Our recent research interests are:</p> <ul style="list-style-type: none"> - Privacy protection in machine learning - Smart meter privacy  | |
| <p>■ Recommended courses Backgrounds in probabilities, communications, machine learning (optional)</p> <p>■ Career after graduation Communications and security technologies are highly demanded research areas both in industry and academia.</p> | <p>■ Introduction to other activities besides research</p> <ul style="list-style-type: none"> - Various activities such as MT, sports, board game, hiking etc. - Two weeks vacations a year |
| <p>■ Introduction to the Lab. InfoLab started in 2017 at POSTECH and is moving to KAIST in 2020. Our research focuses on communications, information security and privacy protection. International collaborations are highly encouraged.</p> | |
| <p>■ Recent research achievements ('17~'19)</p> <ul style="list-style-type: none"> - 10 SCI papers (Top journals such as IEEE Trans. Information Theory, IEEE Trans. Information Forensics and Security, IEEE Trans. Communications) - 5 International conference papers (Top conferences in information theory such as IEEE ISIT and IEEE ITW) | |

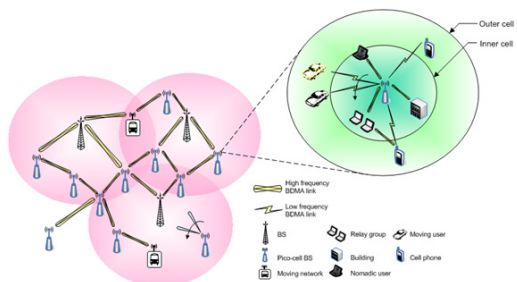
| | |
|---|---|
|  <p>digitalcommunicationslab. Digital Communications Laboratory</p> | <p>■ Contact information Professor: Room 217, CHIPS(N26) TEL: +82-42-350-3437 Lab: Room 210, CHIPS(N26) TEL: +82-42-350-4412 Website: http://kalman.kaist.ac.kr</p> |
| <p>■ Current state of the lab (2019 Fall) Ph.D. Students: 3 Master Students: 2</p> | |
| <p>■ Research Areas Matrix Completion by Deep Learning and Application in the Recommender Systems The objective of matrix completion is to complete a low-rank matrix from its incomplete version with many missing entries. Such a matrix completion algorithm plays an important role in which only a part of the entire data can be acquired, such as recommender systems. We consider a deep neural network called autoencoder for matrix completion. We analyze an autoencoder consisting of a nonlinear encoder followed by a linear decoder and observe that the autoencoder estimates the feature matrices sequentially. In addition, we utilize not only rating information but also side information (ex. genre, age) to improve the performance of the recommender systems.</p> <p>Semi-Supervised Learning Semi-Supervised Learning (SSL) provides a powerful framework for leveraging unlabeled data when labels are limited or expensive to obtain. SSL algorithms based on deep neural networks have recently proven successful on standard benchmark tasks. We are working on a new algorithm to challenge the state-of-the-art techniques.</p> <p>Massive MIMO systems and mm-wave communications Recently massive Multiple-Input Multiple-Output (MIMO) and mm-wave systems have received considerable attention as useful tools for achieving the target capacity of 5G mobile communications (e.g. 1,000 times the 4G system capacity). Both massive MIMO and mm-wave systems employ a large number of antennas and require novel signal processing techniques that can increase the capacity with minimal overhead. Compressed sensing is a promising technique for these systems. We are developing channel estimation and beamforming techniques for massive MIMO and mm-wave systems based on compressed sensing.</p>  | |
| <p>■ Recommended courses & Career after graduation It is recommended to have a good background in probability, random process, artificial intelligence and digital signal processing. Among the 44 Ph.D. graduates of our lab, 3 of them work in the USA, 9 are professors of Korean universities and the rest work for Korean industries and National labs.</p> | <p>■ Introduction to other activities besides research We have Summer/Winter student workshops.</p> |
| <p>■ Introduction to the Lab. 44 Ph.D and 80 M.S graduates have been supervised by Prof. Yong H. Lee since 1989. They were the recipient of various awards including the 1997 Telecommunications Review Best Paper Award, the 2001, 2011, and 2016 JCCI Best Paper Award, the 2015 KICS Best Paper Award, the Samsung Humantech Paper Award (2006 and 2008 Silver, 2008 and 2011 Bronze), and the Intel Student Paper Contest (2006 Gold). Our lab supports students' participation in various conferences and workshops.</p> | |
| <p>■ Recent research achievements ('16~'19): 21 Publications (9 International papers & 12 Domestic papers) - Selected Journals and Conference papers [1] Kiwon Lee, Hyeonsoo Jo, Hyoji Kim and Yong H. Lee, "Basis Learning Autoencoder for Hybrid Collaborative Filtering," in Proc. of IEEE Machine Learning for Signal Processing, Pittsburgh, U.S.A., October, 2019. [2] Hyoji Kim, Gye-Tae Gil and Yong H. Lee, "Two-Step Approach to Time-Domain Channel Estimation for Wideband Millimeter Wave Systems with Hybrid Architecture," in IEEE Transactions on Communications, Vol 67 pp. 5139-5152, July 2019. [3] Kiwon Lee, Yong H. Lee, Changho Suh, "Alternating Autoencoders for Matrix Completion," in Proc. of IEEE Data Science Workshop, Lausanne, Switzerland, June, 2018.</p> | |

| | |
|---|--|
| <h1>Information Theory & Machine Learning Lab</h1> <p>정보이론 및 기계학습 연구실</p> | <p>■ Contact information Professor : N1-615 TEL : 042-350-3481 Lab. : N1-618 TEL : 042-350-5481 Website : http://itml.kaist.ac.kr</p> |
| <p>■ Current state of the Lab. PhD Students: 6 Master's Student: 4</p> | |
| <p>■ Research Areas</p> <p>- Introduction on Information Theory Invented by Claude. E. Shannon in 1948, information theory has been influencing fundamental theory in various fields related to information. Back in 60 years ago when the word 'Digital' was not familiar enough, Shannon already built the theoretical background of digital communication. Finally in the 90s, devoted by the leap of the electronic device technology, Shannon's theoretical result became implementable and has been applied to most digital devices including HDTV, MP3, 4G LTE, and WiFi. Due to these achievements Shannon is known as the father of the digital era.</p> <p>- Introduction to Machine Learning One of the main contributions that led information theories' application to practical digital system from the 90s is by the Moore's law. Since the 90s, improvement on device density made digital signal processing and information processing possible, which contributed on rapid transition to majority of communication and signal processing devices from analog to digital. Moore's law on processing power and memory device density has been valid for about 20 years, and such improvement has been powerful enough to show performance on machine learning fields, such as deep learning. Deep learning that consists of deepened neural networks showed major breakthrough, achieving superhuman performance on various fields, including video recognition, speech recognition, and Go. Despite of recent hype on deep learning technologies, it's theoretical background has not been established well. This phenomenon in deep learning shows contrast to majority of research fields, where technological development follows the theory. Therefore, many researchers are seeking to answer the fundamental question of the deep learning's performance and application. Such answers will contribute to accelerate the development of the deep learning. ITML focus on the research to understand the principle theory of machine learning and to develop the new machine learning structure by the fundamental theory, such as information theory.</p> | |
| <p>■ Recommended courses Basic probability theory, Signals and systems, Digital signal processing, Communication engineering, Introductions to information theory and coding theory, machine learning, and artificial intelligence. Also, we encourage taking fundamental courses in Mathematics and Physics department.</p> <p>■ Career after graduation Post Docs, National Research Institute, Corporate Research Institute(Samsung ,LG)</p> | <p>■ Projects</p> <p>[1] Information Theoretic approach to deep learning techniques and structures. [2] Development of deep learning based drone tracking radar technologies. [3] Applications in Big data Analytics: Development of efficient distributive data storage [4] Research on intelligent IoT applying deep reinforcement learning.</p> |
| <p>■ Introduction to the Lab. We focus on understanding the fundamental principles of machine learning by using mathematical tools such as information theory and applying them to various fields. We are looking for researchers with a track record in machine learning or information theory.</p> | |
| <p>■ Recent research achievements ('16~'18)</p> <p>[1] Citation counts on papers and patent: Above 7000 [2] Development of LDPC codes that achieve the Shannon limit most closely(Above 3000 citation counts) [3] Unified Theory on network information theory: Key theorem that unifies the hundreds of independent information theoretic results of the society.</p> | |

| | |
|--|--|
| <h2 style="margin: 0;">Inference and Information for Data Science (IIDS) Lab.</h2> | <p>■ Contact information</p> <p>Professor : ITC Building (N1) 206 TEL : 042-350-7441 Lab. : ITC Building (N1) 213 TEL : 042-350-7541 Website : http://iids.kaist.ac.kr</p> |
| <p>■ Current state of the Lab. (in 2017 Fall Semester)</p> <p>Post Doc: 0 PhD Students: 3 Master's Student: 2</p> | |
| <p>■ Research areas: Data science, statistical inference, information theory, and machine learning.</p> <p>The goal of our research group is to provide a theoretical and algorithmic framework for information science that can lead to efficient strategies for assessing, gathering, extracting, and exploiting information. In the era of big data, we want to fully utilize the large volumes and richness of data sets to efficiently infer the real-world phenomena behind the data. Information-theoretic concepts and tools are useful in data science, especially to establish fundamental limits and to explore trade-offs in extracting information from data sets. To deal with new challenges originated from practical concerns in engineering information processors for big data, we also need new techniques and concepts beyond the classical information-theoretic solutions.</p> <p>Our research focus is on developing a theoretical framework for data science that copes with practical concerns such as timeliness in decision making, efficient usage of limited sensing resources, and computational efficiency in data processing. We develop algorithms for data acquisition and information recovery problems and provide performance guarantees for these algorithms by using tools from probability theory, information theory, and stochastic analysis.</p> <div style="text-align: center;">  </div> <p style="display: flex; justify-content: space-around;">Raw Data Useful Information</p> <p>■ Recent research topics:</p> <ul style="list-style-type: none"> - Optimal data acquisition: design sensing patterns to generate useful data in estimating an unknown target variable with limited sensing resources - Value-centered bit data processing: design principles to correctly assess the value of information and develop information extraction strategies for big data processing based on the quantified value of information - Deep Learning Algorithm: theoretical understanding on why deep learning works well - Graph Inference Problems: obtaining useful information from graph that can be obtained from social networks | |
| <p>■ Recommended courses & career after graduation</p> <p>Recommended courses are probability, information theory, statistical inference, and random process. Mathematical background (in probability, statistics, or analysis) and/or programming skills (e.g., Python, C++, or MATLAB) would be helpful to start research in our lab. Data science is a rapidly emerging area with many possible career opportunities both in industry and academia.</p> | <p>■ Introduction to other activities besides research</p> <p>We are a very young research group at KAIST, started in June 2017. Students who would join our group can freely suggest ideas on group activities they would like to have. Prof. Hye Won Chung is willing to provide great support for students in our group and she tries to be always available for students in meeting and discussing ideas.</p> |
| <p>■ Introduction to the Lab</p> <p>As a recently established research group, we are welcoming new students who are passionate in exploring interesting ideas in data science and statistical inference. We encourage open discussions and collaborations in defining research problems and developing ideas.</p> | |
| <p>■ Recent research achievements ('16~'19)</p> <p>Prof. Hye Won Chung completed her Ph.D in 2014 at MIT and joined KAIST as an assistant professor in June, 2017 after 3 years of employment as a research fellow in University of Michigan.</p> <ol style="list-style-type: none"> [1] Weak Detection of Signal in the Spiked Wigner Model, ICML, 2019 [2] Parity Crowdsourcing for Cooperative Labeling, arXiv:1809.10827, 2018 [3] Shallow Neural Network can Perfectly Classify an Object following Separable Probability Distribution, ISIT, 2019 [4] Unequal Error Protection Querying Policies for the Noisy 20 Questions Problem, <i>IEEE Transactions on Information Theory</i>, 2018 [5] Bounds on Variance for Symmetric Unimodal Distributions, <i>IEEE Transactions on Information Theory</i>, 2017 [6] On Capacity of Optical Communications over a Lossy Bosonic Channel with a Receiver Employing the Most General Coherent Electro-Optic Feedback Control, <i>Physical Review A</i>, 2017 | |

| | |
|---|---|
|  <p>Ubiquitous Mobile Life System Laboratory</p> | <p>Contact information</p> <p>Professor : N26 CHiPS #210 Tel. : 042-350-8067 Lab. : N26 CHiPS #210 Mobile : 010-4470-5023 Website : http://umls.kaist.ac.kr</p> |
| <p>Current status of the Lab. (in 2019 Fall Semester) PhD Students: 10 Master's Student: 2</p> | |
| <p>Research Areas</p> <p>Mobile Communication System (Multi-dimensional Antenna and Beamforming) For future standardization, P2BDMA technology has been developed by utilizing pattern, polarization, beam and MIMO resources. Also, pattern, polarization and beam division mobile communication system was developed in the cellular and mmWave frequency band.</p> <p>Mobile Communication System (Time, Frequency and Space Resource Management) Through the integrated cell/resource management, algorithm to control interference among users is researched when there are multiple base stations and users. Furthermore, to guarantee valuable QoS in the areas with high traffic density and fast moving users, core technology of MAC layer supporting gigabit capacity transmission in wireless backhaul is researched in the unlicensed band.</p> <p>Wireless Power Transfer Efficient wireless power transfer technology is developed based on magnetic resonance. Core technology of real time wireless power transfer for the sensors embedded in the building is being developed. Also, static and dynamic wireless power transfer technology has been developed to guarantee seamless wireless charging during the operation of transportation system.</p> <p>Genome sequence analysis based precision diagnosis. A new approach was made to explain the phenotype, phylogenesis and the biological phenomenon. Modeling of genetic sequence and analysis of RE array are researched based on information and computational engineering. From these researches, genome based biomarkers and accurate diagnosis algorithms have been developed.</p> |  |
| <p>Recommended courses & Career after graduation Communication Engineering, Communication Systems, and Wireless Networks are recommended courses. There are total 101 alumni(47 doctors and 54 masters), professor in university, researchers in research institute (e.g. ETRI, ADD), companies(e.g. Samsung Electronics Co. Ltd., LG Electronics Inc.) or mobile service operators(e.g. KT, SK telecom, LG Uplus), and etc.</p> | <p>Other activities except research Every year, summer membership training and workshop have been held. There are also activities like strawberry party, homecoming, monthly congregate dining and biweekly exercises(e.g. soccer, basketball).</p> |
| <p>Introduction to the Lab. Ubiquitous Mobile Life Systems Lab. is an experienced research and development group which has contributed to the advancement of mobile communication, wireless power transfer and bioinformatics. Research area consists of future wireless mobile communication, long distance wireless power transfer, polarization communication, and precise diagnosis. Weekly face-to-face meeting with professor and collaborative work among members will help the convergence research. Joining the cooperative project supported by companies or government provides opportunity to learn theory and practice at the same time. Many graduate students have been participating in the international conference and a large number of papers have been published. UMLS lab will welcome anyone who wants to be a member.</p> | |
| <p>Recent research achievements ('14~'18) -Overall publications 194 international journals, 304 international conference papers, 72 domestic journals, and 193 domestic conference papers -Overall patents 105 international patents, 415 domestic patents -Overall international standard 3 IEEE 802.16e, 5 3GPP2, 1 IEEE 802.16j, 1 IEEE 802.16m, 2 IEEE 802.16m, 5 IEEE 802.16ppc -Representative publications [1] M. Kim, N.I Kim, W. Lee, D.H. Cho, "Deep Learning-Aided SCMA", <i>IEEE Communications Letters</i>, Jan. 2018. [2] G. Han, D.H. Cho, "Genome classification improvements based on k-mer intervals in sequences", <i>Genomics</i>, 2018. -Projects Wireless power transfer technology (Top 10 emerging technologies in 2013 by World Economic Forum, The 50 Best Inventions of 2010 by TIME) 5G mobile communication with Pattern/Polarization Beam Division Multiple Access (2016 Excellent National R&D 100) Beamforming-based multi-channel radio resource integration technology for capacity increasing of 5G communication (2017 KAIST Top 10 Patents)</p> | |

| | |
|--|---|
|  | <p>■ Contact information Professor : N1 712 TEL : 042-350-7426 Lab. : N1 720 TEL : 042-350-7526 Website : http://wcslab.kaist.ac.kr</p> |
| <p>■ Current state of the Lab. (in 2019 Fall Semester) Postdoctoral Fellows: 1 Ph.D Students: 9 Master's Student: 5</p> | |
| <p>■ Research Areas Wireless Communication Systems Lab (WCSL) carries out advanced research on academic and technological fronts in wireless communications. Our research is focusing on building up theoretical fundamentals of advanced wireless communication systems, using various mathematical tools such as optimization, stochastic geometry, and information theory. We find our applications to 5G, wireless edge caching/computing, vehicular communications, IoT, wireless power transfer, wireless distributed ledger technology, and machine learning for the advance of wireless communications</p> <p>5G Wireless communication systems We have developed key techniques enabling 5G for ultra-low latency, ultra-reliability, high transmission rate, and massive connectivity, such as multiple antenna (MIMO), interference management, and D2D communication. We have published the most quoted article in the area of 5G (about 3,600 citations based on Google scholar). We are recognized as a world-leading research group developing key technologies of 5G wireless communication systems.</p> <p>Vehicular communications Vehicular communications caught a great attention as a core technology for future driving systems, such as connected cars and autonomous driving cars. Our research is mainly focusing on developing novel techniques that guarantee reliable and real-time V2X (Vehicle-to-everything) communications. Specifically, we aim to develop a new paradigm technology for vehicular communications by merging the conventional radar and mmWave communication systems into a single integrated system.</p> <p>Wireless Edge Caching and Computing Communication, computing, and caching (3C) will converge in future wireless networks. Wireless edge nodes will collaboratively carry out specific tasks, by computing in a distributed way, exchanging data, and exploiting prefetched (cached) data, to reduce task completion time and consumed power. This convergence essentially leads a new paradigm of wireless communication system design. In these regards, Our research aims at devising break-through techniques to efficiently integrating them and building up a new framework of 3C convergence.</p> <p>Wireless Blockchain / wireless distributed ledger technology Distributed ledger technologies (DLTs), such as Blockchain, caught a significant interests of many people. because they are envisaged to have various applications. However, since current DLTs overlook wireless communication aspects, employing DLTs in wireless environments has some limitations. So we aim to build a novel DLT that is suitable for wireless environments and seek for applications that require wireless DLT.</p> | |
| <p>■ Recommended courses & Career after graduation Courses: matrix theory, analysis, statistics and probability theory, optimization theory, stochastic geometry, graph theory, and information theory, etc. Career: the present status of WCSL alumni includes professors, researchers/post-doctors affiliated with domestic/international corporation, research institute, and renowned universities.</p> | <p>■ Introduction to other activities besides research WCSL provides an environment that helps to do research freely. In addition to that, we often do exercises and go summer/winter workshops so that the members can become more close to each other. Ph.D students have opportunities of co-working with distinguished scholars in United States, Singapore, Finland, United Kingdom, etc., for a period of time.</p> |
| <p>■ Introduction to the Lab. Professor Choi serves as Editor for various renowned journals and has a reputation as a world-leading researcher in wireless communications. He always encourages students' enthusiasm, curiosity, and wondering and gives a lot of advices. Thus, if you join our lab, you can share academical inspiration with him and other colleagues. In addition, we have research seminars periodically which is very helpful to introduce each others' research and capture trends of research.</p> | |
| <p>■ Recent research achievements ('17~'19) [1] 17 top-tier journal papers (about 6 journal papers/year) [2] Gold Prize in the 24th Samsung HumanTech paper contest, 2018. [3] Chair of Executive Editorial Committee for IEEE Trans. on Wireless Communication [4]. Editor for other top IEEE Journals (Trans. on Vehicular Technology, Wireless Communications Letters, etc.)</p> | |

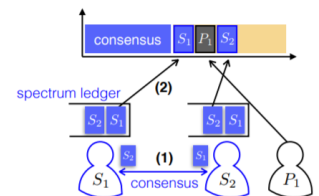
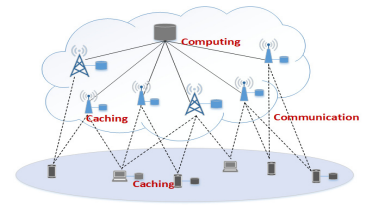
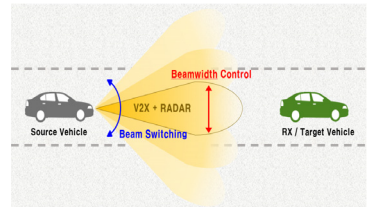

| | |
|--|--|
| <p>Intelligent Communications Systems Laboratory (ICL) 지능형 통신시스템 연구실</p> | <p>■ Contact information Professor : ITC Building (N1-305) TEL : 042-350-7460 Lab. : LG Innovation Hall (N24-2107) Website : icl.kaist.ac.kr</p> |
| <p>■ Current state of the Lab. (in 2019 Fall Semester) PhD Students : 4 Integrated PhD/Master's Students: 3</p> | |
| <p>■ Research Areas</p> <p>Intelligent Communications Systems Laboratory (ICL) conducts advanced research on 5G and beyond wireless communications systems in a physical layer perspective. We mainly focus on theoretical and algorithmic aspects of various problems in wireless communications systems using various tools such as signal processing, optimization, compressed sensing, machine learning, and information theory. Our application consists of massive MIMO, distributed reception, mmWave communications, and vehicular communications.</p> <div style="display: flex; justify-content: space-around;"> <div data-bbox="127 649 734 896"> <p>Massive MIMO</p> <p>Large antenna arrays to increase cell throughput Reduced out-of-cell interference</p> </div> <div data-bbox="813 649 1244 896"> <p>Distributed Reception</p> <p>◆ Person: Realize high data rate ◆ People: Exploit crowd of people ◆ Building: Full of IoT devices ◆ Military: Extremely reliable communication necessary</p> </div> </div> <div style="display: flex; justify-content: space-around; margin-top: 20px;"> <div data-bbox="127 940 734 1187"> <p>MmWave Communications</p> <p>~4 GHz LMDS (0.85 GHz, 1.6 GHz, 1.4 GHz) Unlicensed 7 GHz 10 GHz E-band Auctioned in 2000 - \$410,649,085 / 2,173 licenses Expected to be unlicensed Even more is available above 90GHz Proposed by FCC in 2015</p> </div> <div data-bbox="813 940 1436 1187"> <p>Vehicular Communications</p> </div> </div> | |
| <p>■ Recommended courses</p> <p>Recommended courses are probability, linear algebra, optimization, communication engineering, information theory, etc.</p> | <p>■ Introduction to other activities besides research</p> <p>ICL provides an enjoyable environment its students by promoting various leisure activities such as summer and winter workshops, sports, etc. ICL also promotes regular team lunch/dinner from pizza to fine dining.</p> |
| <p>■ Introduction to the Lab.</p> <p>The goal of ICL is to contribute to the technological advance in wireless communications systems through research. ICL aims to train each student as an independent researcher who can conduct their own research. The students can freely discuss their research ideas with Professor Junil Choi. Furthermore, ICL encourages the students to discuss with each other, thereby learning how to co-work and clearly deliver their ideas.</p> | |
| <p>■ Recent research achievements</p> <p>Publications ('17~'19) : 17 International Journals / 7 International Conferences</p> <p>Awards :</p> <ol style="list-style-type: none"> 1) IEEE Communications Society Stephen O. Rice Prize, 2019. 2) NRF and Elsevier Young Researcher Award, 2018. 3) KICS Joint Conference on Communications and Information (JCCI) Best Paper Award, 2018. 4) IEEE ComSoc AP Region Outstanding Young Researcher Award, 2017. 5) IEEE Signal Processing Society Best Paper Award, 2015. 6) IEEE Global Communications Conference (GLOBECOM) Best Paper Award, 2013. | |

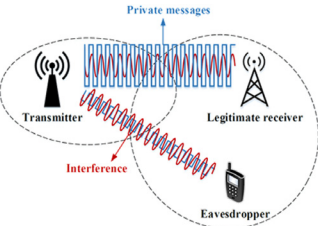
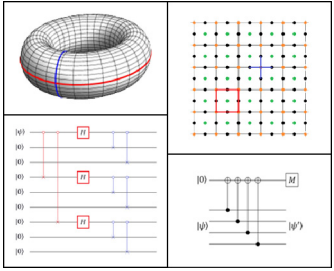
| | | |
|---|---|---|
| <h1 style="font-size: 2em; margin: 0;">CoCoA</h1> <p style="margin: 0;">Coding and Communications Lab</p> | | <p>■ Contact information</p> <p>Professor : ITC B/D (N1) No. 612 TEL : 042-350-7424 Lab. : ITC B/D (N1) No. 620 TEL : 042-350-7524 Website : http://cocoa.kaist.ac.kr</p> |
| <p>■ Current state of the Lab. (in 2019 Fall Semester)</p> <p>Postdoctoral Fellows : 1 PhD Students: 6 Master's Student: 5</p> | | |
| <p>■ Research Areas</p> <p>- Error Correction Codes with Machine Learning</p> <div style="display: flex; align-items: center;">  <div style="margin-left: 20px;"> <p>Error correction codes (ECC) protect information from the noisy environment. ECC are essential part of the digital communications and used in countless real world applications. CoCoA studies theoretical aspect of the advanced ECC like low density parity check and polar codes. We also develop machine learning based algorithms for ECC decoding, under the support of SK-Hynix and the National Research Foundation (NRF) of Korea.</p> </div> </div> <p>- Physical Layer Security</p> <div style="display: flex; align-items: center;">  <div style="margin-left: 20px;"> <p>Physical layer security, unlike cryptographic security which is based on high computational complexity, provides information theoretically guaranteed security. The physical layer security provides powerful and unique solutions to threats like eavesdropping, impersonating, and message modification. Under the support of Institute for Information & Communications Technology Promotion (IITP), CoCoA is studying innovative solutions to security issues in the 6-th generation wireless systems.</p> </div> </div> <p>- Quantum Computing for Artificial Intelligence</p> <div style="display: flex; align-items: center;">  <div style="margin-left: 20px;"> <p>Artificial Intelligence (AI) is advancing rapidly, but it is expected to reach the limit by hitting the limits of computer performance. To solve this problem, quantum computers have been extensively studied. CoCoA conducts researches on the quantum communication, information theory, and the quantum key distribution as well as error correction codes that are essential for quantum computers. We are currently working with the Smart Quantum Communication Research Center and Quantum Computing for AI Center supported by the ITRC.</p> </div> </div> | | |
| <p>■ Recommended courses & Career after graduation</p> <p>Recommended courses include introduction to information theory and coding, and basic probabilities. Graduates of CoCoA have excelled in leading information technology companies as Samsung Electronics, LG CTO, etc.</p> | <p>■ Introduction to other activities besides research</p> <p>CoCoA regularly conducts social activities in addition to research activities. Strawberry festivals, movie nights, and various other activities are organized to unite members of the lab.</p> | |
| <p>■ Introduction to the Lab.</p> <p>Coding and communications lab, leaded by Prof. Jeongsoeok Ha, seeks to develop theories and applications on state-art error correcting codes and communications topics. Our research interests include machine learning based smart error correcting codes, physical layer security and quantum communication. Researches are supported by various institutes and companies such as SK Hynix, NRF, ITRC, IITP. CoCoa has a very friendly lab atmosphere and we welcome everyone interested in our research topics.</p> | | |
| <p>■ Recent research achievements ('17~'19)</p> <p>International Journals: 9, International Conferences: 9, International Patents: 8, Domestic Patents: 10</p> <p>[1] S. Jeong, and J. Ha, "On the Design of Multi-Edge Type Low-Density Parity-Check Codes," IEEE Transactions on Communications, Accepted, 2019</p> <p>[2] S. Yun, I. Kim, and J. Ha, "Artificial Noise Scheme for Correlated MISO Wiretap Channels," IEEE Transactions on Vehicular Technology, Accepted, 2019</p> <p>[3] Memory Controller, Semiconductor Memory System and Operating Method Thereof, "Application Number : 15/599,576, Application Date : 2017-05-19, Patent Numer : US 10,200,063, Issue Date : 2019-02-05"</p> | | |

Computer Division



| | |
|--|---|
| <h2>Computer Systems and Network Lab</h2> | <p>■ Contact information Professor : John Dongjun Kim TEL : 042-350-3535 Lab. : N1-518 TEL : 042-350-7735 Website : http://icn.kaist.ac.kr/~jjk12/</p> |
| <p>■ Current state of the Lab. (in 2019 Fall Semester) Postdoctoral Fellows : 0 PhD Students: 4 Master's Student: 10</p> | |
| <p>■ Research Areas</p> <ul style="list-style-type: none"> ● Computer and System Architecture for Deep Learning <ul style="list-style-type: none"> - Scale-out interconnection networks for machine learning - Efficient communication-centric architecture for accelerators ● Memory-centric Network Architecture <ul style="list-style-type: none"> - Memory-centric network architecture for machine learning - Scalable near-data processing architectures ● Architecture and Security <ul style="list-style-type: none"> - Side-channel attacks in modern processors - Architectural vulnerability in interconnect ● Mobile System for Continuous Monitoring and Intervention <ul style="list-style-type: none"> - Monitoring Itching condition - Language Development <div style="display: flex; justify-content: space-around; align-items: center;"> <div data-bbox="821 392 1093 616"> <p style="text-align: center;">Scalable Memory-Centric Architecture</p> </div> <div data-bbox="1141 392 1460 616"> <p style="text-align: center;">Pikit [Usenix Sec'16]</p> </div> </div> <div style="display: flex; justify-content: space-around; align-items: center;"> <div data-bbox="821 638 1093 896"> <p style="text-align: center;">Itchtector [CHI'16]</p> </div> <div data-bbox="1141 638 1460 896"> <p style="text-align: center;">TalkBetter [CSCW'14]</p> </div> </div> | |
| <p>■ Recommended courses & Career after graduation</p> <p>Courses recommended include topics related to computer architecture, system programming, distributed systems, and operating systems. Students in the lab have participated in internship at Samsung, Nvidia, and start-up and after graduation, students have joined Samsung Research, Arm Inc, as well as research positions at National Research Labs and at universities. Some students have done their own start-ups as well.</p> | <p>■ Introduction to other activities besides research</p> <p>The lab provides a very open environment where you are encouraged to freely discuss with the professor and other students. We encourage collaboration with other professors in the department, within KAIST, as well as other institutions. We also actively collaborate with industry as well. We also encourage extracurricular activities to provide the best environment.</p> <div style="display: flex; justify-content: center; gap: 20px;">    </div> |
| <p>■ Introduction to the Lab.</p> <p>The Computer Systems and Network Lab is led by Prof. John Kim at KAIST. Prof. John Kim graduated from Stanford University and was part of School of Computing at KAIST before joining School of Electrical Engineering. He has worked on the design of several microprocessors in the industry (Intel, Motorola) and has worked on the design of interconnect at Cray Inc. Currently, the lab addresses the system and architectural design challenges in high performance computing as well as mobile systems. All research in the lab target publications in top-tier conferences in systems and architecture.</p> | |
| <p>■ Recent research achievements ('17~'19)</p> <ul style="list-style-type: none"> - MICRO'18 "Multi-dimensional Parallel Training of Winograd Layer on Memory-Centric Architecture" - ISCA'18 "TCEP: Traffic Consolidation for Energy-Proportional High-Radix Networks" - ASPLOS'17 "History-based Arbitration for Fairness in Processor-Interconnect of NUMA Servers" - ISCA'17 "Footprint: Regulating Routing Adaptiveness in Networks-on-Chip" - ISCA'19 "MGPUsim: Enabling Multi-GPU Performance Modeling and Optimization" | |

| | |
|---|---|
| <p align="center">SMart and MobILE Systems (SMILE) Lab</p> | <p>■ Contact information Professor : Song Min Kim E-mail : songmin@kaist.ac.kr Lab : N26 110 Website : https://sites.google.com/view/smilelab</p> |
| <p>■ Current state of the Lab. (in 2019 Fall Semester) Postdoctoral Fellows : 0 PhD Students: 2 (in US) Master's Student: 2</p> | |
| <p>■ Research Areas</p> <p>5G heterogeneous wireless: The number of wireless devices is anticipated to grow as large as 20 billion by 2020, with emerging technologies ranging from wearable gadgets to smart buildings. This research is to integrate and enable collaboration among billions of deployed devices, in the aim to explore the full capacity behind highly crowded and heterogeneous devices and to reach ubiquitous computing.</p> <p>Internet of Things (IoT) and mobile systems: The emerging paradigm of IoT envisions improving the quality of our lives through pervasively deployed objects. The key features of such objects are low cost, low-energy, and small form-factor, where they are inherently low-end devices. This research pillar focuses on maximizing their capabilities in communication, sensing, and data processing under the limited resources, to realize advanced and practical IoT services.</p> <p>Intelligent radio: Massive yet incompatible wireless technologies suffer from a critical side effect of spectrum inefficiency; a naturally limited resource and a bottleneck to high speed networking. We tackle this with unique flexible and intelligent radio techniques that run on commodity devices, to bring practical, immediate, and broad impact to everyday systems and services.</p> |  |
| <p>■ Recommended courses & Career after graduation</p> <p>Computer networks, network programming, system programming, probability theory, wireless communication, and signal processing. You will have both top quality publications and rich experience in system implementation, offering freedom in career path: From academia and research labs to industry.</p> | <p>■ Introduction to other activities besides research</p> <p>International trips to top conferences, frequent get-together parties, and more. Any new suggestions are welcome. We are open to all kinds of new and fun activities! We value the relationship among members. As an academic family, we should be the strongest supporter for each other throughout the career.</p> |
| <p>■ Introduction to the Lab.</p> <p>We are recruiting in the areas of (i) wireless networks (ii) digital communication (iii) RF systems (iv) embedded systems! Please contact us if you are passionate in one or more of these areas.</p> <p>Our research is about innovation and practicality. We enjoy creative and interesting designs and seeing it work in practice through hands-on implementation on everyday devices, such as smartphones and wearables. Our ideas lie in the intersection of networking, communications, and signal processing. We share our excitement with the world by publishing in top conferences. Prof. Song Min Kim has been with the Computer Science at George Mason University, USA, for two years and is joining KAIST EE in Spring 2019. SMILE lab is looking for enthusiastic students to join our journey! If interested, please do not hesitate to contact Prof. Kim at songmin@kaist.ac.kr</p> | |
| <p>■ Recent research achievements ('17~'19)</p> <p>Eight top conference and six premier journal papers from '17: MobiCom(1), SenSys(2), MobiSys(1), ICDCS(1), INFOCOM(2), USENIX Security(1), TON(3), TCOMM(1), TMC(1), TOSN(1). Both of the two current students (in US) have published top conference papers within the first 18 months after joining. One of them has won the best paper award from the prestigious conference of ICDCS'18 (1/378). For details and videos please visit https://sites.google.com/view/smilelab</p> | |

| | |
|---|---|
| <h1>System Security Lab (SysSec)</h1> | <p>■ Contact information Professor : #202 CHiPs (N26) TEL : 042-350-7430 Lab. : #202 CHiPs (N26) TEL : 042-350-7530 Website : http://syssec.kaist.ac.kr</p> |
| <p>■ Current state of the Lab. (in 2017 Fall Semester) Postdoctoral Fellows : 0 PhD Students: 13 Master's Student: 13</p> | |
| <p>■ Research Areas</p> <p>- Internet of Things (IoT), Embedded System, Cyber Physical System Security Conventional IoT devices, embedded systems, and cyber physics systems have been increasingly connected to the Internet with the development of wireless communication in recent years. These existing systems are very vulnerable because security is not considered seriously from the design stage, so new security problems are emerging 3 or 4 times a week. Their security vulnerabilities are emerging not only in software but also in wireless communications and hardware, such as electromagnetic waves, digital circuits, and sensors. For example, we showed that using a sound for a MEMS gyroscope mounted on a drones could make the drone crash if it is affected by a resonance effect. This research area covers new, various, and comprehensive security issues that have not been addressed physically, based on electronic technologies, including computer-based hacking.</p> <p>- Mobile communication network security research Recently, the biggest security issue in Korea has been the Distributed Denial of Service (DDoS), which means that a certain number of zombie computers are used to disable a specific network. An attack that can cause a bigger wave in society is an attack that neutralizes the entire network. In this research area, new attack methods for various kinds of networks (Internet, 3G / 4G mobile communication, IPTV, etc.) are studied and the network design is designed to be safe against such attacks. In recent years, research on the attack technology of mobile communication core network and network access devices has been intensively studied. As a result of the research in 2015, it has been found that by utilizing the vulnerability of LTE voice call technology (VoLTE) And LTE network denial of service attacks.</p> <p>- Study on vulnerability of domestic cyber infrastructure through simulated attack In order to improve the security of domestic cyber infrastructure, we have been analyzing the weaknesses of our products at the request of the company, analyzing the weaknesses of the cyber infrastructures by request of the government agencies, and working on software/hardware analysis of what we are interested or potentially vulnerable. We so far have identified security vulnerabilities in mobile messengers for smartphones with more than 100 million users, various Fintech apps, and USIM-certified apps, and reported them to developers. In addition to these, vulnerability analysis for various embedded devices such as smart home appliances, CCTV, network switches, and access points is also under way.</p> <p>- Blockchain and Cryptocurrency Even though the blockchain is one of the most popular technology in recent years, most parts of the technology are still being researched at an early stage. Many white papers are being published in the industry to achieve the blockchain consensus for better scalability and security. In platform blockchains like Ethereum, various applications and scalability solutions using smart contracts are being developed. We are interested in blockchain security in consensus algorithms, smart contracts, and others. In 2017, we published a blockchain paper in top security conference for the first time in Korea.</p> | |
| <p>■ Recommended courses & Career after graduation Recommended courses include information protection, security aggression, communication and network-related subjects. Graduates are currently working for the academia (Professors of Kansas State, Oklahoma State, Liberty Univ, Univ. Of Buffalo), research institute (Verisign research, Microsoft research), companies (VMWare, LimeWire, AccelOps, MITER, Symantec, SDS, IBM, NAVER, LG Electronics), government agencies (KISA), and start-ups (Looxid Labs, Theori).</p> | <p>■ Introduction to other activities besides research One overseas business trip per each member every years on average. Frequent (un)official get-together's.</p> |
| <p>■ Introduction to the Lab. Professor Yongdae Kim had taught at the University of Minnesota in the United States for 10 years and has been teaching at KAIST since 2012. In addition to Electrical and Electronics Engineering department, he is also a professor at the Graduate School of Information Security. Students are both from the School of Electrical and Electronics Engineering and the Graduate School of Information Security. As of now (Sep. 2019), the total number of research staff is 26.</p> | |
| <p>■ Recent research achievements ('18~'19)</p> <ul style="list-style-type: none"> - Tractor Beam: Safe-hijacking of Consumer Drones with Adaptive GPS Spoofing, ACM Transactions on Privacy and Security 19 - Bitcoin vs. Bitcoin Cash: Coexistence or Downfall of Bitcoin Cash?, IEEE S&P 19 - Touching the Untouchables: Dynamic Security Analysis of the LTE Control Plane, IEEE S&P 19 - Peeking over the Cellular Walled Gardens - A Method for Closed Network Diagnosis, IEEE Transactions on Mobile Computing 18 - GyrosFinger: Fingerprinting Drones for Location Tracking based on the Outputs of MEMS Gyroscopes, ACM Transactions on Privacy and Security 18 | |

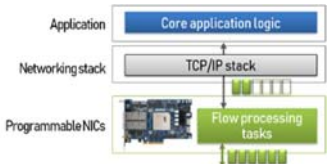
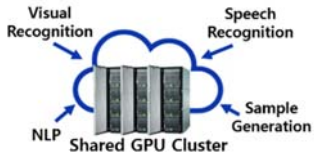
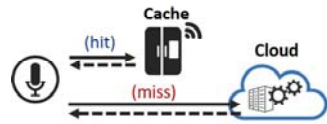
| | |
|--|--|
|  <p>Networked and Distributed Computing Systems Lab</p> | <p>■ Contact Info Prof: ITC Building (N1-813) TEL: (+82) 042-350-7412 Lab: ITC Building (N1-820) TEL: (+82) 042-350-7512 Homepage: https://www.ndsl.kaist.edu</p> |
| <p>■ Lab Members (2019 Fall) Ph.D: 4 M.S.: 4</p> | |
| <p>■ Research Field We conduct research on systems design that fundamentally improves the performance, security, availability, and reliability of networked computing systems, and we prove the effectiveness of new proposals through real-world system implementation and evaluation. Popular IT companies such as Google, Amazon, and Facebook, invest an enormous budget to develop networked and distributed system technologies for ultra-high availability and high performance. The importance of a technological breakthrough grows with the recent advent of low-latency services or high-computing applications such as AR/VR and distributed deep learning. We deal with various problems that occur when the applications operate in data centers, cloud environments or mobile networks, and we propose new systems that are unconventional, while taking advantage of new hardware such as GPUs or SmartNICs.</p> | |
| <p>■ On-going Research Projects (2019) AcceNIC: Accelerating Network Application via SmartNIC In the face of exploding network traffic, such as in data centers, existing network stacks are already showing their performance limitations. To address this problem, this research project focuses on offloading repetitive operations in the transport layer (TCP/IP) and in data encryption (SSL) to a programmable network card (SmartNIC) that can flexibly provide new features.</p>  | |
| <p>CoDDL: GPU Cluster Management System for High Performance Distributed Deep Learning Distributed deep learning, which utilizes multiple GPUs, is widely used to reduce learning time, whereas a single GPU can require several months. Thus, efficient GPU resource allocation and management for multiple tenants is a critical issue in deep learning clusters with many GPUs. We are working on an efficient resource allocator and a scheduler system with consideration of deep learning model characteristics.</p>  | |
| <p>Knowledge Caching: Low Latency Deep Learning Services with Deep Model Cache Deep learning applications offer services that are closely related to our lives in the form of smart speakers. These applications are typically deployed in the cloud servers, but this approach has potential problems such as server computation limits and user information privacy. We propose and implement a system with a new approach, called a deep model cache, which handles user requests that often involve repetitive or sensitive personal information in the local environment.</p>  | |
| <p>■ Recommended course and graduate career It is helpful to take computer science courses that provide background knowledge of system software such as Computer Networks, Operating Systems, Computer Architecture, and System Programming. Alumni of NDSL are working for IT companies such as SKT, Kakao, and NHN, including Google, Intel, and Cisco Meraki. Additionally, one graduate recently started as an assistant professor at the Max Planck Institute (MPI) in Germany.</p> | <p>■ Other Activities In this lab, we encourage Ph.D. students to have internships at leading companies and research institutes (Intel, Microsoft Research, UC Berkeley / ICSI) for exchange with various academic people in the similar research fields. We also have fun together through regular workshops and ski trips.</p> |
| <p>■ Lab Introduction We value quality rather than quantity of research achievements and encourage to lead practical changes. We actively conduct internationally influential researches, which are released as open source and have been followed up by academics (e.g., CCP [SIGCOMM'18], Microboxes [SIGCOMM'18]), or by industry (Intel and Alibaba).</p> | |
| <p>■ Recent Publications (2014 -) Most of the projects in the lab have been published in top-tier conference and some have been honored by awards.</p> <ol style="list-style-type: none"> [1] AcceTCP: Accelerating Network Applications with Stateful TCP Offloading [NSDI '20] [2] mOS: A Reusable Networking Stack for Flow Monitoring Middleboxes [NSDI '17] (Best Paper Award) [3] APUNet: Revitalizing GPU as Packet Processing Accelerator [NSDI '17] [4] FloSIS: A Highly Scalable Network Flow Capture System for Fast Retrieval and Storage Efficiency [ATC '15] [5] Practicalizing Delay-Tolerant Mobile Apps with Cedros [MobiSys '15, IEEE ToN] [6] Gaining Control of Cellular Traffic Accounting by Spurious TCP Retransmission [NDSS '14] [7] mTCP: a Highly Scalable User-level TCP Stack for Multicore Systems [NSDI '14] (Community Award) | |

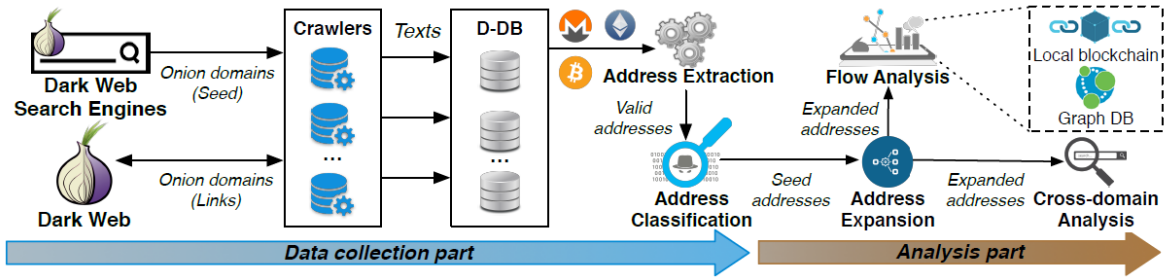
| | |
|---|---|
|  | <p>■ Contact information Professor : ITC Building (N1-910) TEL : 042-350-8323 Lab. : ITC Building (N1-919) TEL : 042-350-7538 Website : http://nss.kaist.ac.kr</p> |
| <p>■ Current state of the Lab. (in 2019 Fall Semester) PhD Students: 9 Master's Student: 7</p> | |
| <p>■ Research Areas</p> <p>- Analysis of the Dark Web Environment The goal of this project is to analyze the Dark Web Environment and learn about the ambiguous environment. In the recent years, the Dark Web has been getting attention by not only the security community, but the general public as well. As the world becomes heavily weighted on the Internet, cyber threats have become a more public issue, causing the surfacing of the Dark Web. The Dark Web is an anonymity guaranteed environment, therefore is a major source of malicious content. By understanding the Dark Web content, structure, mechanism, etc., we can prepare and alleviate the dangers and threats the Dark Web may propose.</p> <p>- Investigation of Cryptocurrency Abuses in the Dark Web The purpose of this research is to collect large scale Dark Web data, extract cryptocurrency information from the Dark Web, and analyze the usages patterns of cryptocurrencies on the Dark Web. The Dark Web is known to be a major source of malicious content such as drugs, malwares, and scamming campaigns. Due to the basic characteristics of anonymity, cryptocurrency are commonly used for trade purchases. Researchers noticed this issue and investigated how cryptocurrencies were used in the Dark Web, but on small or out-of-date datas. This work introduces MFSScope, a framework that analyzes the above mentioned aspects on the most up-to-date Dark Web data.</p>  | |
| <p>■ Recommended courses & Career after graduation The recommended courses include computer networks, network programming, operating system, system programming, machine learning. It is suggested to take a job in a global IT company, a research institute or prestigious university and we actively support to have an international internship during a vacation.</p> | <p>■ Introduction to other activities besides research We aim for stress-free life and studies can be done with no bounds on time and place. Thus, every laboratory members spend their time freely anywhere they want including a lounge and cafe and are encouraged to enjoy club activities as well. The policy to maintain a laboratory is made by reflecting individual opinion.</p> |
| <p>■ Introduction to the Lab. The laboratory members are suggested to read their research project and to submit a paper to a conference or journal even a master's degree student. Furthermore, we provide various research facilities generously. Now, we collaborate with SRI International for several on-going projects.</p> | |
| <p>■ Recent research achievements ('17~'19)</p> <p>[1] Changhoon Yoon, Kwanwoo Kim, Yongdae Kim, Seungwon Shin, Soel Son, "Doppelgängers on the Dark Web: A Large-scale Assessment on Phishing Hidden Web Services", The Web conference, San Francisco, CA, USA, May, 2019 [2] Seunghyeon Lee, Changhoon Yoon, Heedo Kang, Yeonkeun Kim, Yongdae Kim, Dongsu Han, Soel Son, Seungwon Shin, "Cybercriminal Minds: An investigative study of cryptocurrency abuses in the Dark Web", Network & Distributed System Security Symposium, San Diego, CA, USA, February, 2019 [3] Jaehyun Nam, Hyeonseong Jo, Yeonkeun Kim, Phillip Porras, Vinod Yegneswaran, Seungwon Shin, "Barista: An Event-centric NOS Composition Framework for Software-Defined Networks", IEEE Conference on Computer Communications, Honolulu, HI, USA, Apr., 2018</p> | |

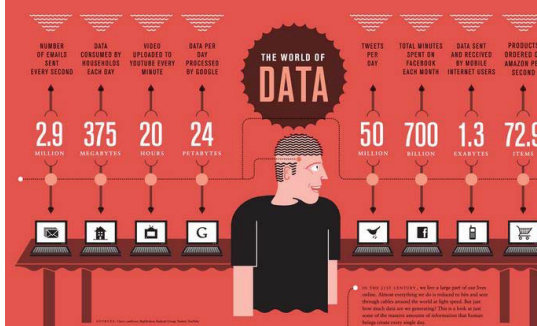
| | |
|---|---|
| <p>Algorithmic Intelligence Laboratory</p> | <p>■ Contact information Professor : Jinwoo Shin TEL : 042-350-7432 Lab. : N1-914 Website : alinlab.kaist.ac.kr</p> |
| <p>■ Current state of the Lab. (in 2019 Fall Semester) Postdoctoral Fellows : 1 PhD Students: 11 Master's Student: 5</p> | |
| <p>■ Research Areas</p> <p>■ Machine Learning and Algorithms</p> <ul style="list-style-type: none"> - Deep Learning - Statistical Inference - Reinforcement and Online Learning - Computer Vision - Large-scale Optimization and Computation - Theoretical Computer Science <p>Development of Social Networking Service and increase of mobile device has lead to a 'big data era', where a massive amount of data is generated at every moment we live. Our laboratory aims to analyze and anticipate such massive amount of data by machine learning or deep learning. We choose to focus on using a more fundamental and mathematical theories in order to carry out our research. In addition we are developing various applications based on our research, which includes using image, video, voice and Social Netowrking Service data.</p> <p>Our laboratory's goal is to produce a researcher with outstanding and confident skills. We emphasize on basic qualifications that researchers should have, and machine learning researches based on such qualifications.</p> |  |
| <p>■ Recommended courses & Career after graduation</p> <p>Our research lies in an intersection of applied mathematics and computer science. We recommend to take (Electronic Engineering) machine learning, data structure, algorithms, statistical inference, information theory, signal processing, (Math) linear algebra, analysis, probability theory.</p> <p>Due to coverage on research in our laboratory, students have high freedom on choosing career after graduation. Each students are able to choose career in industry, school, or even startups depending on their will and research areas.</p> | <p>■ Introduction to other activities besides research</p> <p>Our laboratory highly encourage students to participate in activities that are not related to research. We regularly have sport activities, including soccer, pocket ball and basket ball. There is also friendly match between other laboratories too. Even without the sports, we plan to encourage whatever activity that is beneficial to social life in the laboratory.</p> |
| <p>■ Introduction to the Lab.</p> <p>Any question related to laboratory is welcomed for email at jinwoos@kaist.ac.kr. Our laboratory focus on letting students do what they are best at, and what they like. We hope to make a laboratory where students lead the change, not the professor. Any students in the field of Electronic Engineering, Computer Science and Mathematics who are enthusiastic for world-level research that includes both mathematical theory and system development are welcome.</p> | |
| <p>■ Recent research achievements ('16~'18)</p> <p>In 2015, Prof. Jinwoo Shin has received the ACM Rising Star Award. Moreover he is the first person to receive the Bloomberg Scientific Research Award, given by the world-famous economic news company. He also received the KAIST Technology Innovation Award. He and Sungsoo Ahn (a student in our lab) had the chance to do spotlight presentation (in 2015) and oral presentation (in 2016) in the top class machine learning conference, NIPS (first in Korea). In 2017, our papers are accepted in top machine learning conferences, ICML, NIPS, AISTATS, and top mathematics journals, SIAM Journal on Discrete Mathematics / Scientific Computing.</p> | |

| | |
|--|--|
| <h1 style="text-align: center;">USRG</h1> <p style="text-align: center;">Unmanned Systems Research Group (USRG)</p> | <p>■ Contact information</p> <p>Professor : D. Hyunchul Shim TEL : 042-350-7445 Lab. : E4 C304 (KI building) TEL : Website : http://unmanned.kaist.ac.kr , Youtube: usrgtube</p> |
| <p>■ Current state of the Lab. (in 2018 Fall Semester)</p> <p>Postdoctoral Fellows : 0 PhD Students: 8 Master's Student: 13</p> | |
| <p>■ Research Areas</p> <p>Our lab aims to deliver breakthrough technologies for unmanned systems such as drones and self-driving cars. By combining principles in electrical engineering, mechanical engineering, and aerospace, we endeavor to develop solutions that can work in real-world environment. Based on our lab's in-house technologies such as flight control systems, autonomous driving solutions, and universal methods for highly autonomous vehicles by humanoids robots.</p>  | |
| <p>Lab Resources</p> | |
|  | |
| <p>■ Recommended courses & Career after graduation</p> <ul style="list-style-type: none"> - Government-subsidised Research Institutes e.g. ETRI, KARI, ADD - Private companies (LG, Naver, Hyundai Motor Company, etc) - Foreign studies for academia (MIT, etc) | <p>■ Introduction to other activities besides research</p> <ul style="list-style-type: none"> - Vigorous participations in various robotics competitions such as AI Grand Challenge(1st place), Hyundai Motor Autonomous Car Challenge(3rd place), DARPA Subterranean Challenge(2nd place, Phase I), Lockheed Martin Autonomous Drone Racing, and MBZIRC 2020. |
| <p>■ Introduction to the Lab.</p> <p>Our lab is recognized as a top-tier research laboratory in drone and autonomous car research. We have sufficient research equipment encompassing various drones, full-size autonomous aircraft, We welcome students who desire to perform revolutionary breakthrough research by combining principles and practices.</p> | |
| <p>■ Recent research achievements ('17~'19)</p> <ul style="list-style-type: none"> - 21 International journal papers, 15 International conference papers, 7 domestic journals, and 47 domestic conference papers - 1st place, AI Grand Challenge, Minister of Science and ICT (2019) - Accolade by Minister of Land, Infrastructure, and Transportation (2018) - Top Prize for Airbus Indoor Drone Racing (2017), IROS Autonomous Drone Racing (2nd place, 2018) | |

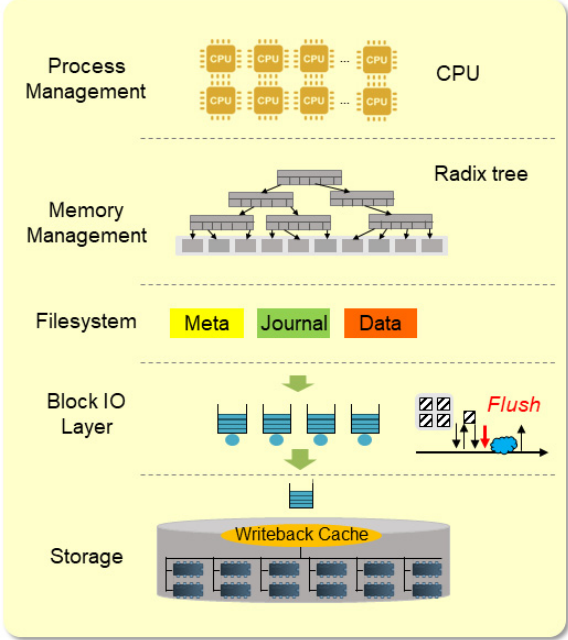
| | |
|---|---|
|  | <p>■ Contact information</p> <p>Professor : Youjip Won TEL : 042-350-7456 Lab. : N26 #210 TEL : 042-350-7456 Website : https://oslab.kaist.ac.kr</p> |
| <p>■ Current state of the Lab. (in 2019 Fall Semester)</p> <p>PhD Students: 6 Master's Student: 8</p> | |
| <p>■ Research Areas</p> <p>We innovate the way to run the computing platforms faster, quicker and with less energy. We deal with wide variety of different computing platforms ranging from the smartphones to the HPC server with hundreds of CPU cores. We investigate the OS issue in the smart watch. Our work majorly involves the deep understanding on the internals of the modern Operating Systems. Followings are the list of the topics we have actively engaged in doing research. Please refer to the publication list at our website to understand what we are doing.</p> <ul style="list-style-type: none"> • Filesystem design for Flash Storage • Software support for NVRAM • Manycore Scalability for modern big data application • Machine Learning runtime • Systems support for Block Chain Applications |  |
| <p>■ Recommended courses & Career after graduation</p> <ul style="list-style-type: none"> • Operating Systems, System Programming, C/C++/Java programming • Samsung Electronics, LG Electronics, Professor at Gyeongsang National University and post-doctoral programs at Texas A&M Univ. | <p>■ Introduction to other activities besides research</p> <p>We go on vacation in Summer individually and go skiing in Winter all together. We have a get-together once a month. We encourage members to do several sport activities like running, swimming and football.</p> |
| <p>■ Introduction to the Lab.</p> <p>The OSLab has published a number of open source tools which are widely used to perform in-depth study for Android smartphone. They include MOST, Mobibench, Mobigen and etc. These tools are used by the industry as well as by the academia from various parts of the world. These tools makes it extremely easy to acquire detailed knowledge in Android IO subsystem. We have developed novel persistent heap layer, HEAPO, which successfully eliminates the heavy filesystem overhead in managing NVRAM. We developed a transactional block device driver, NVRAMDISK, for NVRAM which provides fail-safe atomicity. If you are avid kernel developer and system hacker, join us and participate in advancing the state of art! If you want to be an excellent developer, but do not know where to start, no problem. Just get motivated! Our grad school has a strong program to train you as an independent and competitive system developer.</p> | |
| <p>■ Recent research achievements ('17~'19)</p> <ul style="list-style-type: none"> • Recent work on IO stack design on the Flash Storage proposes a new way of designing the filesystem, block layer and device firmware for the Flash storage ("Barrier Enabled IO Stack for Flash Storage", USENIX FAST 2018, best paper award). • Internetal journals: 3, International conferences: 17, Domestic journals: 3, Domestic conferences: 10 | |

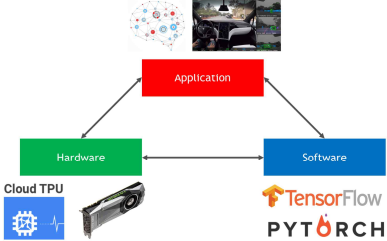
| | |
|---|--|
|  <p>Vertically Integrated Architecture (VIA) Research Group</p> | <p>■ Contact information</p> <p>Professor : Bldg. N1, #809 TEL : 042-350-7447 Lab. : Bldg. N1, #818 Website : https://sites.google.com/view/kaist-via</p> |
| <p>■ Current state of the Lab. (in 2019 Fall Semester)</p> <p>Postdoctoral Fellows : 0 PhD Students: 2 Master's Student: 5</p> | |
| <p>■ Research Areas</p> <p>Vertically Integrated Architecture (VIA) research group conducts research in the domain of computer architecture with a vertically integrated approach. By co-optimizing VLSI circuit technology, computer system architecture, and application & algorithms (with an emphasis on machine learning and computer vision), our research mission is to build high-performance computing platform for future "intelligent" systems that are programmable, robust, reliable, secure, and energy-efficient.</p> |  |
| <p>■ Recommended courses & Career after graduation</p> <ul style="list-style-type: none"> - Courses: computer architecture, data structures, system programming, digital logic design, compilers, operating systems, computer networks - Careers: During your graduate studies, we strongly encourage you to take internships in the industry (preferably in bleeding-edge IT companies like Google, Facebook, NVIDIA, Samsung, Microsoft, and Intel) so that you get practical, hands-on experience within the electrical and computer engineering discipline. | <p>■ Introduction to other activities besides research</p> <p>Professor Rhu is a huge sports fan and encourages students to engage in extra-curricular activities as means to pursue a (mentally & physically) healthy graduate school life. We also encourage lab members to get together outside of the laboratory so that they maintain good social relationships with each other. There are frequent (un)official get-togethers and we plan on having regular team-building events during summer & winter breaks.</p> |
| <p>■ Introduction to the Lab.</p> <p>Professor Minsoo Rhu has spent three years working at NVIDIA Research as a Senior Research Scientist. He worked in several domains within the computer system stack, including ASIC designs, computer system architecture, runtime systems, and application & workload characterization with an emphasis on machine learning (ML) and computer vision (CV). As such, our research mission is to train students to become computer system architects that understands <i>both</i> the hardware and software system, enabling you to optimize any target application (e.g., ML or CV) for the underlying computing stack. Our group is currently funded by several <i>research-oriented</i> projects, for instance, the ERC-AI (by National Research Foundation), Neural Processor Research Center (by Samsung Research), Samsung Future Research Funding and Incubation Center for Future Technology, and others.</p> | |
| <p>■ Recent research achievements ('16~'19)</p> <p>[1] Youngeun Kwon, Yunjae Lee, and Minsoo Rhu, "TensorDIMM: A Practical Near-Memory Processing Architecture for Embeddings and Tensor Operations in Deep Learning," The 52nd IEEE/ACM International Symposium on Microarchitecture (MICRO-52), Columbus, OH, Oct. 2019</p> <p>[2] Youngeun Kwon and Minsoo Rhu, "A Disaggregated Memory System for Deep Learning," IEEE Micro, Special Issue on Machine Learning Acceleration, Sep./Oct. 2019</p> <p>[3] Youngeun Kwon and Minsoo Rhu, "Beyond the Memory Wall: A Case for Memory-centric HPC System for Deep Learning", The 51st IEEE/ACM International Symposium on Microarchitecture (MICRO-51), Oct. 2018</p> <p>[4] Minsoo Rhu, Mike O'Connor, Niladrish Chatterjee, Jeff Pool, Youngeun Kwon, and Stephen W. Keckler, "Compressing DMA Engine: Leveraging Activation Sparsity for Training Deep Neural Networks", The 24th IEEE International Symposium on High-Performance Computer Architecture (HPCA-24), Feb. 2018</p> <p>[5] Angshuman Parashar, Minsoo Rhu, Anurag Mukkara, Antonio Puglielli, Rangharajan Venkatesan, Brucec Khailnay, Joel Emer, Stephen W. Keckler, and William J. Dally, "SCNN: An Accelerator for Compressed-sparse Convolutional Neural Networks", The 44th IEEE/ACM International Symposium on Computer Architecture (ISCA-44), Jun. 2017</p> <p>[6] Minsoo Rhu, Natalia Gimelshein, Jason Clemons, Arslan Zulfiqar, and Stephen W. Keckler, "vDNN: Virtualized Deep Neural Networks for Scalable, Memory-Efficient Neural Network Design", The 49th IEEE/ACM International Symposium on Microarchitecture (MICRO-49), Oct. 2016</p> | |

| | | |
|---|--|--------------------|
|  | Contact Information | |
| | Professor : E3-2 3205 | TEL : 042-350-3495 |
| | Lab : E3-2 3204, 3206, 3211 | TEL : 042-350-7261 |
| | Homepage : http://ncl.kaist.ac.kr | |

Current state of the lab(2019 Fall semester)

Professor: 1 Post Doctorate Fellows : 1 Ph.D students : 12 Master's students: 11 Researcher: 1 Staff: 1

Research Areas

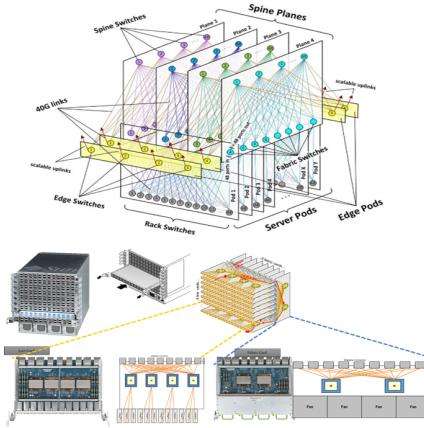

Fig 1. Supercomputing interconnection system



Fig 2. XAI based Energy Platform Development

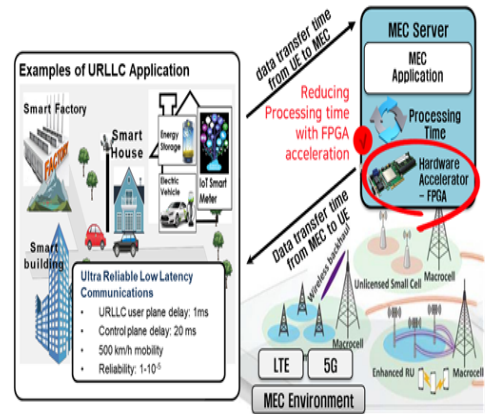

Fig 3. Mobile Edge Computing (MEC) platform technology

1) Supercomputing interconnection system (Refer to Fig 1.)

- Development of an efficient interconnect system for supercomputing.
- High speed on-board router and adaptive routing method development.

2) XAI based Energy Platform Development (Refer to Fig 2.)

- Real-time detection of power patterns that have high probability of failure from real-time data stream monitoring instrument
- Distributed task execution technology for deep-learning-based Complex Event of time series data stream.

3) Edge computing platform (Refer to Fig 3.)

- Develop of the edge server platform supporting a real-time high speed processing for Ultra Reliable Low Latency Communication (URLLC) applications.
- Support various applications including Deep Neural Network, Computer Vision Processing, ... ,etc.

Other Researches in Progress

- ▷ Integrated Deep Learning Engine(IDLE) for supporting various DL frameworks
- ▷ Crowdsourcing based Smart City Service Framework

*Further detail information of research areas are addressed in our homepage

Recent Research Achievements (~'19)

[1]Dong-Ki Kang and Chan-Hyun Youn "Real-time Power Control for Cost Efficient Deep Learning Processing with Renewable Power Generation" to appear in IEEE Access 2019.



[2]Eunju Yang, Dong-Ki Kang, Chan-Hyun Youn "BOA: Batch Orchestration Algorithm for Straggler Mitigation of Distributed DL Training in Heterogeneous GPU Cluster" The Journal of Supercomputing, pp. 1 – 21, Apr. 2019.

[3]S. H. Kim, J. B. You, Y. G. Ha, G. K. Kang, D. S. Lee, H. H. Yoon, D. E. Yoo, D. W. Lee, C. H. Youn and H. H. Park "Thermo-optic control of the longitudinal radiation angle in a silicon-based optical phased array" Optics Letters, Vol. 44, Iss. 2, pp. 411 – 414, Jan. 2019.

[4] Dong-Ki Kang, Eunju Yang, Chan-Hyun Youn "Deep Learning based Sustainable Data Center Energy Cost Minimization with Temporal MACRO/MICRO Scale Management" IEEE Access, Vol. 7, pp. 5477 – 5491, Jan. 2019.

[5]Jae-Ho Jeong, Seong-Hwan Kim, Minsu Jeon, Chan-Hyun Youn "Adaptive Object Re-identification based on RoI aware Sift-CNN Hybrid Feature Clustering" Int'l Conference on Artificial Intelligence (ICAI'19), August 2019.

*Further detail information of publications are presented our homepage

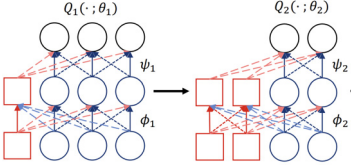
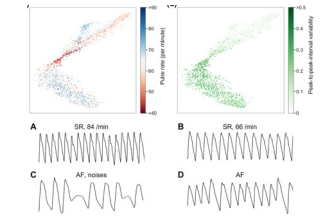
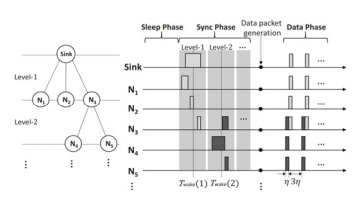
| | |
|--|--|
|  <p>LeArning in Networking: Algorithm, Design, and Analysis</p> | <p>Contact information Professor: #810 N1 TEL: 042-350-3486 Lab.: #819 N1 TEL: 042-350-5486 Website: http://lanada.kaist.ac.kr</p>  |
| <p>Current state of the Lab. (in 2019 Fall Semester) Postdoctoral Fellows : 0 PhD Students: 11 Master's Student: 11</p> | |
| <p>Research Areas We study every "connected" things in the world. We seek harmony between mathematical research (theory) and systematic (real) research, and are always looking for the combination with other research areas. (physics, economics, machine learning) We are actively studying the following areas.</p> <ul style="list-style-type: none"> - Multi-agent RL architectures and algorithms - Large scale neural network optimization - Deep learning for X (medical data, AMI data, networking) - Drone network and applied machine learning in drone network - Next-generation sensor networks and IoT (Internet of Things) | <div style="display: flex; flex-wrap: wrap;"> <div style="width: 50%;">  <p style="text-align: center;"><Communication in MARL></p>  <p style="text-align: center;"><Weight sharing for large scale NN></p> </div> <div style="width: 50%;">  <p style="text-align: center;"><Deep Learning for medical data></p> </div> <div style="width: 50%;">  <p style="text-align: center;"><IoT/Sensor Networks></p> </div> </div> |
| <p>Recommended courses & Career after graduation Computer network, probability and introductory random processes, programming structure for electrical engineering, data structures and algorithms for electrical engineering, basic machine learning and communication engineering are recommended courses. We also encourage you to take basic maths courses that help you to build your mathematical thinking skills. LANADA alumni continue their research in globally prestigious universities as post-docs, or in the industry with the best treatment.</p> | <p>Introduction to other activities besides research We have regular exercise once a week. The purpose of regular exercise is to be healthier and to make harmonious friendship inside the lab. Moreover, we have regular summer and winter MTs, various activities including fishing, skiing & snowboarding, and various leisure to refresh the atmosphere and to make strong fellowship between lab members.</p> |
| <p>Introduction to the Lab. Our laboratory has been seeking 'creativity' and 'freedom' in research. Through free discussion and communication between the professor, seniors and juniors, we encourage our students to find new ideas and solutions to problems and study together. Whenever we want to have discussion with the adviser, we have the opportunity to do so. When a meeting starts, time passes quickly more than 2 or 3 hours. Above all, we help students enjoy their life in laboratory.</p> <p>We are trying our best to globalize our level of research. Without going overseas to study, students who graduate from our laboratory obtain competence at least as much as overseas-educated. We send Ph.D candidate students to leading universities and laboratories around the world including the United States. For more detail, please refer to our website.</p> <p>Also, we encourage domestic or international joint research with world class laboratories.</p> <ul style="list-style-type: none"> - USA: Princeton, U.T. Austin, North Carolina Univ., Arizona State Univ., Alcatel Bell Labs, Los Alamos National Lab, etc. - Europe: King's College London (UK), K.U. Leuven (Belgium), Microsoft Research UK, KTH, (Sweden), NTNU (Norway) - Asia: CUHK, HUST (Hong Kong) | |
| <p>Recent research achievements ('17~'19)</p> <ol style="list-style-type: none"> [1] Present and publish the research result on top tier conferences and journals every year. (e.g., IEEE Transactions on Information Theory, IEEE INFOCOM, ACM Sigmetrics, ICML, ICLR, IJCAI, ICNP) [2] Technical program committee of top tier conferences in network area. (e.g., IEEE INFOCOM, ACM MobiHoc) [3] Best paper award at top conference in network area. (ACM MobiHoc, IEEE SECON) [4] Various awards (Samsung Humantech paper award, Qualcomm fellowship award, etc.) | |



Contact information

Professor : LG Hall 1109 TEL : +82-42-350-7434
 Lab. : LG Hall 1111 TEL : +82-42-350-7534
 Website : http://www.cad4x.kaist.ac.kr

Current state of the Lab. (in 2019 Fall Semester)

Postdoctoral Fellows : 0 PhD Students: 2 Master's Students: 4

Research Areas

CAD4X (Computer-aided design for 'X') stands for systematic design and optimization using computer-aided design of beyond semiconductor circuits and systems including energy systems. CAD4X laboratory has introduced numerous world-first innovative techniques for device- and system-level power/energy measurement/estimation. CAD4X laboratory publishes above-mentioned research at journals, magazines, conferences, symposia and workshops. CAD4X laboratory pursues practically applicable design and optimization techniques, and has demonstrated with working prototypes at ISLPED design contest and Design Automation Conference university Booth.

Embedded Systems

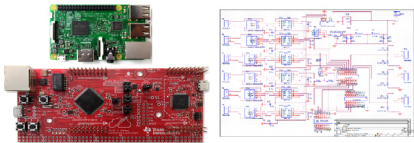

- In order to construct a specific system, e.g. DAQ, controller, etc., we design embedded systems
- Circuit design and prototype implementation
- OrCAD, PSpice, Real-time OS and Microcontrollers

Modeling & Simulation

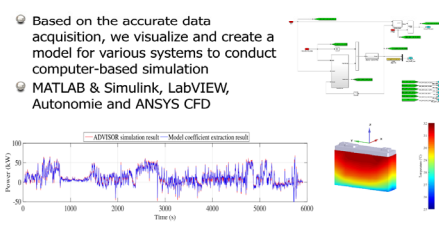

- Based on the accurate data acquisition, we visualize and create a model for various systems to conduct computer-based simulation
- MATLAB & Simulink, LabVIEW, Autonomie and ANSYS CFD

Design & Optimization

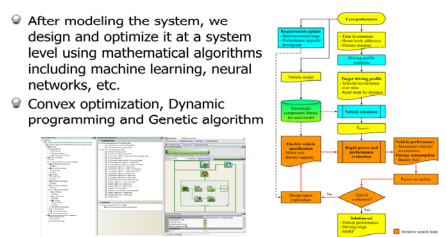

- After modeling the system, we design and optimize it at a system level using mathematical algorithms including machine learning, neural networks, etc.
- Convex optimization, Dynamic programming and Genetic algorithm

Energy Harvesting

Various eco-friendly energy sources

- Photovoltaic cell array reconfiguration
- Thermal energy harvesting
- Storage-less and converter-less maximum power point tracking and SmartPatch

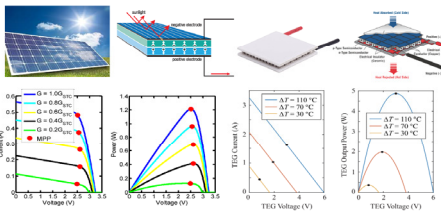

Cyber-Physical Systems

Power-aware cyber-physical systems

- Power and energy optimization
- Cross-layer power-aware design
- Modeling and simulation
- Design and runtime power management

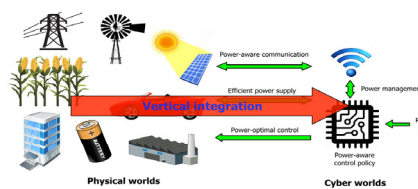

Low-Power Embedded Systems

Accurate power measurement & management

- Power management of computing systems
- Power management of memory and I/O subsystems
- Comparative analysis of power drawn by subsystems (CPU, display, etc.)

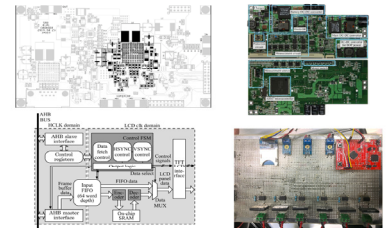

Recommended courses & Career after graduation

- Curriculum: electronic circuits, embedded systems and digital systems
- Career path: professor, researcher in industry, postdoctoral fellows, etc.

Introduction to other activities besides research

Perform project exhibitions at major conferences and have a camping after the conference schedule

Introduction to the Lab.

- CAD4X is recognized as the world-first innovative group by experimental result demonstrations at the world-class conferences.
- Professor Naehyuck Chang is a Fellow of both ACM and IEEE for contribution to low-power systems, and the Editor-in-Chief of the ACM Transactions on Design Automation of Electronics Systems. He served for the ACM SIGDA (Special Interest Group on Design Automation) and is currently Past Chair of ACM SIGDA. He was a TPC Chair of DAC 2016 and ASP-DAC 2016.

Recent research achievements ('16~'19)

- Electric vehicle conversion for the off-road vehicle
- Exhibition at the International Electric Vehicle Expo in Jeju
- Exhibition at the 50th SEMA show in Las Vegas
- Attended jeep jamboree 2017, in USA
- A self-powered and patchable cumulative UV irradiance meter
- Exhibition at the university booth in design automation conference
- Reconfigurable thermoelectric generator
- Prize at university booth in design automation conference
- Prize at ISLPED design contest

| | |
|---|---|
|  <p>Computer Architecture and Memory Systems Laboratory</p> | <p>■ Contact information Professor : Myoungsoo Jung TEL : 042-350-7455 Lab. : N1 421 TEL : 042-350-7555 Website : http://camelab.org</p> |
| <p>■ Current state of the Lab. (in 2019 Fall Semester) Postdoctoral Fellows : 0 PhD Students: 8 Master's Student: 0</p> | |
| <p>■ Research Areas CAMELab is mainly focusing on the well-known performance bottleneck in conventional computer architecture and operating systems: memory and storage. We are officially supported from multiple organizations such as U.S. Department of Energy, U.S. National Science Foundation, and Lawrence Berkeley National Laboratory for our projects. Also, we are spanning our research to novel computing systems for new applications including machine learning and big data analysis. We are also collaborating with many different industries and institutions to address various research problems. Our current interests of research include but not limited as follows.</p> <p>New Memory Systems</p> <ul style="list-style-type: none"> ▪ New memory device design and controller implementation (e.g. Z-NAND, PRAM) ▪ Linux kernel I/O stack revamping to exploit characteristics of fast and byte-addressable storage class memory. <p>Kernel & Storage Architecture</p> <ul style="list-style-type: none"> ▪ High performance SSD architectures and their firmware design considering internal parallelism and resilience system issues ▪ In-memory processing and In-storage processing <p>Storage-Intensive Computing</p> <ul style="list-style-type: none"> ▪ System design for data-centric scientific computations (e.g. Bio-informatics/Graph) ▪ OS-level virtualization and Docker container-based computing/service <p>Heterogeneous Computing</p> <ul style="list-style-type: none"> ▪ NVM-aware RISC-V-based core design ▪ GPGPU architecture/FPGA-based accelerators | |
| <p>■ Recommended courses & Career after graduation We recommend taking courses related to operating systems, system programming, and computer architecture. It would be better to have experiences with simulators or benchmarking tools. About career, based on your will, dr. Jung will support everything for you to get publications and become a leading researcher at from industry to faculty jobs.</p> | <p>■ Introduction to other activities besides research We regard horizontal and active communications as important. We are moving forward together encouraging each other. If you're interested, check out our lab's instagram :-) @camelab_members</p>  <p>  camelab_members</p> |
| <p>■ Introduction to the Lab. Professor Jung has years of experience in LBNL as a guest researcher. Afterward, he has advised his students at UT Dallas, Yonsei Univ., and KAIST. Under support and collaborations with U.S. government organizations, industries(Intel, Western Digital, Sandisk, Samsung, SK Hynix, Memray), and institutions (UIUC, Georgia tech) our lab have published many papers to top-tier conferences. We continue to target top-tier conference publications in a perfect environment for research.</p>  <p>↑ homepage</p> | |
| <p>■ Recent research achievements ('17~'19)</p> <ul style="list-style-type: none"> ▪ 13 publications in top-tier conferences (total 31 publications including major conferences and SCI journals) ▪ 6 international patents, 2 domestic patents | |

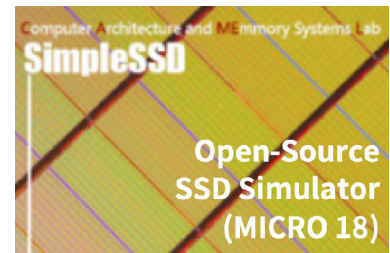

| | |
|--|--|
| Data Science and Network Lab. (DSNL) | <p>■ Contact information</p> <p>Professor : ITC (N1) #913 TEL : 042-350-3473 Lab. : ITC (N1) #918 TEL : 042-350-5473/4445 Website : http://netsys.kaist.ac.kr</p> |
| <p>■ Current state of the Lab. (in 2019 Fall Semester)</p> <p>Postdoctoral Fellows : 0 PhD Students: 6 Master's Student: 3</p> | |
| <p>■ Research Areas</p> <p>Multi-Resource Management with Reinforcement learning</p> <p>Today's networks are made up of a variety of resources, including networking, computing, and sensor information. In addition, various service requirements are becoming increasingly complex, and these service requirements are made up of chains of resources and functions. Based on reinforcement learning, DSNL designs a network model that supports a variety of resources and services instead of simply communicating information.</p> <p>Multi-Modal Reinforcement</p> <p>Most of artificial intelligence has a sequential decision making process, which is often studied through reinforcement learning. DSNL studies reinforcement learning algorithms in a multi-modal environment in which various forms of data are provided in a non-standard format, rather than a standardized simulator or learning from a given data set.</p> <p>Automated AI</p> <p>In the case of machine learning models, it is difficult to construct layer or set hyperparameters without expert knowledge. In this study, we develop algorithms that automatically generate neural networks without human intervention.</p> <p>Internet of Things (IoT)</p> <p>With the emergence of many different IoT devices, traditional wireless networks have evolved into complex forms. With the development of various devices, multiple wireless technologies and protocols, various issues have arisen to support real IoT devices. Among other things, we are working on Fault-tolerance / Resilience networking technology. In particular, we are developing D2D link chaining technology to support interworking between different network technologies, and researching network slicing technology in IoT networks by incorporating Software Defined Networking (SDN) technology.</p> | |
| <p>■ Recommended courses & Career after graduation</p> <p>Probability and Random Process, Communication Engineering, Programming Classes, Computer networks are recommended courses. Graduates usually continue their researches in various leading universities as Posr-Doc, Professors. Some get a position in companies such as Samsung, SKT, ETRI, etc. You can check our alumnus on lab webpage.</p> | <p>■ Introduction to other activities besides research</p> <p>Our laboratory encourage to co-work. Seniors pass on know-how to juniors during co-work. In free atmosphere, we can choose research topic and our study. We have regular summer/winter field trip. Usually to mountain valley in summer and skiing for winter. We also have annual lab home coming day.</p> |
| <p>■ Introduction to the Lab.</p> <p>The Data Science and Network Lab. (DSNL), led by Prof. Song Chong, was established in March 2000 as part of Department of Electrical Engineering and Computer Science at Korea Advanced Institute of Science and Technology (KAIST). Our research interests lie in decision making, human behavior modelling, stochastic optimization, machine learning and multi-agent systems with applications to computer networks, mobile computing, and computational engineering. Prof. Chong is a leading expert in this area as Head of the Graduate School of Artificial Intelligence.</p> | |
| <p>■ Recent research achievements ('17~'19)</p> <p>Published paper in various top tier journals & conferences – IEEE ICC, IEEE WiOpt, IEEE Trans. on Mobile Computing, IEEE Trans. on Wireless Communications, etc.</p> | |

Contact information

Professor:T237, Truth Hall, Munji Campus TEL: +82-42-350-7142
Lab.:T244, Truth Hall, Munji Campus TEL: +82-42-350-5459
Website: http://mnlab.kaist.ac.kr

Current state of the Lab. (in 2019 Fall Semester)

Postdoctoral Fellows : 1 PhD Students: 10 Master's Student: 3

Research Areas

- Study on improving IoT efficiency and data reliability**
 - A sensor testbed for collecting data and applying research
 - Data tagging technology for efficient preprocessing of IoT data
 - Data Loss Recovery Techniques for Improving IoT Data Integrity
 - Data transmission control technology for energy efficiency
- Study on Energy trade / saving / prediction model research**
 - Energy trading system using Game Theory and Optimization Theory
 - EV charging optimization with battery characteristics and degradation
 - Power energy estimation/forecasting model with data analysis and learning
- Study on trust provisioning technology based ICT environment**
 - Data transaction modeling and individual reliability analysis in personal information trading environment
 - Evaluation of an entity's trustworthiness based on Personal Information Protection Law

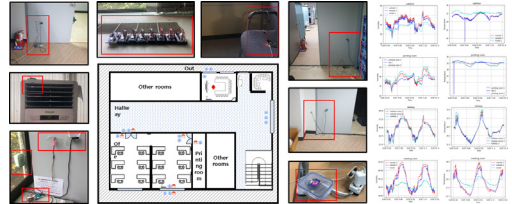

Fig. Sensor Testbed and collected data

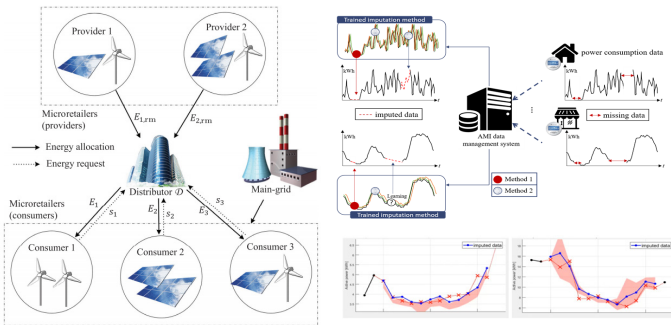

Fig. 1. System model for a contribution-based control of energy allocation in microgrid infrastructures.

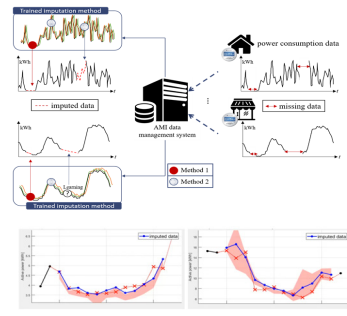

Fig. System model and examples of data interpolation

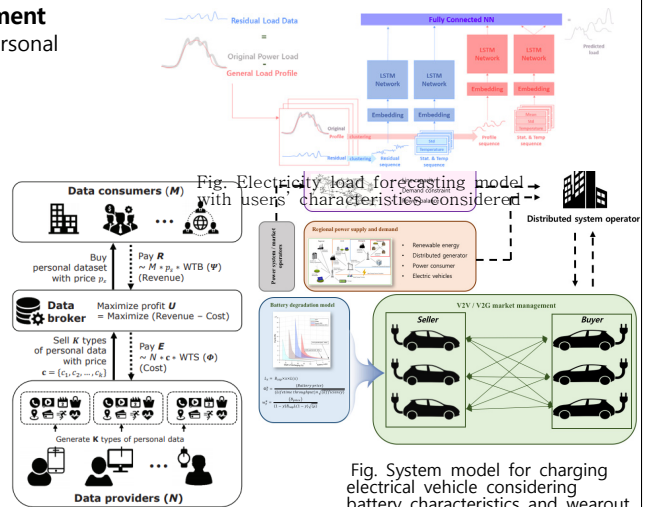

Fig. 1. The proposed personal data trading model with multiple types in the IoT data market

Fig. Electricity load forecasting model with users' characteristics considered

Fig. System model for charging electrical vehicle considering battery characteristics and wearout

Recommended courses & Career after graduation

Mathematical basics such as probability and statistics, optimization theory
Learning subjects such as learning theory and data processing
Communication and Network Basic Courses, including Communication and Information Theory and Introduction to Network

Career after graduation

As of 2019, 15 PhD graduates (Professor, Samsung Electronics, ETRI, etc.) and 45 masters (PhD., Naver, ADD, etc.) have been trained to nurture outstanding talents. Recent graduates' careers are widely distributed in the government-funded research institutes (ETRI, ADD, etc.), large corporations (Samsung Electronics, LG Electronics), and telecommunication companies (SKT, KT, LGU +).

Introduction to other activities besides research

There are many opportunities to attend many meetings other than research purposes, such as attending ITU-T and IETF standardization activities and participating in hackathon events. Each year, students have the opportunity to visit CES, attend conferences, and organize various group events for fellowship in the lab.

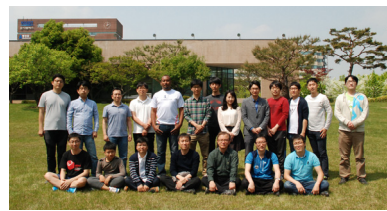

Introduction to the Lab.

Our lab's greatest advantage is the atmosphere of freedom. Once a month, students held a casual meeting to gather our opinions and decide on all kinds of issues of the lab. The professor respects the opinions and rights of the students and actively reflects all matters decided at the student meetings. As various studies are conducted, the desired research topic can be freely selected from related fields in the lab. Our lab regularly held lab seminar to cooperate with each other and share comments on one's research. In addition, some graduates are working as professors in other colleges continuously give help to advise the students in our lab, which is beneficial to get various perspectives of the experts in different fields.

Recent research achievements ('17~'19)

SCI International Journal: 15; International Conference: 14; Domestic Conference: 10
Patent Registration: 35 (International: 9)



| | |
|---|---|
| <h2>Intelligent Network Architecture and Distributed Systems Lab.</h2> | <p>■ Contact information Professor : ITC Building (N1) #814 Lab. : ITC Building (N1) #817 TEL : 042-350-7631 Website : http://ina.kaist.ac.kr/~dongsuh</p> |
| <p>■ Current state of the Lab. (in 2019 Fall Semester) Professor: 1 PhD Students: 6 Master's Student: 4 Undergraduate Students: 2 Staff: 1</p> | |
| <p>■ Research Areas With more diverse applications and its requirements, we design/implement (1) the distributed system where such applications can be operated efficiently, and (2) the new possibility created with more interconnected computers.</p> <p>Cloud infrastructure: Currently, many applications and its infrastructure become more complex with advanced features. This trends will continue as technology advances. Accordingly, we are making network/cloud infrastructure more intelligent.</p> <p>Why cloud and distributed systems?: Cloud and distributed system is the key to realize computer's infinite possibility. You can reflect your vision into the software technology. New systems create new worlds and the new worlds require new systems. For example, big-data processing system becomes the infrastructure extracting "knowledge" from the raw data such as Google Search. Moreover, you can make current systems more efficient. For example, if mobile OS like Android can predict network performance in real time to show the YouTube video, it can reduce the delay to play the video, which create additional market value.</p> <p>■ Recent Research Topics</p> <ul style="list-style-type: none"> - Cloud computing and Big data processing: Resource allocation for cloud infrastructure, optimization with Big Data. - Internet-scale content distribution: Software-defined content distribution, QoE inferencing and optimization, diagnosis. - Software switch/middlebox: Software design for many-core systems, flexible programming framework for network devices. - Future Internet architecture: Evolvable congestion control, evolvable service model, incremental deployment over IP. - Mobile Application Acceleration: Automatic framework for reducing response time of mobile application - Network Security: Automatic protocol fingerprinting, Enhancing security and privacy of network applications using SGX | |
| <p>■ Recommended courses & Career after graduation We recommend you to take Computer Networks, Network Programming, System Programming, Operating System, Data Structure, and Discrete Structure courses.</p> <p>You will have ability to design, implement, and manage the new systems required in the future. You will experience a new world with new software systems and introduce them to the public. You will be a great software architect required by many industries and laboratories predicting and leading the new technology trend.</p> | <p>■ Recommended courses & Career after graduation We want to create a comfortable, open and active laboratory atmosphere, and an environment where we can discuss with professor freely. We will actively encourage and support joint research and internships with researchers. We want to create an environment where different people can create synergy by using individual skills and their own strengths. We will actively support students' self-improvement and exercise/hobby activities, and use a lot of resources for students to create a happy laboratory environment for students</p> |
| <p>■ Research Environment You can start research with fun in our lab. You will learn related knowledge and skills while working on practical project. We also have many research projects collaborating with other laboratories in other countries (US, Europe, Hongkong, etc.). Please refer to the website for the details (http://ina.kaist.ac.kr/~dongsuh). We try to develop experts who can collaborate with other people by developing one's own strength. To do so, we provide trendy research area and great environment to those who are interested in the research on computer systems and networks.</p> | |
| <p>■ Recent research achievements ('16~'19) Prof. Han received his Ph.D. from the Computer Science Department at Carnegie Mellon University in 2012. He designed future Internet architecture, XIA (eXpressive Internet Architecture), getting paid attention internationally, and he published various papers to the best conferences on systems and networks (NSDI, SIGCOMM, Mobisys, etc.). We are looking for the students with CS/EE background who are interested in the top-level research. In addition, we are also working on cloud computing, big data processing systems, software defined networking, software switch/middlebox, many-core system, Internet content delivery.</p> <p>* We have published papers to the top-level conferences including SIGCOMM, OSDI, NSDI, CoNEXT, NDSS, HotNets, etc.</p> | |



| | |
|--|--|
| Data Intelligence Lab | <p>■ Contact information</p> <p>Professor : Steven Euijong Whang TEL : 010-6788-2902 Lab. : N1-516, 519 TEL : 042-350-7443 Website : http://stevenwhang.com</p> |
| <p>■ Current state of the Lab. (in 2019 Fall Semester)</p> <p>Postdoctoral Fellows : 0 PhD Students: 2 Master's Students: 5</p> | |
| <p>■ Research Areas</p> <p>The recent success of AI / Machine Learning is largely due to the availability of Big data and the infrastructure to scale computation. As a result, the integration of AI / Machine Learning and Big data management techniques becomes inevitable. The Data Intelligence lab performs research on this integration in both directions. First, we explore Big data management techniques that are needed throughout a Machine Learning lifecycle. Second, we explore Machine Learning techniques that can improve Big data management. We are funded by Google AI (AI Focused Research Award), the National Research Foundation of Korea (AI ERC), SK Telecom, and the KAIST Institute. Below are current topics of interest.</p> <p>Large-Scale Data Collection and Cleaning: As Deep Learning becomes more prevalent, the bottleneck of Machine Learning shifts from feature engineering to data collection and preparation. We investigate large-scale data labeling techniques that are accurate and resource efficient. We also develop data cleaning techniques for machine learning.</p> <p>Automatic and Actionable Model Analysis: As Machine Learning is democratized, analyzing trained models can be a daunting task for users who do not have expertise in Machine Learning or engineering. We investigate techniques for automatically identifying problematic data slices where models perform poorly and providing concrete action items.</p> <p>Model Fairness and Robustness: The end users of Machine Learning are humans, so it is important that model predictions are fair where they do not discriminate certain demographics of users. In addition, models must be robust against noisy or poisoned data. We develop novel model architectures that optimize on fairness and robustness.</p> | |
| <p>■ Recommended courses & Career after graduation</p> <p>Recommended courses include discrete mathematics, data structures, algorithms, databases, data mining, probability theory, linear algebra, and machine learning.</p> <p>Students will be trained to be world-class researchers and have career opportunities both in academia and industry.</p> | <p>■ Introduction to other activities besides research</p> <p>Students are encouraged to participate in extracurricular activities for a sustainable and enjoyable graduate school life experience. For example, I like swimming and am an alum of KAORI (KAIST swimming team). Our lab also has regular social events.</p> |
| <p>■ Introduction to the Lab.</p> <p>The Data Intelligence Lab solves important problems in Big Data analytics, Big Data systems, and Big Data - Artificial Intelligence integration. If you are passionate about integrating Big Data and AI, please contact me.</p> <p>Prof. Steven Euijong Whang joined the KAIST EE faculty in February 2018. He is a Co-chair of the recent Google-KAIST Partnership. Before that, he was a Research Scientist at Google Research and co-developed the data infrastructure of TensorFlow Extended (TFX). He received his Ph.D. in computer science in 2012 from Stanford University working with Prof. Hector Garcia-Molina and received his B.S. in computer science from KAIST in 2003.</p> | |
| <p>■ Recent research achievements ('17~'19)</p> <ul style="list-style-type: none"> ● Google AI Focused Faculty Research Award (PI, first in Asia, 2018-2019) ● Y. Chung, T. Kraska, N. Polyzotis, K. Tae, S. E. Whang, "Automated Data Slicing for Model Validation: A Big data - AI Integration Approach," In <i>IEEE Transactions on Knowledge and Data Engineering</i>, May 2019. (Corresponding author) ● D. Baylor et al., "TFX: A TensorFlow-Based Production-Scale Machine Learning Platform," In <i>ACM SIGKDD</i>, August, 2017. (Co-corresponding author) | |

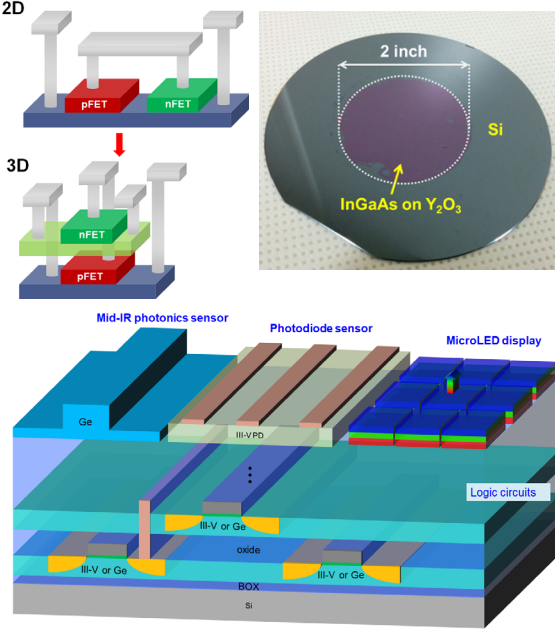

Device Division

| | |
|--|--|
| <p style="text-align: center;">3D integrated opto-electronic device Laboratory</p> | <p>■ Contact information Professor : shkim.ee@kaist.ac.kr TEL : 7452 Lab. : E3-2, 1230 TEL : 7552 Website : https://sites.google.com/site/sanghyeonkim85/</p> |
| <p>■ Current state of the Lab. (in 2019 Fall Semester) Postdoctoral Fellows : 2 PhD Students: 2 Master's Student: 2</p> | |
| <p>■ Research Areas : 3D integrated opto-electronic semiconductor devices (mainly using III-V compound semiconductor and Ge.), which is one of the most promising device research areas toward future 3D integrated systems</p> <ul style="list-style-type: none"> ▶ Monolithic 3D integration Monolithic 3D integration provides increased bandwidth, smaller power consumption, smaller footprint, and increased functionality. We are exploring layer stacking and device technology to realize stackable 3D devices. ▶ Next Generation computing To reduce computing power, we are developing next-generation CMOS devices using III-V, Ge. Recently, we initiated the research on functional devices for neuromorphic computing . ▶ MicroLED display For ultra-small, but ultra-high resolution display, we are developing 3D stacked inorganic MicroLED display. ▶ Mid-IR photonics For sensing application, we are developing Mid-IR photonics platform using SOI, GOI. ▶ Thin film imager We are developing layer stacked thin film image sensor. |  <p>The diagrams show 2D and 3D device structures with pFET and nFET components. A circular inset shows a 2-inch diameter Si wafer with InGaAs on Y₂O₃. A detailed cross-section shows a stack of layers: Ge, III-V or Ge, oxide, III-V or Ge, BOX, and Si. Specific components labeled include Mid-IR photonics sensor, Photodiode sensor, MicroLED display, and Logic circuits.</p> |
| <p>■ Recommended courses & Career after graduation Any courses about semiconductor devices and solid-state physics, semiconductor integration, photonics are recommended. Career path will include academia, major industries in semiconductor and display, etc.</p> | <p>■ Introduction to other activities besides research We are encouraging students to participate in international and domestic conferences and also internship programs for their experiences. We are also planning to have enjoyable dinner and outer activities regularly.</p> |
| <p>■ Introduction to the Lab. Prof. Kim opened the lab in KAIST on Feb. 2019. We are doing multidisciplinary researches on various semiconductor electron and photonic devices with emphasis on monolithic 3D integration. Therefore, we are fully supporting students own research and helping to broaden their research scope.</p> | |
| <p>■ Recent research achievements ('17~'19) : 23 major journal papers including followings.</p> <ul style="list-style-type: none"> - D. -M. Geum, M.-S. Park, J. -Y. Lim, H. -D. Yang, J. D. Song, C. -Z. Kim, E. Yoon, S. -H. Kim*, and W. J. Choi, "Ultra-high-throughput Production of III-V/Si Wafer for Electronic and Photonic Applications", Scientific reports 6, 20610 (2016) - S. -K. Kim, J. -P. Shim, D. -M. Geum, C. Z. Kim, H. -S. Kim, Y. -S. Kim, H. -K. Kang, J. D. Song, S. -J. Choi, D. H. Kim, W. J. Choi, H. -J. Kim, D. M. Kim*, and S. -H. Kim*, "Cost-effective Fabrication of In_{0.53}Ga_{0.47}As-on-Insulator on Si for Monolithic 3D via Novel Epitaxial Lift-Off (ELO) and Donor Wafer Re-use", International Electron Devices Meeting (IEDM), p. 616 (2016) - S. -H. Kim*, S. -K. Kim, J. -P. Shim, D. -M. Geum, G. Ju, H. -S. Kim, H. -J. Lim, H. -R. Lim, J. -H. Han, S. Lee, H. -S. Kim, P. Bidenko, C. -M. Kang, D. -S. Lee, J. -D. Song, W. J. Choi, and H. -J. Kim, "Heterogeneous Integration toward Monolithic 3D Chip enabled by III-V and Ge Materials", IEEE Journal of the Electron Device Society 6, p. 579 (2018) <p>See more in the webpage -----></p>  | |

| | |
|--|---|
| <h1 style="text-align: center;">1st-Principles Nano-Devices Computing Lab</h1> | <p>■ Contact information</p> <p>Professor : N5 #2311 TEL : 042-350-1717 Lab. : N5 #2154A/2148 TEL : 042-350-1757/1777 Website : http://nanocore.kaist.ac.kr</p> |
| <p>■ Current state of the Lab. (in 2019 Fall Semester)</p> <p>Postdoctoral Fellows : 1 PhD Students: 5 Master's Student: 2</p> | |
| <p>■ Research Areas</p> <ul style="list-style-type: none"> • Theory & Computation <ul style="list-style-type: none"> - physics of non-equilibrium open quantum systems - novel 1st-principles & beyond theory for quantum transport & optical excitation simulations - artificial intelligence (AI) & machine learning for 1st-principles and multiscale nano-device simulations <li style="text-align: center;">↓ • Functional Nano-Materials <ul style="list-style-type: none"> - graphene, 2D materials, & heterostructures - quantum dots, nanorods, & nanoplatelets - hybrid halide perovskites, & bio/organic materials <li style="text-align: center;">↓ • Next-Generation Nano-Devices <ul style="list-style-type: none"> - "more Moore & more than Moore" devices (multi-value logic, mem-computing, DNA sequencing, etc.) - energy conversion & storage devices (solar cells, LED, electro/photocatalysis, supercapacitor, etc.) - bio & electrochemical interfaces | <p style="text-align: center;">Nano-Materials/Devices Simulations</p> <p>The diagram illustrates a central hub of 'Novel 1st-principles simulation methods & software' surrounded by seven research areas, each with associated journal citations:</p> <ul style="list-style-type: none"> Electronics & Optoelectronics: Adv. Mater. 28, 5293 (2016); Adv. Mater. 29, 1603925 (2017); J. Am. Chem. Soc. 139, 8286 (2017) Spintronics: Carbon 84, 339 (2015); Nanotechnology 27, 47(2016) Photovoltaics & Photocatalysis: Adv. Energy Mater. 6, 1600583 (2016); Sci. Adv. 2, e1501459 (2016) Hybrid materials for Energy devices: Adv. Funct. Mater. 26, 5339 (2016); Adv. Funct. Mater. 28, 1870099 (2018) Theoretical spectroscopy Electro-mechanical systems: Carbon 67, 48 (2014); Nanoscale 8, 2343 (2016) Chem-bio sensing: Small 10, 774 (2014); Biosens. Bioelectron. 69, 186 (2015); ACS Appl. Mater. Sci. 10, 18227 (2018) Novel 1st-principles simulation methods & software: Complex environment, Photoexcitation, Energy & electron transport, pH. |
| <p>■ Recommended courses & Career after graduation</p> <ul style="list-style-type: none"> - Lab members are expected to have strong interest in (1) advanced quantum/device physics, (2) high-performance/AI computing, & (3) nex-generation device computer-aided design/development - In the past 2 years, 2 PhD graduates became permanent staff members in a National Lab (< 1 yr. after graduation); 1 postdoc was appointed as an associate professor in a leading Pakistanese university | <p>■ Introduction to other activities besides research</p> <ul style="list-style-type: none"> - Annual winter schools at ski resorts, Annual hiking trips to national parks, Weekly stroll+lunch - Regular attendances to International conferences |
| <p>■ Introduction to the Lab.</p> <ul style="list-style-type: none"> - According to <i>Nature</i> (http://nature.com/top100), among the top 100 most cited papers of all time in all fields, 12 of them are on density functional theory (DFT). - Our group is leading the development of novel 1st-principles, multiscale, & AI simulation theory and softwares that can deal with quantum transport & optical excitations in an efficient, consistent, and accurate manner. - This will have far-reaching implications for the understanding of the physics of non-equilibrium open quantum systems and the development of next-generation electronic/energy/bio-nanodevices. | |
| <p>■ Recent representative research achievements ('17~'19)</p> <ul style="list-style-type: none"> - "Semimetallicity and negative differential resistance from hybrid halide perovskite nanowires", Adv. Funct. Mater. (2019) - "HfO₂/HfS₂ hybrid heterostructure fabricated via controllable chemical conversion of two-dimensional HfS₂", Nanoscale (2018) - "Nitrogen doping of carbon nanoelectrodes for enhanced control of DNA translocation", ACS Appl. Mater. Interfaces (2018) - "Epitaxially self-assembled alkane layers for graphene electronics", Adv. Mater. (2017) <p>(10 papers on impact factor > 6 SCI journals in '17-'19; See http://nanocore.kaist.ac.kr for the full publication list)</p> <ul style="list-style-type: none"> - Prof. Y.-H. Kim, <i>Research Innovation Minister Award</i> (Nano Korea 2017, Ministry of Science, ICT, & Future Planning) - T. H. Kim, <i>Outstanding Presentation Award</i> (2019, KPS), & many other awards on group members | |

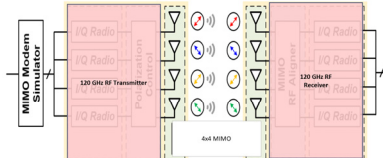
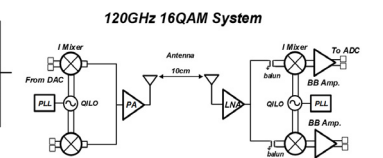
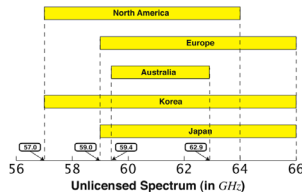
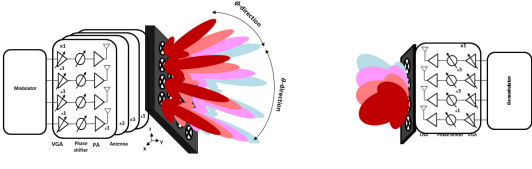
| | |
|--|--|
|  <p>Microwave Microsystems Laboratory</p> | <p>Contact information</p> <p>Professor : EE Building(E3-2) 6209 TEL : 042-350-3455 Lab. : EE Building(E3-2) 6210 TEL : 042-350-5455 Website : http://microlab.kaist.ac.kr</p> |
| <p>Current state of the Lab. (in 2019 Fall Semester)</p> <p>Postdoctoral Fellows : 1 PhD Students: 9 Master's Student: 3</p> | |
| <p>Research Areas</p> <p>Our group carries out advanced researches on millimeter-wave circuit and communication system based on CMOS technology.</p> <ul style="list-style-type: none"> - 200 Gbps Millimeter-Wave/THz Wireless Communication <div style="display: flex; justify-content: space-around;"> <div data-bbox="399 470 782 660">  <p><Conceptual Diagram for 4x4 MIMO Communication System></p> </div> <div data-bbox="813 470 1197 660">  <p><Block Diagram for 120GHz Communication></p> </div> </div> <ul style="list-style-type: none"> - For wireless chip-to-chip communication or short range device to device communication - 120 GHz center frequency, 16-QAM modulation scheme is used to achieve a 50 Gb/s data rate - 4X4 MIMO is implemented to achieve 200 Gb/s data rate - 60 GHz Millimeter-Wave Radio for Wireless Body Area Network <div style="display: flex; justify-content: space-around;"> <div data-bbox="367 817 670 1030">  <p><60-GHz Frequency Spectrum></p> </div> <div data-bbox="678 840 1212 1030">  <p><Conceptual Diagram of 60 GHz Beam-forming System></p> </div> </div> <ul style="list-style-type: none"> - For WBAN(Wireless Body Area Network), we targeted 10 Gb/s data rate with 3m distance - Beam-forming is adopted for NLoS(Non Line of Sight) Communication and Beam-tapering is adopted to reduce ISI by maximizing the SRR (Side-lobe Rejection Ratio) | |
| <p>Recommended courses & Career after graduation</p> <p>Recommended courses are Wireless Communications, Microelectronics, Electromagnetics, Radio engineering, Microwave engineering, and Antenna theory. After graduation, alumni are devoted as professors, researchers in government or private research center, and a CEO for venture company.</p> | <p>Introduction to other activities besides research</p> <p>To promote friendship among the members, Microlab holds workshop (summer, winter) twice a year, opens home coming day annually, and make events frequently for soccer, basketball, hiking, etc.</p> |
| <p>Introduction to the Lab.</p> <p>Microlab is the central laboratory chosen by National Research Foundation of Korea as the best NRL(2006) and ERC(2014). Our research based on CMOS circuit design in millimeter-wave/Terahertz band is targeted for very high speed next generation wireless communication and for pioneering new achievements for better human life. Through circuits and systems realization researches from CMOS circuits to system packaging, Microlab is the laboratory where members can develop their's originality and ability in modern research environments.</p> | |
| <p>Recent research achievements ('17~'19)</p> <ol style="list-style-type: none"> 1. Hee Sung Lee, Seung Hun Kim, Tae Hwan Jang, Hee Gyum Park, Byoung Chul Min, Seung Young Park, Chul Soon Park, 'Power-Efficient Spin-Torque Nano-Oscillator-Based Wireless Communication With CMOS High-Gain Low-Noise Transmitter and Receiver', IEEE Transaction on Magnetics, Vol.55, No.5, pp.1. May. 2019 2. Tea Hwan Jang, Hong Yi Kim, Dong Min Kang, Seung Hun Kim, Chul Soon Park, '60-GHz Low-profile, Wideband Dual Polarized U-Slot Coupled Patch Antenna with High Isolation', IEEE Transaction on Antennas and Propagation, Vol.67, No.7, pp.4453-4462. Jul. 2019 3. Joong Geun Lee, Tae Hwan Jang, Geon Ho Park, Hee Sung Lee, Chul Woo Byeon, Chul Soon Park, 'A 60-GHz Four-Element Beam-Tapering Phased-Array Transmitter With a Phase-Compensated VGA in 65-nm CMOS', IEEE Transaction on Microwave Theory and Technique, Vol.67, No.7, pp.2998-3009, Jul. 2019 4. Hyuk Su Son, Tae Hwan Jang, Seung Hun Kim, Kyung Pil Jung, Joon Hyung Kim, Chul Soon Park, 'Pole-Controlled Wideband 120 GHz CMOS Power Amplifier for Wireless Chip-to-Chip Communication in 40-nm CMOS Process', IEEE Transactions on Circuits and Systems II: Express Briefs, Vol.66, No.8, pp.1351-1355, Aug. 2019 <p>* A list of all publications before 2019 can be accessed from http://microlab.kaist.ac.kr.</p> | |

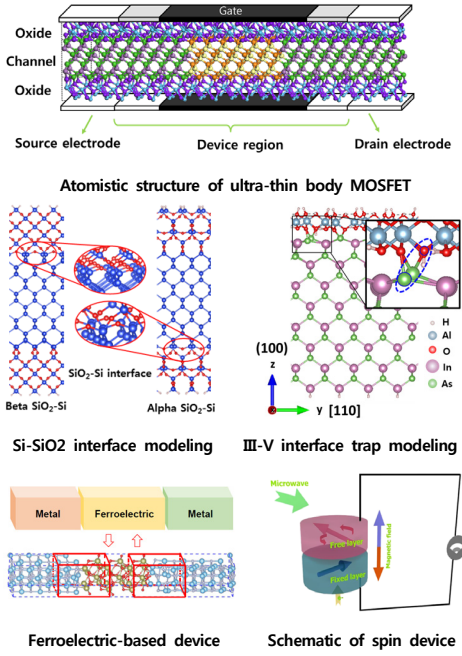
| | |
|--|--|
|  <p>Computational Nanoelectronics Laboratory http://cnl.kaist.ac.kr</p> | <p>■ Contact information</p> <p>Professor : E3-2, #6204 TEL : 042-350-7418 Lab. : E3-2, #5216 TEL : 042-350-7618 Website : http://cnl.kaist.ac.kr</p> |
| <p>■ Current state of the Lab. (in 2019 Fall Semester)</p> <p>Reserach Professor : 1 Postdoctoral Fellows : 2 PhD Students: 6 Master's Student: 2</p> | |
| <p>■ Research Areas</p> <p>As the feature size of conventional planar metal-oxide-semiconductor field-effect transistors (FETs) shrinks into the nanometer regime, performance of the devices is degraded due to short-channel effects caused by weakened gate control. To overcome this, novel devices such as nanowire, ultra-thin body FETs have emerged as the next generation devices. The classical or semi-classical approach is no longer valid for the nano-sized devices so quantum-mechanical, atom-level treatment is required.</p> <p>In our laboratory, we have been developing simulators for nano scaled devices based on the quantum mechanical principles. Si-based as well as non-Si devices such as Ge, III-V compounds, 2D materials, and ferroelectric are being considered. Tight-binding method and density functional theory (DFT) are used to treat the devices in the atomistic level and the non-equilibrium Green's function method are employed to solve the charge transport problem.</p> <p>We calculate physical parameters in a device level as wells as synchronization of Spin Torque Oscillator (STO) array by integrating with circuit theory. Also, we are currently suggesting novel designs of Spin-Transfer Torque driven Magnetic RAMs (STT-MRAMs) to overcome linewidth limitations that Si-based conventional memory devices encountered. For this, we analyze spin-based memory by using in-house micromagnetic and macromagnetic simulators.</p> |  |
| <p>■ Recommended courses & Career after graduation</p> <p>Prospective students should have good background knowledge on semiconductor physics and devices. Basic/advanced courses on the quantum mechanics, solid-state physics, and C language are also recommended to take. After graduation, they may continue their research career in universities or research institutes or work in semiconductor companies in Korea and overseas.</p> | <p>■ Introduction to other activities besides research</p> <p>It is strongly encouraged that students set aside time for regular physical exercises. Besides research, it is emphasized that students acquire ability to develop and express their idea, thinking, opinions through reading, writing and presentation (scientific or non-scientific).</p> |
| <p>■ Introduction to the Lab.</p> <p>Computational science/engineering is a new, a third way of doing research, besides the traditional way of doing research which is theory or experiment. Remarkable progress in the computer power and increasing needs for computation has led to the era of computational science/engineering. To meet the needs of the times, CNL provides its members with environments and experiences, which help them become the experts in semiconductor device physics and computational electronics. At the time of graduation, they are expected to be capable of handling all the semiconductor-device related issues that become more and more complex and ready to work both in industry and academia.</p> | |
| <p>■ Recent research achievements ('17~'19)</p> <p>[1] Y. Ahn and M. Shin, "Efficient Atomistic Simulation of Heterostructure Field-Effect Transistors," IEEE Journal of the Electron Devices Society, vol. 7, pp. 668-676, Jun. 2019. [2] S. Noh, D. H. Kang, and M. Shin, "Simulation of Strain Assisted Switching in Synthetic Antiferromagnetic Free Layer-Based Magnetic Tunnel Junction," IEEE Transactions on Magnetics, vol. 55, no. 4, pp. 3400705, Apr. 2019. [3] D. H. Kang, J. Lee, W. J. Woo, and M. Shin, "Spin torque nano-oscillators directly integrated on a MOSFET," IEEE Transactions on Nanotechnology, vol. 17, no. 1, pp. 122-127, Jan. 2018. [4] H. E. Jung, M. Shin, "Effects of Si/SiO2 interface stress on the performance of ultra-thin-body field effect transistors: A first-principles study," Nanotechnology, vol. 29, pp. 025201, dec. 2017. [5] M. Shin, "First-principles based quantum transport simulations of nanoscale field effect transistors," 2017 IEDM 초청강연.</p> | |

| | |
|---|--|
|  <p>High Speed Nano Electronics Laboratory</p> | <p>■ Contact information</p> <p>Professor : E3-2 1223-1 TEL : 042-350-3471 Lab. : E3-2 1227 TEL : 042-350-5471 Website : http://hsnl.kaist.ac.kr</p> |
| <p>■ Current state of the Lab. (in 2019 Fall Semester)</p> <p>PhD Students: 2 (Joint-Research) & Active Co-Research with External Research Institutes/Univ/Co.</p> | |
| <p>■ Research Areas</p> <p>Sub-THz(Tera Hertz) RF-CMOS Device Modeling & Circuit Design</p> <p>▶ Device Modeling of 110 GHz Nano-CMOS FETs and Design of 110 GHz RF-ICs</p> <p>In modern technology, there are many high frequency applications such as communication and radar system. For cost and size reduction, silicon based devices are often used for integrated circuits. However, as frequency goes higher, it is very hard to predict the performance because of increasing parasitics. Therefore, we have been studying novel de-embedding methodologies for RF-CMOS characterization up to 110 GHz. It is expected that improved de-embedding techniques could lead to <i>precise modeling and thus, precise circuit design</i>. The opportunities to encounter advanced-silicon technologies will be given.</p> <p>THz(Tera Hertz) Nano-Quantum Devices & ICs Design</p> <p>▶ Development of THz(Tera-Hertz) Devices & ICs for Upcoming THz-electronics applications</p> <p>As a mature candidate for beyond-CMOS era, a quantum-effect nano device such as Resonant Tunneling Diodes (RTDs) has been consistently developed in our laboratory. The physics-based structure modeling of RTD for THz-level oscillation frequency is proceeded using a quantum device simulator. The THz-level RTD analog/RF/digital ICs have been designed and fabricated in compound semiconductor clean-room facilities. For free-space radiation, THz on-chip antennas have been also integrated. The development of THz RTD ICs with on-chip antenna array can be <i>an innovative compact/powerful high power and efficient THz technology</i> for new opening-up system demands in THz electronics system applications.</p> | |
| <p>■ Recommended courses</p> <p>Physical Electronics, Electronic Circuits, High Freq. Electronic Devices, Microwave Engineering, etc.</p> <p>■ Career after graduation</p> <p>Samsung Electronics/SK Hynix/ADD/ETRI/KIST/Academia</p> | <p>■ Introduction to other activities besides research</p> <p>▶ Laboratory workshop & picnic ▶ Casual group meetings with sandwich or coffee</p> |
| <p>■ Introduction to the Lab.</p> <p>High Speed Nanoelectronics Lab (HSNL) conducts research in next-generation devices and ICs with focus on high speed and high frequency system applications. The lab is currently involved in research on Sub-THz/THz-Freq. Range (6G & Beyond 5G) high-frequency nano device modeling/characterization/fabrication and innovative TMICs (Terahertz Monolithic Integrated Circuits) & 3D Integrated Micro-Systems.</p> <p><i>HSNL is one of world-leading univ. labs in the field, currently recruiting any interested and ambitious students in the related fields of world-top level intense competition and developments.</i></p> | |
| <p>■ Recent research achievements ('18~'19)</p> <p>[1] M. Kim and K. Yang, "A Sub-THz RTD-pair Oscillator with Enhanced RF Output Power Characteristics", IEEE IPRM/ISCS, CSW-2019, Nara, Japan, May 2019.</p> <p>[2] M. Kim and K. Yang, "The Output Power Characteristics of the Series-connected RTD Pair", IEEE IPRM/ISCS, CSW-2019, Nara, Japan, May 2019.</p> <p>[3] J. Park, J. Lee, K. Lee, and K. Yang, "A 24-GHz Low-Power RTD-Based ON-OFF Keying Oscillator With an RTD Pair Configuration", IEEE Microwave and Wireless Components Letters, Vol. 28, No. 6, pp. 521-523, June 2018.</p> | |

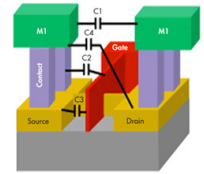

Nano-CMOS FinFET Modeling

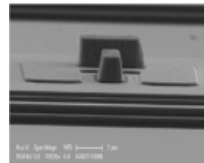

Resonant Tunneling Diode (RTD)

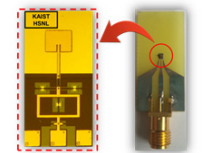

Terahertz RTD Oscillator

| | |
|---|---|
|  | <p>■ Contact information</p> <p>Professor: #6202 E3-2 TEL : 042-350-3483 Lab.: #6207, 6219 E3-2 TEL : 042-350-5483 Website : ioel-kaist.org</p> |
| <p>■ Current state of the Lab. (in 2019 Fall Semester)</p> <p>Postdoctoral Fellows : 2 PhD Students: 12 Master's Student: 7</p> | |
| <p>■ Research Areas</p> <div style="display: flex; justify-content: space-between;"> <div style="width: 48%;"> <p>Organic Light-Emitting Diodes (OLEDs) for Displays & Lighting Applications</p>  <p>Organic and Perovskite Solar Cells for Photovoltaic Energy Generation</p>  <p>Organic TFTs for low-cost /flexible ICs</p> <ul style="list-style-type: none"> Highly flexible TFTs and memories based on polymer gate dielectrics Integrated flexible sensors • Transparent TFTs • Ink-free jet printing  </div> <div style="width: 48%;"> <p>Organic Light-Emitting Diodes (OLED) and their applications: As future display panels and solid-state lighting, OLEDs are promising due to their advantages such as high color purity, applicability on versatile designs including flexible and transparent devices, and low power consumption. Our lab focuses on realizing flexible and efficient devices with various form-factors based on electrical and optical engineering. We have published several research papers in high-impact factor journals in recognition of these results, such as flexible and efficient devices based on dielectric-metal-dielectric and graphene electrodes, low-cost plastic OLEDs, transparent OLEDs, high-contrast-ratio OLEDs, etc.</p> <p>Photovoltaics and their applications: Organic solar cells and perovskite solar cells have attracted considerable attention as a renewable and alternative energy source. IOEL is contributing to solar cell commercialization such as building-integrated photovoltaics and vehicle-integrated photovoltaics by developing flexible and semi-transparent characteristics of solar cells.</p> <p>Devices for future electronics: State-of-the-art applications for future electronics including wearable / patched devices require not only various functions but also diverse form factors. Researches on thin film transistors and sensor devices are conducted with non-Si based semiconductors, such as organic semiconductors, 2D materials, and transparent metal-oxide semiconductors. Fields of interest are encouraged to be expanded, are currently focused on transparent thin film transistors, flexible organic memories, vertical transistors for high current drivability, organic sensors, solution-processed self-aligning nano-patterning techniques and organic vapor-jet printing techniques.</p> </div> </div> | |
| <p>■ Recommended courses & Career after graduation</p> <p>Recommended courses are Introduction to Physical Electronics (EE211) and Semiconductor Devices (EE362), Organic Electronics (EE568), and Display Engineering (EE563). After graduation, research institutes (national or company) and academic careers are possible.</p> | <p>■ Introduction to other activities besides research</p> <p>IOEL promotes public relations by producing original researches through publishing journal papers and attending various domestic/foreign academic conferences or seminars. Also, we have lab workshops and sports days every semester.</p> |
| <p>■ Introduction to the Lab.</p> <p>Integrated Organic Electronics Lab (IOEL) focuses on developing novel device architectures and processes based on organic and other emerging semiconductors in the following areas: display & lighting, energy, and flexible low-cost electronics. Recent research trends no longer centralize on device performance enhancement, but focus more on the realization of various functionalities. To meet these requirements through devices with higher levels of integration and complicated systems, knowledge on electrical devices is highly necessary. For students with knowledge of electronics and great interest in interdisciplinary fields, we hope you will join IOEL and seize the chance to apply your electrical engineering skills to various areas.</p> | |
| <p>■ Recent research achievements</p> <p>[1] J. Song, <i>et al.</i>, "Lensfree OLEDs with over 50% external quantum efficiency via external scattering and horizontally oriented emitters", <i>Nature Communications</i> 9, 3207 (2018) [2] H. Lee, <i>et al.</i>, "Toward all-day wearable health monitoring: An ultralow-power, reflective organic pulse oximetry sensing patch", <i>Science Advances</i> 4(11) (2018) [3] S. Lee, <i>et al.</i>, "Organic flash memory on various flexible substrates for foldable and disposable electronics", <i>Nature Communications</i> 8, 725 (2017) [4] H. Kim <i>et al.</i>, "Empowering Semi-Transparent Solar Cells with Thermal-Mirror Functionality", <i>Advanced Energy Materials</i> 6(14), (2016) (Front Cover, broadcast in YTN)</p> | |

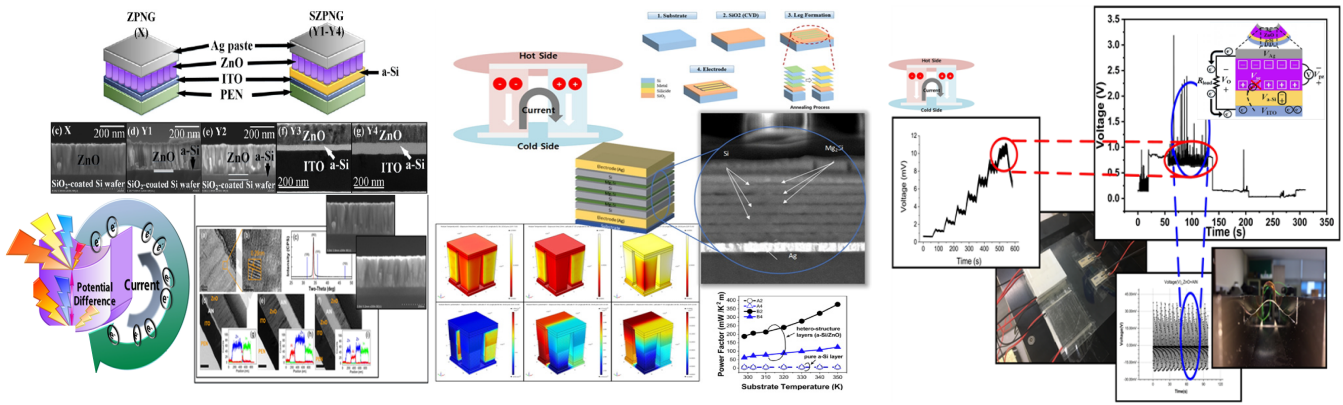
| | | |
|--|---|--------------------------|
| <div style="text-align: center;">  </div> | <p>■ Contact information</p> <p>Professor : Giwan Yoon TEL : 042-350-7411 Lab. : E3-3, Device innovation facility TEL : 042-350-7511 Website : http://tnslab.kaist.ac.kr</p> | |
| <p>■ Current state of the Lab. (in 2019 Fall Semester)</p> <p>Postdoctoral Fellows : 0 PhD Students: 5 Master's Student: 1</p> | | |
| <p>■ Research Areas</p> <ul style="list-style-type: none"> - 1) Research on piezoelectric energy harvesting technology based on nano structures & devices for Wearable/IoT applications - 2) Research on thermoelectric energy harvesting technology based on nano structures & devices for Wearable/IoT applications - 3) Research on piezo-thermo hybrid energy harvesting technology for Wearable/IoT applications and sensor networks | | |
| Piezoelectric energy harvesting | Thermoelectric energy harvesting | Hybrid energy harvesting |
|  | | |
| <p>★ Current research goal: The realization of highly-efficient self-powered sensor networks through the convergence of nanostructured thermoelectric energy harvesting devices and innovative sensor networks for Wearable/IoT applications.</p> | | |
| <p>■ Recommended courses & Career after graduation.</p> <ul style="list-style-type: none"> - Introduction to physical electronics, Semiconductor devices, Semiconductor integrated circuits etc. are recommended. - Graduated students are working in universities, global electronics companies, national research institutes, etc. | <p>■ Introduction to extra curricular activities.</p> <ul style="list-style-type: none"> - Frequently, a student gathering of refreshment is held at a nice place (e.g. italian restaurant) where meaningful discussions are interactively made on any issues or concerns related to lab research work as well as current technology development trends, etc. | |
| <p>■ Introduction to the Lab.</p> <p>We are working on the research of high-efficiency 1) piezoelectric, 2) thermoelectric energy harvesting devices in nano-scale. Recently, we are working on piezo-thermo hybrid energy harvesting devices actively based on their design and fabrication in nanostructures.</p> | | |
| <p>■ Recent research achievements ('18~'19)</p> <ol style="list-style-type: none"> [1] Jaekwon Ha et al., "An experimental study of a-Si/ZnO-stacked hetero-structures for potential thermoelectric energy harvesting applications ", Applied Physics Letters, 2018. [2] Jihwa Lee et al., " Characteristics of hetero-structured thermoelectric devices with a-Si/Mg₂Si-stacked thin film layers ", Electronics Letters, 2018. [3] Buil Jeon et al., " Effect of a-Si thin film on the performance of a-Si/ZnO-stacked piezoelectric energy harvesters ", Applied Physics Letters, 2018. [4] Munhyuk Yim et al., " Fabrication of Tandem-type Vertically Integrated Nanogenerators by In-situ Deposition of AlN/ZnO Films ", Journal of Semiconductor Technology and Science, 2019. [5] Yeongseon Kim et al., " Electrical characteristics and detailed interfacial structures of Ag/Ni metallization on polycrystalline thermoelectric SnSe ", Journal of materials science & technology, 2019. [6] Yeongseon Kim et al., " Practical evaluation of electrical contact resistance of thermoelectric legs at high operation temperature ", Journal of Materials Science: Materials in Electronics, 2019. [7] Chongsei Yoon et al., " A Feasibility Study of Fabrication of Piezoelectric Energy Harvesters on Commercially Available Aluminum Foil ", Energies, 2019. | | |



3D Micro-Nano Structures Laboratory

■ **Contact information**

Professor: Nanofab Center 513 (E19)

TEL : 042-350-3476

Lab.: Nanofab Center 523 (E19)

TEL : 042-350-5476

Website: <http://MEMS.kr/>

■ **Current state of the Lab. (in 2019 Fall Semester)**

Postdoctoral Fellows : 0 PhD Students: 6 Postmaster fellows : 1 Master's Student: 6

■ **Research Areas**

- ▷ We focus on the **high-performance 3-dimensional micro/nano-electro-mechanical systems (M/NEMS)**.
- ▷ We research on **unique device-design, fabrication, and demonstration** technologies.
- ▷ Based on our superior abilities in overall device-technology, we have developed the **world-best electrical devices, such as nano/micro-mechanical switches (DC/RF), optical components, and nano-sensor devices**.
- ▷ We have also **widen the research-field** into bio-sensor, health-care monitoring, energy harvesting devices and so on, **with lab members having various undergraduate majors**.

■ **Nano/micro-switch for DC & RF applications-----**

Through the micro/nano-mechanical switches, ideal switching characteristics such as no-leakage current and infinite sub-threshold swing can be achieved (**Fig. 1**), but the high operational voltage and low reliability still should be improved. We have been improving characteristics of the mechanical switch and trying to apply it into memory, logic & RF applications.

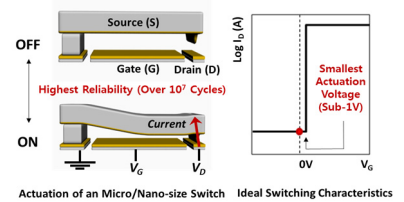

Fig. 1 Ideal mechanical-switch

■ **N/MEMS for Optical Components-----**

Based on our research experience on micro/nano fabrication, we make novel complex micro/nano-structures decorated optical films (**Fig. 2**). These films are for giving special abilities to display such as thinner feature, transparency, glasses-free 3D and local dimming. We also developed micro-shutter for smart-window, AR and transparent OLED-display. Recently, we built a start-up company named MEMSLUX, and aim to see our technology being widely used in the near future.

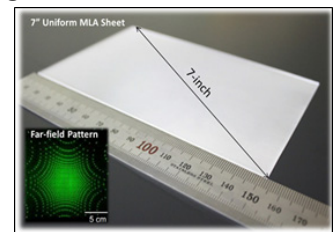

Fig. 2 Optical film for display

■ **Nano-sensor devices for future electronics-----**

To realize the industry 4.0, it is essential to fabricate high performance sensor devices in high-yield, reliable, and reproducible manners. Based on our large-area high-resolution and reproducible nano-fabrication technologies, we reliably explore unprecedented physical/chemical phenomena and apply them to develop high-performance optical, physical, tactile, bio, and optical sensor devices (**Fig. 3**).

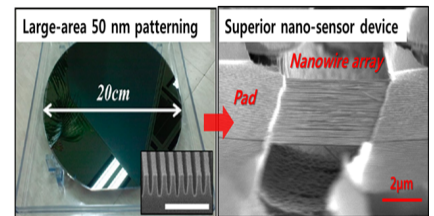

Fig. 3 Nano-structured sensor

■ **Recommended courses & Career after graduation**

Among EE courses, semiconductor devices, integrated circuit devices, and MEMS in EE perspective are recommended. Additionally, it is also recommended to have a basic understanding of physics and chemistry.

So far, 20 PhD. and 42 MS degrees have been conferred. Graduates have entered global leading industries such as Samsung, LG, SK Hynix, Broadcom, and also continue their research career as postdoctoral researchers in Northwestern, Massachusetts Institute of Technology(MIT), John's Hopkins, and National Institutes of Health(NIH).

■ **Introduction to other activities besides research**



Annual Workshop :

- Present research results and plan
- Enjoy winter sports(ski and board)

Homecoming Day :

- Share information with laboratory students and graduates

Leisure Activity :

- Enjoy sports regularly (Soccer, Bowling, Basketball)

■ **Recent research achievements**

- In total, 106 international journals, 108 international conference, 44 international and 94 domestic patents
- **Journals : Nature Nanotechnology, Advanced Materials, ACS Nano, Nano Letters etc.**
- **Awarded for our researches from IEEE, Samsung Electronics, Society of Micro and Nano Systems, and KAIST. (KAIST Top 10 Research Achievements of 2018)**

| | |
|--|--|
|  <p>Advanced Devices for Energy Conversion Lab</p> | <p>■ Contact information Professor : E3-2 6208 TEL : +82-42-350-1722 Lab. : KI Building (E4) A523 TEL : +82-42-350-1762 Website : http://adec.kaist.ac.kr</p> |
| <p>■ Current state of the Lab. (in 2019 Fall Semester) Postdoctoral Fellows : 1 PhD Students: 7 Master's Student: 5</p> | |
| <p>■ Research Areas</p> <p>1. Thin-film controlling process We controlled the film coating process such as spontaneous spreading (SS) process, water floating process, thermal rolling process, and etc. These researches propose new techniques for low cost, large-area coating for organic devices.</p> <p>2. Novel transparent and stretchable conductors An outstanding performance of a transparent and stretchable conductive electrode is essential for efficient opto-electronic devices including OPV, OLED, and wearable sensor. We investigate the novel transparent conductors such as silver nanowires, metal nanostructures, hybrid electrodes and graphene to replace ITO.</p> <p>3. Various type of photovoltaics We investigate the various photovoltaic devices using organic, quantum dot, perovskite, and their hybrid materials. We optimize fabrication condition and making high efficiency photovoltaics.</p> <p>4. Highly efficient photovoltaics We focus on increasing various photovoltaics power conversion efficiency by using thin-film controlling techniques and optimizing molecular weight, treatment method, and additive control. Also, we are trying to make highly efficient devices by studying and simulating ray-optics.</p> | |
| <p>■ Recommended courses & Career after graduation</p> <p><u>Recommended courses</u> :</p> <p>Introduction to Organic Electronics (EE568), Solid State Physics (EE661), Advanced Electromagnetic Theory I (PH507)</p> <p><u>Career after graduation</u> : Professor, Researchers of national research center, Company (SAMSUNG)</p> | <p>■ Introduction to other activities besides research</p> <p><u>Exercise activity</u> : Futsal, Basket ball, Badminton</p> <p><u>Group teamwork</u> : Once a month, we are having a teamwork time.</p>  |
| <p>■ Introduction to the Lab.</p> <p>ADEC lab has been studied on the organic/inorganic photovoltaics, novel transparent electrode, and film coating process since 2010. We have monthly meetings with the professor and all group members and weekly team meetings to discuss and brainstorm for our research. Also, we have free meeting with seniors and junior to help research life.</p> | |
| <p>■ Recent research achievements ('17~'19)</p> <p>[1] SW. Baek et al., "A hydro/oxo-phobic top hole-selective layer for efficient and stable colloidal quantum dot solar cells", Energy & Environmental Science 11, 2078-2084 (2018)</p> <p>Journal articles (Total : 20 SCI articles) : 2019 : 2, 2018 : 8, 2017 : 10</p> | |

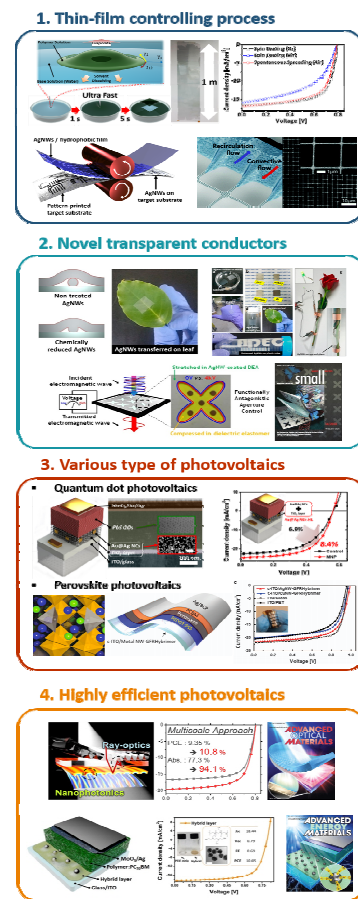

| | |
|---|---|
|  | <p>■ Contact information</p> <p>Professor : E3-2 Rm 4220 TEL : 042-350-7436 Lab. : E3-2 Rm 4233 TEL : 042-350-7536 Website : http://bmm.kaist.ac.kr/</p> |
| <p>■ Current state of the Lab. (in 2019 Fall Semester)</p> <p>Postdoctoral Fellows : 0 PhD Students: 5 Master's Student: 6</p> | |
| <p>■ Research Areas</p> <p>- Our group aims to develop novel systems for biomedical applications 1) Developing biocompatible and flexible material 2) Applying micromachining and MEMs technology to these materials 3) Integrating these devices with interface circuits.</p> <p>[Non invasive ultrasonic brain stimulation]</p> <p>- Recently, the next generation convergence of modern engineering and medical industry has attracted much attention. Our group is conducting animal experiments using non-invasive methods using our own ultra-light transducers, with a particular focus on brain stimulation research. We are working on the responses to these stimuli.</p> <p>[Portable chemical sensor]</p> <p>- In order to be able to recognize environmental problems that can affect human health, we are researching chemical sensor devices that are easy to carry and can sense the surroundings in real time. These devices are manufactured through a process called microelectromechanical systems, commonly called MEMs.</p> <p>[Adhesive epidermal sensor]</p> <p>- While many researches have recently been conducted on devices attached to the human body, there is still insufficient research on how to attach them to the human body. In order to solve this problem, our research is focused on sensors that are very strong and can carry electricity. It is harmless to human body and manufactures electronic devices that can be applied with various sensors.</p> | |
| <p>■ Recommended courses & Career after graduation</p> <p>- Recommended course: MEMs electronics, nano/bio electronics</p> <p>- Career after graduation: Samsung Semiconductor, TmaxSoft, Samsung Foundry, Post Doc., Stanford</p> | <p>■ Introduction to other activities besides research</p> <p>We annually attend the KMEMS (Korea Micro Electro Mechanical Systems) conference held at Jeju Island and eat out time to time.</p> |
| <p>■ Introduction to the Lab.</p> <p>- In our lab, we can start with a simulation of the device and go through the process, from the planning of our own research to the actual device. In addition, in the laboratory, students from various departments can not only build up knowledge in a wide range of fields, but also create a research environment in which excellent papers can be produced through various applications and applications.</p> | |
| <p>■ Recent research achievements ('17~'19)</p> <p>International Journals: 16, International conference papers: 9</p> <p>[1] "Multifunctional multi-shank neural probe for investigating and modulating long-range neural circuits in vivo", Nature communication, 2019.</p> | |

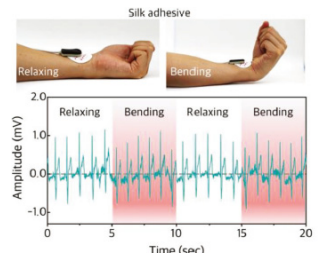
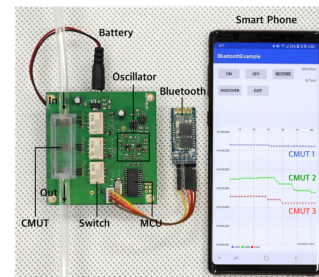

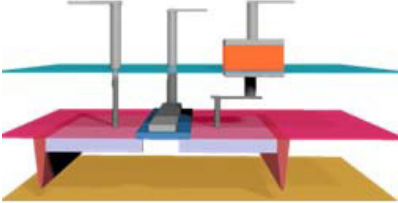
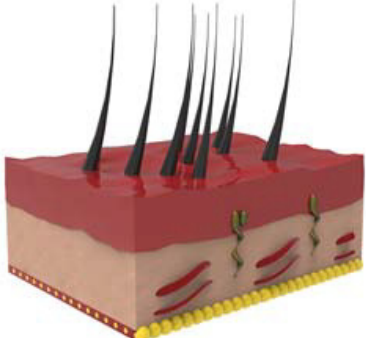
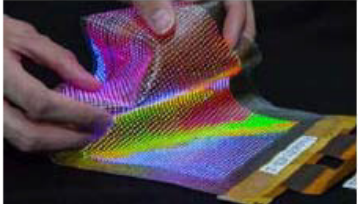
| | |
|---|---|
|  | <p>■ Contact information</p> <p>Professor : E19 S217 TEL : 042-350-7444 Lab. : E19 S217 TEL : 042-350-7444 Website : http://antonis.kaist.ac.kr</p> |
| <p>■ Current state of the Lab. (in 2019 Fall Semester)</p> <p>Postdoctoral Fellows : 2 PhD Students: 4 Master's Student: 5</p> | |
| <p>■ Research Areas</p> <p>Electronic Skin: The electronic skin ultimately provides human-like skin to the robot, and the tactile sensor. It provides a user interface based on empathy and emotion for communication between the device and human being. The electronic skin, which consists of a network of electronic devices sensing tactile senses, is used in high performance wearable electronic devices that attach to the skin through the modification of nanomaterials and existing semiconductor technologies.</p> <p>Hafnia Ferroelectric device New component hafnia ferroelectric materials have superiority in process and performance over existing MTJs or other resistive devices. In this case, it can be used extensively in storage class memory as well as non-volatile logic, multi-valued logic, neuron architecture</p> <p>Stretchable Display "Third Generation Flexible Display" must satisfy the following conditions ① With higher than that of a large-area plastic AMOLED of 60 inches or more, ② A complete Flexible Form Factor capable of folding at least 30% of area standard, > 10,000 times repeatability and a curvature radius of less than 1mm.</p> <p>Amorphous metal Unlike crystalline metals, amorphous metals do not have a regular structure, which makes them excellent in mechanical properties such as strength and ductibility</p> |    |
| <p>■ Recommended courses Physical Electronics, Thin Film Transistor, Semiconductor IC Technology, Semiconductor Devices, etc.</p> <p>■ Career after graduation Samsung Electronics/SK Hynix/ETRI/KIST/Academia</p> | <p>■ Introduction to other activities besides research</p> <ul style="list-style-type: none"> ▶ Regular sports activities (Futsal, badminton, table tennis, catch ball etc.) ▶ Laboratory workshop & picnic in summer ▶ Monthly lunch meeting with sandwich or coffee |
| <p>■ Introduction to the Lab.</p> <p>ANTONIS Lab is currently performing research on core materials, process, device and integration technology of wearable IoT sensor, electronic skin, hafnia ferroelectric device, storage class memory and stretchable display. We have published quite a number of publications in these fields.</p> | |
| <p>■ Recent research achievements ('17~'19)</p> <p>[1]"Transparent Semiconducting Oxide Technology for Touch Free Interactive Flexible Displays," Proceeding of IEEE (2015)</p> <p>[2]"The Influence of Hydrogen on Defects of In-Ga-Zn-O Semiconductor Thin-Film Transistors With Atomic-Layer Deposition of Al₂O₃", IEEE Elec. Dev. Lett. (2016)</p> <p>[3]"Low-voltage, High-sensitivity and High-reliability Tactile Sensor Array with Fully Inkjet-printed Stretchable Conducting Electrode," Nano Energy (2017)</p> <p>[4]"Vertically stacked nanocellulose tactile sensor," Nanoscale (2017)</p> <p>[5]"Excellent Resistive Switching Performance of Cu-Se-Based Atomic Switch Using Lanthanide Metal Nanolayer at the Cu-Se/Al₂O₃ Interface," ACS Applied Materials and Interfaces (2018)</p> | |

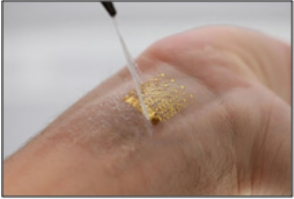
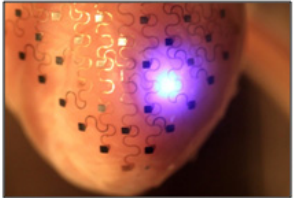
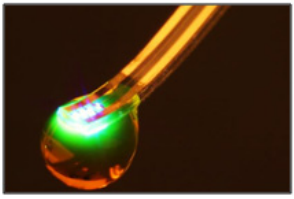
| | |
|---|---|
| <h2 style="color: red;">Bio-Integrated Electronics and Systems Laboratory</h2> | <p>■ Contact information Professor : Nanofab center (E19), Room 516 Lab. : Nanofab center (E19), Room 522 Website : http://jeongresearch.org</p> |
| <p>■ Current state of the Lab. (in 2019 Fall Semester) Postdoctoral Fellows : 0 PhD Students: 3 Master's Student: 3</p> | |
| <p>■ Research Areas</p> <p>Our mission is to invent the future generation "soft" bioelectronics and biomedical systems for advancing healthcare and biomedical research. Research areas in our group include design and fabrication of flexible/stretchable electronics, photonic microsystems, and microfluidic devices for various applications such as health/wellness monitoring, disease diagnosis and therapy, human-machine interfaces, and neuroscience.</p> <p style="color: red;">"Wearable" Skin-like Electronics</p> <p>Conventional biomedical devices mounted on our body are rigid, bulky, and its mechanical properties do not match with the property of the human tissue. Based on flexible/stretchable electronics technologies, our group develops soft, flexible, and stretchable devices with diagnostic and therapeutic capabilities, which can be conformally wrapped on curvilinear-shaped skin. We are broadly interested in stretchy bio-integrated electronics that integrate multiple modalities (e.g. electronics, photonics, and microfluidics)</p> <p style="color: red;">"Implantable" Soft Electronics</p> <p>Implantable devices have been drawing significant attentions in biomedical research for continuous monitoring of force, pressure, temperature, and electrophysiological signals inside living subjects. Implantable electronic systems must be small in size, compatible with biological tissue, and sturdy enough to withstand the physical forces within the body. Our research focus is to develop soft, stretchable sensors and actuators that enable high spatiotemporal resolution recording and control; and that conform to the micro-geometry of 3-D tissue without creating damaging local stresses. Our particular interests are in implantable cardiac devices and wireless multifunctional neural probes for the brain.</p> <div style="display: flex; justify-content: space-around; align-items: center;"> <div style="text-align: center;"> <p>Epidermal</p>  </div> <div style="text-align: center;"> <p>Cardiac</p>  </div> <div style="text-align: center;"> <p>Neural</p>  </div> </div> | |
| <p>■ Recommended courses & Career after graduation</p> <p>Recommended courses: MEMS, micro/nanofabrication, circuit design, embedded systems, etc.</p> <p>Potential career path:</p> <p>Industry: Electronics, Semiconductor, Medical, etc. Academia: Univ. Professors, Researchers at National Labs</p> | <p>■ Introduction to other activities besides research</p> <p>We hold annual group party and workshop. In addition, we attend various international conferences including Transducers, MEMS, EMBC, MRS, BMES, etc.</p> |
| <p>■ Introduction to the Lab.</p> <p>Our group works on multidisciplinary research, crossing the areas of EE, ME, BME, materials, and physics. We are actively collaborating with Washington Univ. School of Medicine, Georgia Tech, Yonsei University Medical School, etc.</p> | |
| <p>■ Recent research achievements ('17~'19)</p> <p>- 2015-2016: <i>Cell</i> (2015); <i>Science Advances</i> (2016).</p> <p>[1] "Wireless optofluidic brain probes for chronic neuropharmacology and photostimulation," <i>Nature Biomedical Engineering</i> 3, 655-669 (2019).</p> <p>[2] "Miniaturized, battery-free optofluidic systems with potential for wireless pharmacology and optogenetics," <i>Small</i> 14, 1702479 (2018).</p> <p>[3] "Preparation and implementation of optofluidic neural probes for in vivo wireless pharmacology and optogenetics," <i>Nature Protocols</i> 12(2), 219-237 (2017).</p> | |

| | |
|--|---|
|  <p>Nano Electronics & Energy Device Lab.</p> | <p>■ Contact information</p> <p>Professor : Nano Fab Center # 515 TEL : 042-350-3485 Lab. : Nano Fab Center # 521 TEL : 042-350-5485 Website : http://need.kaist.ac.kr</p> |
| <p>■ Current state of the Lab. (in 2019 Fall Semester)</p> <p>PhD Students: 10 Master's Student: 8</p> | |
| <p>■ Research Areas</p> <p>Next Generation Semiconductor</p> <p>- Ultra-Flexible silicon devices</p> <p>Our group has been developing ultra-thin single crystalline silicon (Si) nano-membrane device to realize high performance flexible logic circuits by utilizing the high flexibility due to the ultra-thinness and the high performance due to the single crystallinity of the channel material.</p> <p>Wearable Thermoelectric Generator</p> <p>Thermoelectric generators (TEG) are devices which convert temperature differences (heat) into electrical energy. Since the thermal energy is everywhere in our daily life, it can be one of the most promising energy solutions in the future. Our group has been focused on a flexible TEG, which can be used for wearable electronic systems.</p> <p>Advanced CMOS Technology</p> <p>- 3D semiconductor devices</p> <p>Today is the era of 3D semiconductor devices. Our group has been developing new processing technology, such as atomic layer deposition of metal, for the application of 3D devices, doing collaboration with SK Hynix Semiconductor Ind.</p> <p>- Ge Transistor</p> <p>Germanium has higher hole (x4) and electron (x2) mobility than silicon, being one of the candidate materials to replace silicon in the future. Our group has been doing research on 3D germanium transistor technology targeting 7-nm technology node and beyond..</p>  | |
| <p>■ Recommended courses & Career after graduation</p> <p>Recommended courses : Introduction to Physical Electronics (EE211), Semiconductor Devices (EE362), Semiconductor IC Technology (EE463).</p> <p>Usual careers after graduation includes national/foreign research institutes, post-doctoral researchers, semiconductor companies, professor, etc.</p> | <p>■ Introduction to other activities besides research</p> <p>Our group has regular outdoor activities, such as football, basketball, and so on. Half-yearly workshop at resorts has been helpful to building up good teamwork.</p> |
| <p>■ Introduction to the Lab.</p> <p>As Prof. Cho had been working for IMEC (Belgium), Hyundai Electronics (currently SK hynix), and National university of singapore, students have chances to do collaboration works with many other groups and companies in the world. Our lab has several research projects from National Research Foundations, domestic companies, as well as overseas companies. We have world-class laboratories and facilities for the semiconductor research.</p> | |
| <p>■ Recent research achievements ('17~'19)</p> <p>KAIST top 10 new technologies in 2011&2015/ KAIST research award in 2015/ Best national R&D achievement in 2015 awarded by Korea government/ Grand Prix from Netexplo Award 2015/ Grand prize in 2019 KAIST Research Day/paper publications in top journals and conferences including Nature Materials, IEDM, VLSI symposium, etc.</p> | |

| | |
|---|---|
|  <p>Advanced Display and Nano Convergence laboratory</p> | <p>■ Contact information Professor : Device Innovation Facility(E3-3) 2308 TEL : 042-350-3482 Lab. : Device Innovation Facility(E3-3) 2302 TEL : 042-350-5482 Website : http://adnc.kaist.ac.kr</p> |
| <p>■ Current state of the Lab. (in 2019 Fall Semester) Postdoctoral Fellows : 1 PhD Students: 15 Master's Student: 7</p> | |
| <p>■ Research Areas : The ADNC laboratory conducts applied and convergent research based on advanced display and nanotechnology.</p> <ul style="list-style-type: none"> ▶ Transparent and flexible display – fundamental research on OLED-based next-generation display technologies, including encapsulation, electrodes, and an out-coupling enhancement method applicable to transparent and flexible displays. ▶ Wearable and stretchable display – wearable display: research on textile based clothing-like wearable displays. Displays can be formed on fabric, or displays formed on fiber can be woven to fabric. These technologies will provide a foundation for various applications such as display curtains or carpets in future, and will also affect the fashion industry. Stretchable display: beyond curved and bended displays, conducting basic study of stretchable displays akin to skin that can be stretched. ▶ Bio and Medical applications (band type photo-therapy and electronic patch) - beyond the function of information displays, research on photo-therapy, health-care, and electronic patches by using flexible and stretchable devices. ▶ Nanotechnology and nano-convergence – conducting research on new innovative technologies for 1) a color filter electrode combining the functions of an electrode and a color filter, 2) an oxide TFT with enhanced performance, improved stability, and transparent flexible structures, 3) quantum dot display as a new display mode using inorganic materials in nano size to control light, which has recently attracted attention in the display field. <div data-bbox="1157 392 1476 1041" style="float: right; text-align: right;">  <p>Textile Skin Acne treatment [14], Skin rejuvenation [17], Photo-protection [18] Wound healing [16], Anti-inflammatory [19]</p> </div> | |
| <p>■ Recommended courses & Career after graduation The course titled 'Display engineering' is recommended. A total of 39 people (as Ph.D. 21, M.S. 16, Post-doc 2) graduated from ADNC Lab. are working in university, corporations, and national institutes as professors and research engineers.</p> | <p>■ Introduction to other activities besides research We emphasize teambuilding through various sports activities selected by our members such as futsal, basketball and etc. Summer vacation every year Gathering with alumni every spring Light hiking every fall</p> |
| <p>■ Introduction to the Lab. The ADNC lab. conducts research covering a broad area of advanced displays, and has published 166 SCI papers, delivered 234 presentations in conferences, and filed 134 patents. This lab. led the Center for Advanced Flexible Display Convergence (CAFDC), an 'Advanced Research Center Program' of the National Research Foundation of Korea (NRF) from 2007 to 2016. From 2017, the lab. is in charge of the important part in "Attachable Photo Therapeutics Center for e-Healthcare", a new Engineering Research Center (ERC) of NRF, which is funded until 2024. Professor Kyung Cheol Choi has been in charge of the LG Display-KAIST cooperation center from 2010 until now, and our laboratory hence has many opportunities for technology seminars and industry-academia cooperation with LG Display. From previous research on the world's most efficient PDP to current research on textile-based washable optoelectronic modules, we have reported numerous excellent results and have attracted attention from various media around the world. Students interested in future displays should take note of our lab.</p> | |
| <p>■ Recent research achievements ('17~'19) 28 SCI papers, 33 presentations in conference, 20 patents applied for or registered. Among them, a wearable photobiomodulation patch and textile-based washable optoelectronic modules were published in Advanced Materials Technologies in 2018 and Energy and Environmental Science in 2019 as cover paper, respectively.</p> <div data-bbox="1181 1769 1460 1948" style="float: right; text-align: right;">  </div> | |

|  | <p>■ Contact information Professor : KI Building (E4) C413 Lab. : Device Innovation Faculty (E3-3) 2302 KI Building (E4) C418 Website : http://mndl.kaist.ac.kr</p> | <p>TEL : 042-350-7427 042-350-7627 042-350-7527</p> | | | | | | | | | | | | | | | | | | | | | |
|--|---|---|-------------------------|--------------------------------|---|-----------------------------------|---|------------------------------------|--|---|---------------------------------|--|------------------------------|--|--|---|--|--|---|-----------------------------------|--|--|--|
| <p>■ Current state of the Lab. (in 2019 Fall Semester) Research Professor: 1 Postdoctoral Fellows: 1 PhD Students: 9 Master's Student: 4</p> | | | | | | | | | | | | | | | | | | | | | | | |
| <p>■ Research Areas</p> <p>▶ Synthesis of Graphene and 2D Materials</p> <ul style="list-style-type: none"> - Research on 2D materials for innovative devices - Synthesis of high quality and uniform 2D materials with properties close to theoretical values - Our lab possesses various skills for synthesis of metallic graphene, semiconducting TMDs (transition metal dichalcogenides) such as MoS₂ and MoSe₂, and insulating hexagonal boron nitride (h-BN) - A variety synthetic approaches for fabrication of 2D materials based devices - Besides conventional CVD processes, novel synthetic approaches such as MOCVD (metal organic chemical vapor deposition), photothermal synthesis, and ALD (atomic layer deposition) have been studied to overcome the existing process limitations <p>▶ 2D Materials Applications</p> <ul style="list-style-type: none"> - Research on applications based on materials growth, processes, and device fabrications of 2D materials - Graphene based electrodes for transparent electrodes and doping techniques for luminance efficiency improvement using atomically thin and high electron mobility of graphene - Utilization of 2D semiconducting materials for TFT array channels in backplane for displays - Development of low-power integrated circuits based on 2D materials - Anticipated that our researches can be applied to key techniques for soft electronics, one of the next generation electronic devices, using flexible substrate platforms <p>▶ Neuromorphic and Memristor Devices</p> <ul style="list-style-type: none"> - Study of memristor devices and arrays for new memory and logic gates - Next generation computing enabling logic-in-memory, totally different from von Neumann architecture in which memory and logic are separated - Research on memristor-based synaptic devices for neuromorphic computing - With the suggested memristors, device-to-system simulation performed for artificial neural network - Analogue computing and MAC* operation using memristor crossbar arrays <p style="text-align: right;">*MAC: multiply and accumulation</p>    | | | | | | | | | | | | | | | | | | | | | | | |
| <p>■ Recommended courses & Career after graduation We encourage you to take following courses.</p> <ul style="list-style-type: none"> ■ Introduction to Physical Electronics (EE211) ■ Semiconductor Devices (EE362) ■ Semiconductor IC Technology (EE463) <p>MNDL alumni are studying abroad, working for a research institute or semiconductor companies such as Samsung Electronics and SK Hynix.</p> | <p>■ Introduction of other activities besides research We take a coffee break after lunch in a daily routine, and play team sports such as futsal and basketball once in a week. Besides, a lot of chances are provided to attend domestic and international conferences. As annual events, we have a strawberry party in April and year-end party in December.</p> | | | | | | | | | | | | | | | | | | | | | | |
| <p>■ Introduction of the Lab. Molecular and Nano Device Laboratory (MNDL) is focusing on the molecular-scale materials and devices for the next-generation IT-ET-BT convergence technology, spanning the electronics and photonics applications. Our vision of research is “creative researches to change the world”. All research members can choose creative research topics based on the abovementioned topics considering students' opinions. Freedom of time management is guaranteed for self-regulating and creative researches. Especially, MNDL is mainly supervising GRC (Graphene/2D Materials Research Center) and CAMD³ (Center for Advanced Materials Discovery towards 3D Display). Individual member can have opportunities to perform in-depth study by cooperating with other members to achieve outstanding performance.</p> | |  <p>KAIST GRC 그래핀/2D소재 연구센터 GRC (Since 2012)</p>  <p>KAIST CAMD³ 디스플레이 미래소재 연구센터 CAMD³ (Since 2016)</p> | | | | | | | | | | | | | | | | | | | | | |
| <p>■ Recent research achievements ('17~'19)</p> <table border="0" style="width: 100%;"> <thead> <tr> <th style="text-align: center;">Graphene & 2D Materials</th> <th style="text-align: center;">Flexible Electronics & Display</th> <th style="text-align: center;">Neuromorphic Devices & Integrated Circuit</th> </tr> </thead> <tbody> <tr> <td>1. 2D Materials, 6, 025025 (2019)</td> <td>1. Adv. Electron. Mater., 5, 1800688 (2019)</td> <td>1. Adv. Mater., 31, 1806663 (2019)</td> </tr> <tr> <td>2. Adv. Fuct. Mater., 29, 1807550 (2019)</td> <td>2. ACS Appl. Mater. & Inter., 11, 7626 (2019)</td> <td>2. Nano Letters, 19, 839 (2019)</td> </tr> <tr> <td>3. Nanoscale, 10, 15205 (2018) [Inside Back Cover]</td> <td>3. Sci. Rep., 9, 1199 (2019)</td> <td>3. Adv. Func. Mater., 28, 1804844 (2018)</td> </tr> <tr> <td>4. Adv. Func. Mater., 27, 1703545 (2017) [Front Cover]</td> <td>4. ACS Appl. Mater. & Inter., 10, 40212</td> <td>4. Adv. Func. Mater., 28, 1704725 (2018) [Front Cover]</td> </tr> <tr> <td>5. J. Mater. Chem A, 5, 14950 (2017) [Front Cover]</td> <td>5. Adv. Electron. Mater., 1800251, (2018)</td> <td>5. Nano Research, 10, 2459 (2017)</td> </tr> <tr> <td></td> <td>6. Adv. Func. Mater., 28, 1704435 (2018)</td> <td></td> </tr> </tbody> </table> | | | Graphene & 2D Materials | Flexible Electronics & Display | Neuromorphic Devices & Integrated Circuit | 1. 2D Materials, 6, 025025 (2019) | 1. Adv. Electron. Mater., 5, 1800688 (2019) | 1. Adv. Mater., 31, 1806663 (2019) | 2. Adv. Fuct. Mater., 29, 1807550 (2019) | 2. ACS Appl. Mater. & Inter., 11, 7626 (2019) | 2. Nano Letters, 19, 839 (2019) | 3. Nanoscale, 10, 15205 (2018) [Inside Back Cover] | 3. Sci. Rep., 9, 1199 (2019) | 3. Adv. Func. Mater., 28, 1804844 (2018) | 4. Adv. Func. Mater., 27, 1703545 (2017) [Front Cover] | 4. ACS Appl. Mater. & Inter., 10, 40212 | 4. Adv. Func. Mater., 28, 1704725 (2018) [Front Cover] | 5. J. Mater. Chem A, 5, 14950 (2017) [Front Cover] | 5. Adv. Electron. Mater., 1800251, (2018) | 5. Nano Research, 10, 2459 (2017) | | 6. Adv. Func. Mater., 28, 1704435 (2018) | |
| Graphene & 2D Materials | Flexible Electronics & Display | Neuromorphic Devices & Integrated Circuit | | | | | | | | | | | | | | | | | | | | | |
| 1. 2D Materials, 6, 025025 (2019) | 1. Adv. Electron. Mater., 5, 1800688 (2019) | 1. Adv. Mater., 31, 1806663 (2019) | | | | | | | | | | | | | | | | | | | | | |
| 2. Adv. Fuct. Mater., 29, 1807550 (2019) | 2. ACS Appl. Mater. & Inter., 11, 7626 (2019) | 2. Nano Letters, 19, 839 (2019) | | | | | | | | | | | | | | | | | | | | | |
| 3. Nanoscale, 10, 15205 (2018) [Inside Back Cover] | 3. Sci. Rep., 9, 1199 (2019) | 3. Adv. Func. Mater., 28, 1804844 (2018) | | | | | | | | | | | | | | | | | | | | | |
| 4. Adv. Func. Mater., 27, 1703545 (2017) [Front Cover] | 4. ACS Appl. Mater. & Inter., 10, 40212 | 4. Adv. Func. Mater., 28, 1704725 (2018) [Front Cover] | | | | | | | | | | | | | | | | | | | | | |
| 5. J. Mater. Chem A, 5, 14950 (2017) [Front Cover] | 5. Adv. Electron. Mater., 1800251, (2018) | 5. Nano Research, 10, 2459 (2017) | | | | | | | | | | | | | | | | | | | | | |
| | 6. Adv. Func. Mater., 28, 1704435 (2018) | | | | | | | | | | | | | | | | | | | | | | |

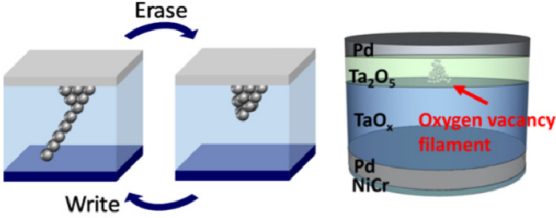
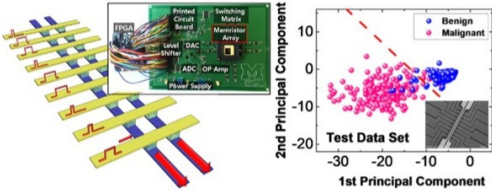
| | |
|--|--|
|  | <p>■ Contact information</p> <p>Professor : E3-2 #5224 TEL : 042-350-7450 Lab. : E3-2 #5235 TEL : 042-350-7550, 7650 Website : www.shinhyunlab.kaist.ac.kr</p> |
| <p>■ Current state of the Lab. (in 2019 Fall Semester)</p> <p>Postdoctoral Fellows : 0 PhD Students: 0 Master's Student: 3</p> | |
| <p>■ Research Areas</p> <p>Memristor Devices Development</p> <div style="display: flex; align-items: center;">  <div style="margin-left: 20px;"> <p>Memristors, also called RRAMs or resistive switching devices, have attracted tremendous attention as possible candidates for many applications such as neuromorphic computing hardware, next-generation memory cells, logic applications and security applications. The inherent memory effect in the simple two-terminal devices allows efficient data storage and parallel write/read-out system. Other properties such as high density, low power consumption, long cycling endurance and sub-nanosecond switching speed have been also demonstrated in memristor devices. However, conventional memristors suffer from unavoidable spatial-temporal variation due to uncontrollable, stochastic filament formation. Our lab is now developing a new strategy to achieve uniform switching through CMOS compatible materials/fabrication steps.</p> </div> </div> <p>Artificial Neural Network using Memristor Devices</p> <div style="display: flex; align-items: center;">  <div style="margin-left: 20px;"> <p>In recent years, deep learning and artificial neural networks has achieved unprecedented accuracies in large-scale recognition and classification tasks by utilizing supercomputing resources. While several application-specific integrated circuit (ASIC) solutions utilizing CMOS have been previously proposed, limitations still exist on communication bottlenecks, energy consumptions and online learning capabilities. To address all issues in AI hardware, the community is moving towards utilizing memristor as artificial synapses because they can offer fast parallel neuromorphic computing at extremely small device footprint with low power consumption. The goal of this project is to develop large-scale neural network arrays for artificial intelligence (AI) hardware based on new design of artificial synapses (memristors).</p> </div> </div> <p>Integrated Systems Development</p> <p>Another major focus of the ENIS lab would be the heterogeneous integration of intelligent systems from sensors to computing units. By utilizing memristor-based computing systems, the team will demonstrate on-body decoding system from neural probing and security applications using biometrics.</p> | |
| <p>■ Recommended courses & Career after graduation</p> <p>Major pre-requisites are Semiconductor device physics, Fabrication, Neural networks. However, other students who have CS and circuit background are also welcome. The students can be in academia and industry as a core member world-wide.</p> | <p>■ Introduction to other activities besides research</p> <p>The lab holds annual group parties and joint-workshops for perspective collaboration. We also attend international conferences including MRS, IEDM, etc. We also plan to have regular outdoor activities, such as soccer, basketball, hiking and so on.</p> |
| <p>■ Introduction to the Lab.</p> <p>The group works on multi-disciplinary research areas including material sciences, device physics, circuits and neural network algorithms. Therefore, our group is able to give students a chance to participate in various fields besides device area. We will have lots of collaboration from Universities and Industries.</p> | |
| <p>■ Recent research achievements ('17~'19)</p> <p>[1] "SiGe Epitaxial Memory for Neuromorphic Computing with Reproducible High Performance Based on Engineered Dislocations," Nature Materials, 17, 335-340 (2018) (Highlighted in News & Views of Nature Materials, Spotlighted in MIT main page, MIT news)</p> <p>[2] "Remote epitaxy through graphene for two-dimensional material based layer transfer," Nature, 544, 340-343 (2017)</p> <p>[3] "Experimental Demonstration of Feature Extraction and Dimensionality Reduction using Memristor Networks," Nano Letters, 17, 3113-3118 (2017) (Highlighted in Nature Nanotechnology)</p> | |

| | |
|---|--|
|  | <p>■ Contact information Professor : Nanofab (E19) #514 TEL : 042-350-3477 Lab. : Nanofab (E19) #524 TEL : 042-350-5477 Website: http://nobelab.kaist.ac.kr</p> |
| <p>■ Current state of the Lab. (in 2019 Fall Semester) Postdoctoral Fellows : 1 PhD Students: 9 Master's Student: 7</p> | |
| <p>■ Research Areas</p> | |
| <p>● AI based Machine Learning for CMOS Device Design</p>  <ul style="list-style-type: none"> Machine learning (ML) and deep learning (DL) technology for CMOS device and design like AlphaGo ML & DL based failure analysis and classification ML & DL for neuromorphic system | <p>● Neuromorphic Device (Hardware-based AI)</p>  <ul style="list-style-type: none"> Bio-inspired neuromorphic system Synapse device Neuron device Neuron-synapse co-integration Mimicry of human brain by hardware based neuron-synapse On-chip and off-chip learning Brain-machine interface |
| <p>● Novel CMOS and memory (More than Moore)</p>  <ul style="list-style-type: none"> 3-D MOSFET (FinFET and gate-all-around MOSFET) Novel structure and new material based CMOS Gate-less & capacitor-less DRAM 3-D V-NAND Flash memory RRAM, fabric-based memristor beyond von-Neumann architecture Security device and self-curable CMOS | <p>● Energy Harvester</p>  <ul style="list-style-type: none"> Triboelectric nanogenerator (TENG) Hybrid energy harvester Self-powered sensor system for IoT Self-powered security device Self-powered CMOS with energy harvester Extra-terrestrial CMOS application by TENG (Chip-based Star-ship project with NASA) |
| <p>■ Recommended courses & Career after graduation</p> <ul style="list-style-type: none"> Semiconductor device and physics Perspective students who majored in physics, chemistry and material science are welcomed Career after graduation: academia (professor), post-doctoral researcher (Universities abroad, NASA, etc.), researcher in national institutes, and an engineer in major industries (Samsung Electronics, SK hynix, etc.) | <p>■ Introduction to other activities besides research</p>  <p>Weekly sports (Soccer)</p>  <p>Weekly Sports (Basketball)</p> |
| <p>■ Introduction to the Lab</p> <ul style="list-style-type: none"> Very active research productivity (~ 30 papers/year) in highly reputed journal and society Various research topics (Free subject that a student wants to study) Many best paper awards with cash prize (scholarship) |  <p>Outdoor Activities</p>  <p>Beer Party</p> |
| <p>■ Recent research achievements ('17~'19)</p> <p>※ 319 papers in SCI journal (52 papers with an impact factor of 10 or higher, 10 cover papers), 129 papers in international conference [Total ~ 450 papers/15 years] [1] A Recoverable Synapse Device Using a Three-Dimensional Silicon Transistor (Advanced Functional Materials, 2018) [2] First Demonstration of a Logic-process Compatible Junctionless Ferroelectric FinFET Synapse for Neuromorphic Applications (IEEE Electron Device Letters, 2018) [3] Multidirection and Multi-amplitude Triboelectric Nanogenerator (Advanced Energy Materials, 2018). [4] Functional circuitry on commercial fabric (Nano Letters, 2017).</p> | |

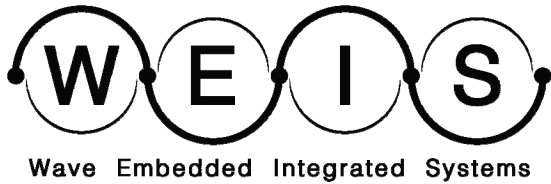

Contact information

Professor : Nanofab center s-216 TEL : 042-350-3449
 Laboratory : Nanofab center s- 216 TEL : 042-350-9940 ~ 9945
 Website : <https://weis.kaist.ac.kr>

Current state of the Lab. (in 2019 Fall Semester)

Postdoctoral Fellows : 0 PhD Students: 16 Master's Student: 6

Research Areas

CMOS Power Amplifier for 5G Wireless communication Beam-forming system

In a wireless communication system, a power amplifier (PA) is a key block that amplifies the signal power at the end of the transmitter. Unlike other components, PAs have been implemented with a compound such as GaN and GaAS, rather than with a CMOS process, because it is very hard to satisfy the stringent linearity requirement at the high power region with CMOS. However, CMOS PAs are getting the limelight in the upcoming 5G system, which uses phased-array-system for beamforming. It requires less linear power for each PA but more numbers of it. Therefore, CMOS integration of PAs will save a lot of cost. We have researched CMOS PAs that are comparable with compound PAs, and now actively adapting it to 5G wireless communication system.

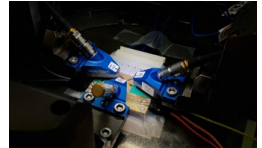
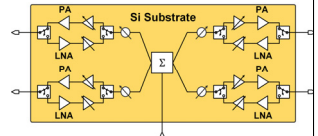

UWB Radar sensor On a Chip in CMOS process

Development of Radar system technology based on CMOS process facilitates subminiature, low-cost system by using System on Chip(SoC) technologies. Also, pulse mode operational UWB radar sensor system has advantage on resolution, accuracy and power consumption. Based on this, we develop radar systems in various frequencies and its applications. So far, we developed and transferred 24GHz human-sensing radar technology for automatic door and street lamp. Currently, we are developing 79GHz short-range automobile radar for automatic driving or manless car, and 60GHz hand-motion sensing radar for Human computer interaction(HCI). These technologies can be applied to various fields such as robots, drones, bio-signal measurements, etc.

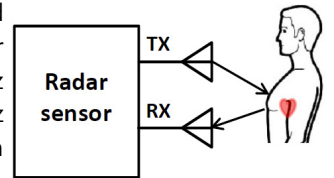
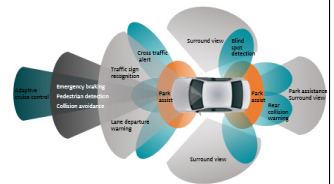

Sub-terahertz Circuit system

THz band has been attracted because MHz and GHz band is saturated and high-data rate is needed. In THz band RF circuit system can be integrated on a chip including antenna, and can be used for high data rate chip-to-chip communication. We are researching more compact THz circuit system using CMOS Technology.

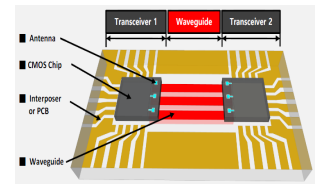

Recommended courses & Career after graduation

Electronic circuit and RF engineering courses are recommended for undergraduate students. Digital circuit and digital signal processing are also helpful courses for our research field. Most of WEIS graduate find work at Samsung, Hynix, Qualcomm or national laboratory such as ETRI or ADD. There are many alumni employed as a professor after taking post-doctor course abroad.

Introduction to other activities besides research

We do sports activities(soccer, table tennis, badminton, bowling) once a week. We regularly have cultural activities(watching movie, sports game, shows) together. Also, we go trip or climb mountain 2~3 times annually.

Introduction to the Lab.

WEIS LAB is specialized in a high frequency circuit designing. we aim at making the world wireless. Not giving up on what many believed to be impossible, we have produced meaningful outcomes that are recognized by both academia and industry. We are always wide open to anyone who is creative and passionate







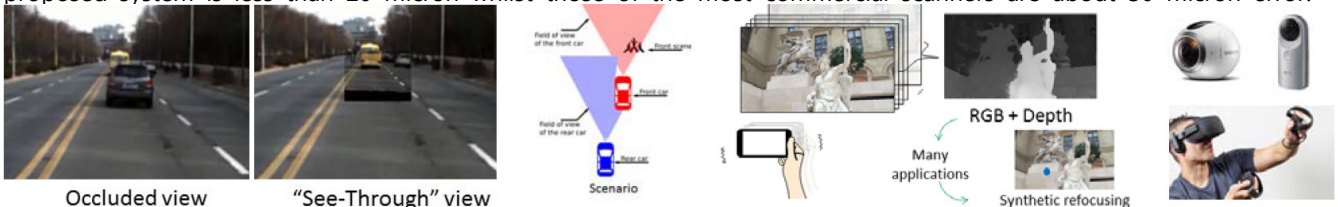

Recent research achievements ('17~'19)

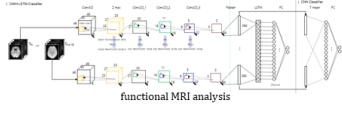
[1] J. Park, S. Lee, D. Lee and S. Hong, "A 28GHz 20.3% Transmitter Efficiency 1.5° Phase-Error Beamforming Front-End IC with Embedded Switches and Dual-Vector Variable-Gain Phase Shifters," in 2019 ISSCC, vol. 9, no. 8.
 [2] S. Kang, G. Jeong and S. Hong, "Study on Dynamic Body Bias Controls of RF CMOS Cascode Power Amplifier," in IEEE Microwave and Wireless Components Letters, vol. 28, no. 8, pp. 705-707, Aug. 2018.
 [3] W. Lee and S. Hong, "Low-loss and small-size 28 GHz CMOS SPDT switches using switched inductor," in Proc. IEEE Radio Freq. Integr. Circuits Symp. (RFIC), June 2018, pp. 148-151.

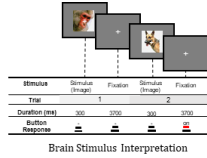

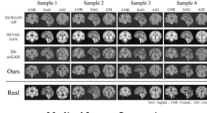
Signal Division

| | |
|--|--|
|  <p>Robotics and Computer Vision Laboratory</p> | <p>Contact information Professor : N1 Room #209 TEL : 042-350-3465 Lab. : N1 Room #211 TEL : 042-350-5465 Website : http://rcv.kaist.ac.kr</p> |
| <p>Current state of the Lab. (in 2019 Fall Semester) Postdoctoral Fellows : 3 PhD Students: 17 Master's Student: 14</p> | |
| <p>Research Areas Deep Learning / Computer Vision Deep convolutional neural network is recently shows huge impact in vision society. Our AttentionNet achieves Top-5 CLS-LOC error of 14.73% in ILSVRC 2015 which is significantly outperforming the previous winner in ILSVRC 2014 (26.70% by Google) by a gain of +12. Furthermore, there have been many deep learning research done including prediction of 3D information from single image, action recognition from video, automatic recycling system via qarbage recognition, and recifying image resolution using thermo-sensors or ligh-field cameras.</p>  <p>Intelligent Robots / Vehicle Applications Using various 2D/3D sensors, research on the recognition and tracking of multiple moving objects is currently being undertaken. Also, the real-time mapping and navigation technologies of new environments and the sensing on humanoid robots are being researched. We participated in the competition as members of team KAIST for developing vision system of DRC-HUBO+. Moreover, our laboratory founded the P3 digital electric car center, and developed various future systems for recognizing the surrounding environment for intelligent vehicle applications. The project with BOSCH Germany on See-through cars deal with seeing through the front car or occlusions via networking between cars.</p> <p>3D Reconstruction Various researches about reconstructing 3D shape of real-world objects are proposed. By using multi-view stereo initial mesh and photometric stereo method, high-quality mesh model can be obtained. A multi-view structured-light system is developed for highly accurate 3D modeling. The mean reconstruction error by the proposed system is less than 20 micron whilst those of the most commercial scanners are about 30 micron error.</p>  | |
| <p>Recommended courses & Career after graduation We have produced 44 doctorates and 90 masters since 1993. Our alumni's careers are diverse, spanning both domestic and international positions. An outstanding case would be the startup of Puloon Technologies, as well the numerous alumni in executive positions within national research centers, Samsung, LG, and etc. In addition, many of our alumni are working as researchers in notable international institutes (like MS, Adobe, Intel and Apple) or as professors in universities.</p> | <p>Introduction to other activities besides research Various events are held within the lab. For the cultivation of global leaders, opportunities are provided for internships in major international research institutes (MSR, MSRA, Adobe, NASA-Ames, CMU etc), attendance in major conferences abroad, and yearly academic exchange events with foreign universities (Peking University, University of Tokyo, etc). Through these events, we are able to strengthen our solidarity as well as obtaining a global perspective.</p> |
| <p>Introduction to the Lab. As a nationally appointed research group, our research contributions reside in improving recognition systems and vision sensors, establishment of the P3Digicar Center (NCRC), and collaborative research with various industrial partners, like Samsung electronics, Hyundai motor company and Bosch.</p> | |
| <p>Recent research achievements ('17~'19)</p> <ul style="list-style-type: none"> - International Journals: 5 TPAMI (IF:8.33), 2 IJCV (IF:8.22), 1 TOG (6.495), 4 TIP (IF:5.071), 1 IJCV (IF:11.541), 2 Sensors (IF:3.031), 1 PRL (IF:9.227), 1 RAS, 1 MVA (IF:1.788) publications. - International Conferences: 12 CVPR, 6 ICCV, 1 ECCV, 1 NIPS, 3 ICRA, 5 IROS, 1 ICLR, 2 BMVC, 1 RSS, 2 ACM MM, 1 EMNLP, 4 AAAI, 4 WACV papers published. - Samsung Human Tech Award: 2 Gold ('18, '17), 1 Silver ('17), 2 Honorable Mentions ('19, '18) | |

| | |
|--|---|
|  <p>BREIL Brain Reverse Engineering and Imaging Lab</p> | <p>■ Contact information</p> <p>Professor : ITC building 511 TEL : 042-350-3490 Lab. : ITC building 521 TEL : 042-350-8172~4 Website : http://brain.kaist.ac.kr</p> |
| <p>■ Current state of the Lab. (in 2019 Fall Semester)</p> <p>PhD Students: 5 Master's Student: 9 Researcher: 1 Staff: 2</p> | |
| <p>■ Research Areas</p> <div style="display: flex; justify-content: space-around; align-items: flex-start;"> <div style="text-align: center;">  <p>functional MRI analysis</p> </div> <div style="text-align: center;">  <p>Super Resolution</p> </div> <div style="text-align: center;">  <p>Brain Stimulus Interpretation</p> </div> </div> <div style="display: flex; justify-content: space-around; align-items: flex-start; margin-top: 10px;"> <div style="text-align: center;">  <p>Semantic Embedding</p> </div> <div style="text-align: center;">  <p>Medical Image Generation</p> </div> <div style="text-align: center;">  <p>Anomaly detection</p> </div> <div style="text-align: center;">  <p>Image Enhancement</p> </div> </div> <div style="text-align: center; margin-top: 20px;">  <p>Brain Reverse Engineering and Deep Learning</p> </div> <div style="display: flex; justify-content: space-between; margin-top: 10px;"> <div style="width: 45%;"> <p>Linguistic Intelligence</p> <ul style="list-style-type: none"> - Natural Language Processing - Visual Question and Answer </div> <div style="width: 45%;"> <p>Visual Intelligence</p> <ul style="list-style-type: none"> - Object Tracking - Super Resolution - Medical Imaging - Image Generation </div> </div> <div style="display: flex; justify-content: space-between; margin-top: 10px;"> <div style="width: 45%;"> <p>Brain Decoding</p> <ul style="list-style-type: none"> - functional MRI analysis - Brain Stimulus Interpretation </div> <div style="width: 45%;"> <p>Neuromorphic Algorithm</p> <ul style="list-style-type: none"> - Spiking Neural Network </div> </div> | |
| <p>■ Recommended courses & Career after graduation</p> <p>We recommend laboratory candidates to take Introduction to Brain IT and coursework in machine learning, information theory, and signal processing.</p> <p>We have Ph. D graduates (postdoc at Samsung medical center, CTO at Omnious, etc.) and graduates with master's degree (Samsung DMC Lab, Lunit, LG, ETRI, Hynix, Hyundai Motors, UCL Wellcome Trust Centre for Neuroimaging, Ph. D candidates, CEO of Omnious and bHaptics, etc.).</p> | <p>■ Introduction to other activities besides research</p> <p>Professor Dae-Shik Kim is currently serving as the director of KOLON-KAIST Life Style Innovation Center and professor in charge of non-degree courses in the 4th Industrial Revolution Frontier Leadership Program.</p> <p>In our Laboratory, we freely share and socialize cultural life such as MT, dining, sports and birthday parties.</p> |
| <p>■ Introduction to the Lab.</p> <p>Our laboratory conducts studies that lead the current flow of science and technology. We are actively engaged in cutting-edge research in areas such as deep learning, neuromorphic engineering and brain decoding, enriched by active collaboration with leading groups. Striving for excellence and innovation, we have entered the DARPA Robotics Challenge with the HUBO laboratory KAIST and dispatched our members for overseas research at Cambridge U.K, UCL, Leiden (Netherlands), EPFL (Switzerland), and Stanford. Alongside collaborating with top authorities in the industry and academia, we also nurture a venture spirit that has led to the establishment of successful venture startups such as Omnious and bHaptics.</p> | |
| <p>■ Recent research achievements (2019)</p> <p>[1] Tetiana Parshakova, Francois Rameau, Andriy Serdega, In So Kweon and Dae-Shik Kim. "Latent Question Interpretation Through Parameter Adaptation", IEEE/ACM Transactions on Audio, Speech, and Language Processing (2019), ISSN: 2329-9290, DOI 10.1109/TASLP.2019.2929647</p> <p>[2] Deokyun Kim, Minseon Kim, Gihyun Kwon and Dae-Shik Kim, "Progressive Face Super-Resolution via Attention to Face Landmark", the 30th British Machine Vision Conference(BMVC) 2019, Cardiff, United Kingdom, Sep 9-12, 2019</p> <p>[3] Gihyun Kwon, Chihye Han and Dae-Shik Kim, "Generation of 3D Brain MRI Using Auto-Encoding Generative Adversarial Networks", the 22nd International Conference on Medical Image Computing and Computer Assisted Intervention(MICCAI) 2019, Shenzhen, China, Oct 13-17, 2019</p> | |



VIDEO AND IMAGE COMPUTING LAB

Video and Image Computing Laboratory

Contact information

Prof. : Rm# 1107, Bldg. N24 TEL : 042-350-7419
 Lab. : Rm# 1106, 1108, Bldg. N24 TEL : 042-350-7519
 Website : http://viclab.kaist.ac.kr

Current state of the Lab. (2019 Fall Semester)

Postdoctoral Fellows : 0 PhD Students: 12 Master's Student: 8

Research Areas

The research areas of VIC Lab include Perception and Machine/Deep Learning based Images/Video Processing/Understanding, Object Detection/Tracking and Recognition, Deep Image/Video Restoration and Quality Enhancement, and Deep Image/Video Compression.

Deep Learning based Image/Video Restoration and Quality Enhancement

Based on deep convolutional neural networks and recurrent neural networks, we are focusing on (i) image/video super-resolution, (ii) video frame interpolation for high frame rates, (iii) SDR/HDR video (inverse) tone mapping, (iv) motion deblur, (v) compression artifact reduction, and (vi) denoising and demosaicking for camera's Bayer array images. Our research pursues studying high-performance algorithms for leading-edge levels as well as low-complexity algorithms for practical applications

Automatic Target Detection and Recognition for Synthetic Aperture Radar Imagery

Synthetic Aperture Radars (SAR) are widely used for surveillance systems because they can operate under all weather conditions, day and night due to a powerful penetrating property. We are studying deep learning based automatic target detection and recognition (ATD/R) algorithms for SAR imagery where deep convolution neural networks explored to detect small-sized target candidates and classify them into appropriate categories. Since SAR data is difficult and expensive to acquire, we develop generative networks that can generate realistic SAR data from images acquired by other image sensors.

Deep Image and Video Compression

Data compression is essential in many multimedia applications. We are studying deep networks that can learn redundant information via network training so as to extract essential information for compact representation of image and video.

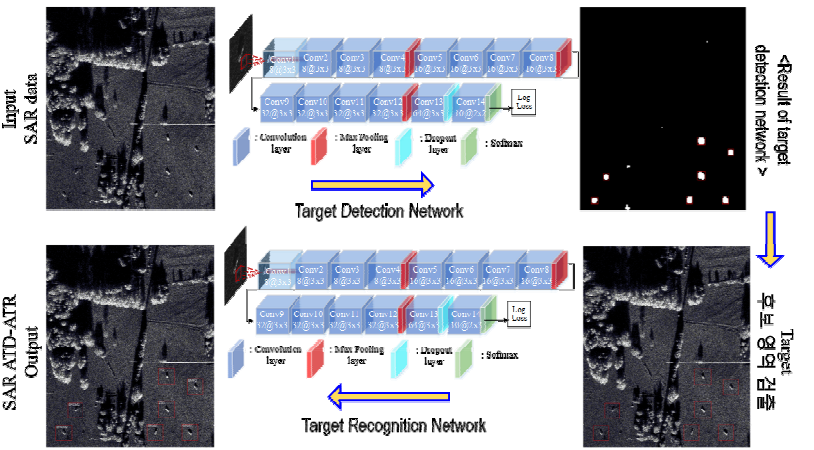
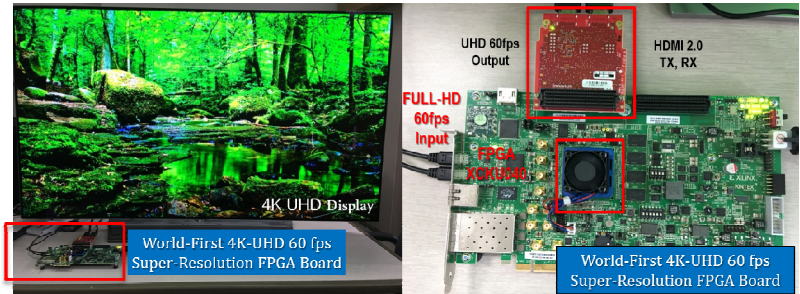
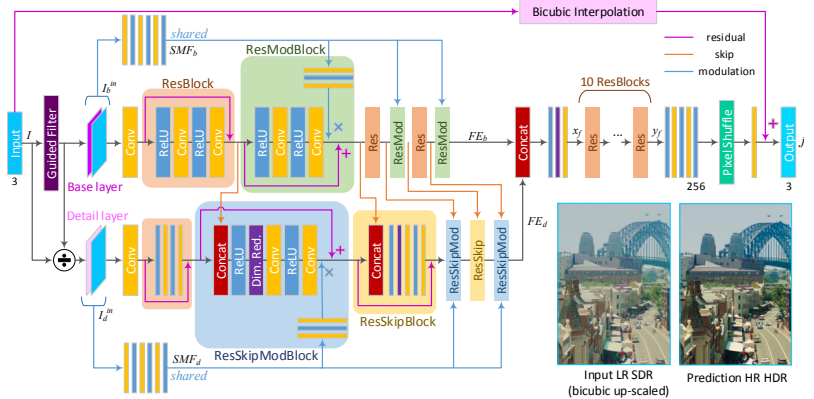

Recommended courses & Career after graduation

Recommended classes are digital image processing, machine learning and deep learning. After graduation, students often work with global companies, start-up companies, academia and research institutes.

Introduction to other activities besides research

VIC labers enjoys various outside-lab activities such as skying, movie watching, mountain climbing and sports.

Introduction to the Lab.

VIC Lab aims to send out leaders with expertise in image processing and machine learning. VIC Lab contributes to the academic field through the presentation of research papers and we are expected to improve our presentation skills, writing skills and expressive ability in their researches so that we can get international competitiveness.

Recent research achievements ('17~'19)

- [1] ICCV 2019, "Deep SR-ITM: Joint Learning of SR and Inverse Tone-Mapping for 4K UHD HDR Applications ", Oral Paper
- [2] MPEG LA – H.265 Patent Pool Original Licensor; H.265 standard Patents: 24
- [3] VIC Lab Wins First Place in the super-resolution track of ECCV's 2018 Mobile AI Competition.
- [4] VIC Lab Developed the world-first CNN-based real-time 2K-to-4KUHD@60fps super-resolution hardware (FPGA).



Robot Intelligence Technology Laboratory

Contact information

Professor : E3-2 #3235 TEL : 042-350-3448
 Lab. : E3-2 #3238, 3240 TEL : 042-350-8048, 8875
 Website : <http://rit.kaist.ac.kr>

Current state of the Lab. (in 2019 Fall Semester)

Postdoctoral Fellows : 3 PhD Students: 15 Master's Student: 9

Research Areas
Machine Interaction



Intelligent Interactive Technology

Intelligent Robot System

Emotional Memory Incremental Class Learning Visual Question Answering

Humanoid Robot **Mobile Manipulator**

Human-Robot Emotional Interaction and Collaboration

- Behavior selection and gaze control
- Situation understanding and semantic map reconstruction
- Emotion extraction with interactive GA and deep learning

Integrated Memory

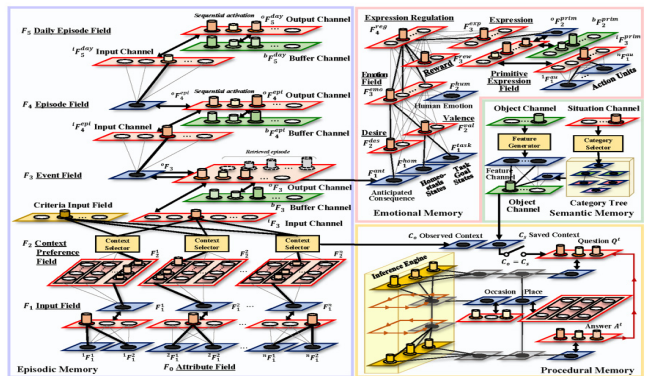

Anomaly Detection

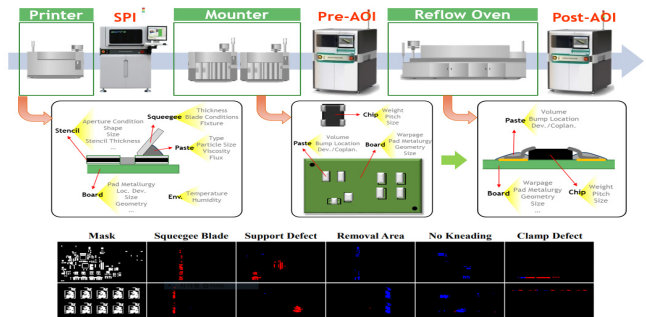

- SMT machine defect detection for smart factory
- Weld defect detection

Recommended courses & Career after graduation

We recommend EE682 Intelligent Control Theory, and EE788 Robot Cognition and Planning, and other machine/deep learning courses.

After graduation, our alumni work for universities, Samsung Electronics, LG Electronics, Agency for Defense Development, Electronics and Telecommunications Research Institute (ETRI), Korea Aerospace Research Institute (KARI), and Samsung Economic Research Institute (SERI), etc.

Introduction to other activities besides research

RIT lab. members enjoy various outside-lab activities such as retreats, sports, and movie watching.

Introduction to the Lab.

RIT Lab has proposed Soccer Robotics, Ubiquitous Robot, Genetic Robot, etc. Our research goals are multi-agent systems, developing "The Origin of Artificial Species," and an ubiquitous environment that incorporates software robots, embedded robots, and mobile robots. Also, our current research issues include development of episodic/semantic memory for task intelligence in humanoid robots, learning based on neural networks/affordance, and behavior selection based on confabulation/degree of consideration. Also, machine learning based artificial intelligence for digital companion and the industrial problems is being considered. We welcome the newcomer who is interested in robot intelligence, and machine learning.

Recent research achievements ('17~'19)

- [1] "3D Scene Graph: A Sparse and Semantic Representation of Physical Environments for Intelligent Agents," IEEE Trans. on Cybernetics, Jul. 2019.
- [2] "Recurrent Reconstructive Network for Sequential Anomaly Detection," IEEE Transactions on Cybernetics, Jul. 2019.
- [3] "Online Incremental Classification Resonance Network and Its Application to Human-Robot Interaction," IEEE Trans. on Neural Networks and Learning Systems, Jun. 2019.
- [4] "ART neural network-based integration of episodic memory and semantic memory for task planning for robots," Autonomous Robots, pp. 1-20, Jun. 2019.
- [5] "Leveraging Localization Accuracy with Off-centered GPS," IEEE Transactions on Intelligent Transportation Systems, May. 2019.
- [6] "Developmental Resonance Network," IEEE Trans. on Neural Networks and Learning Systems, vol. 30, no. 40, pp. 1278-1284, Apr. 2019.
- [7] "Short-Range Radar based Real-Time Hand Gesture Recognition Using LSTM Encoder," IEEE Access, vol. 7, pp. 33610-33618, Mar. 2019.
- [8] "Quick-RRT*: Triangular Inequality-based Implementation of RRT* with Improved Initial Solution and Convergence Rate," Expert Systems with Applications, Jan. 2019.
- [9] Top SCI Journals: 4(2017), 6(2018)

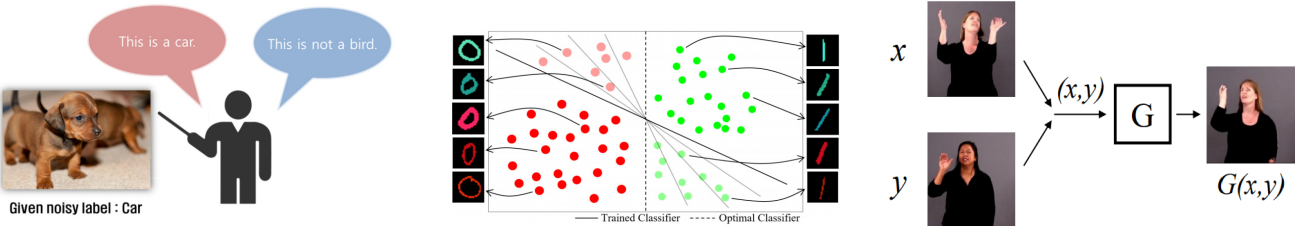
| | |
|--|--|
|  | <p>■ Contact information Professor : N1 ITC Building #210 TEL : 042-350-8088 Lab. : N1 ITC Building #214 TEL : 042-350-8088 Website : http://siit.kaist.ac.kr</p> |
| <p>■ Current state of the Lab. (in 2019 Fall Semester) Postdoctoral Fellows : 1 PhD Students: 24 Master's Student: 10</p> | |
| <p>■ Research Areas Our laboratory conducts research in areas such as image processing, computer vision, and machine learning, based on mathematical theories regarding probability & statistics, and information theory. It draws on various inferences and learning phenomena that occur in human brain and establishes mathematical theory related to reasoning and learning and develops various algorithms that computer can perform. Deep Neural Network, which has become a hot topic in recent years, addresses various computer vision tasks such as classification and detection, and explores and investigates various problems in the field of deep learning.</p> <p>[Current Research Topics]</p> <ul style="list-style-type: none"> - Research on Deep Neural Network : Network Compression / Neural Architecture Search - Applications of Computer Vision on Medical Imaging / Autonomous Driving - Expansion of Computer Vision on Video Analysis / Image Generation  | |
| <p>■ Recommended courses & Career after graduation Recommended courses are probability & statistics, machine learning, image understanding, and computer algorithms. Recent graduates entered IT companies or research institutes(Samsung Electronics, ETRI, Hyundai Motors, Naver, etc.). After postdoctoral course, they can work in domestic and international academia.</p> | <p>■ Introduction to other activities besides research We have a relaxing and enjoyable dining, a strawberry party in spring, a workshop in summer or winter, and a birthday party for all members. We encourage domestic or abroad internship. Also we support students to participate in various outside activities, not only on campus.</p> |
| <p>■ Introduction to the Lab. The SIIT laboratory is the best place to receive kind advise from the professor and enjoy free atmosphere. In this age of rapid technological development, we must deeply understand the fundamental theory that does not change, so that we can rapidly digest new technologies that are constantly pouring and create new knowledge. The SIIT focuses on training students to understand basic theories and apply them to real systems and implement them. In addition, we provide an opportunity to expand the scope of research and raise awareness of challenges, such as allowing a large number of research lab members to attend international conferences every year.</p> | |
| <p>■ Recent research achievements ('17~'19)</p> <ol style="list-style-type: none"> [1] Youngdon Kim et al., "NLNL: Negative Learning for Noisy Labels" (to be presented) in ICCV 2019 [2] Byungju Kim et al., "Learning Not to Learn: Training Deep Neural Networks with Biased Data" in CVPR 2019 [3] Yunho Jeon et al., "Constructing Fast Network through Deconstruction of Convolution" in NIPS 2018 [4] Donggyu Joo*, Doyeon Kim* et al., "Generating a Fusion Image: One's Identity and Another's Shape" in CVPR 2018 [5] Junho Yim et al., "A Gift from Knowledge Distillation: Fast Optimization, Network Minimization and Transfer Learning" in CVPR 2017 [6] Dongyoon Han*, Jiwhan Kim* et al., "Deep Pyramidal Residual Networks" in CVPR 2017 <p>(* denotes "equally contributed as the 1st author")</p> | |

| | |
|---------------------------------------|---|
| Computational Intelligence Laboratory | ■ Contact information Professor: (N1)413 TEL: 042-350-7421 Lab.: (N1)419 TEL: 042-350-7521 Website: http://cilabs.kaist.ac.kr |
|---------------------------------------|---|

| |
|--|
| ■ Current state of the Lab. (in 2019 Fall Semester) Postdoctoral Fellows : 0 Ph.D. Students: 17 Master Students: 8 |
|--|

■ Research Areas

Deep Network based Computer Vision



Long-term tracking

is the toilet lid closed -----?



yes, the bathroom is clean and ready to be used.

1 2 3 4 5

the toilet lid is not(closed), a bathroom with a toilet lid up and a white sink and black and white checkered tile floor.

1 2 3 4 5

Explainable AI

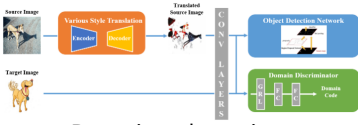

Domain adaptation

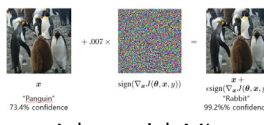

Adversarial ML

Medical Imaging

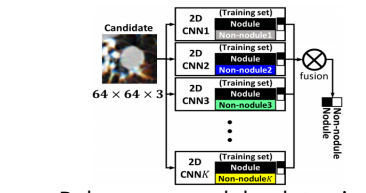

Pulmonary nodule detection

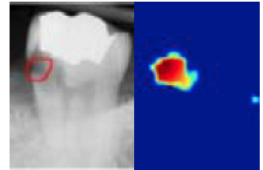

Dental caries detection

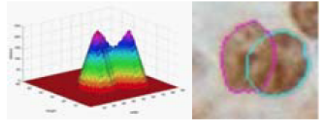

Overlapped nuclei segmentation

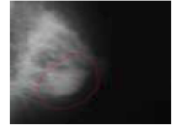

Cancer detection

Image Processing

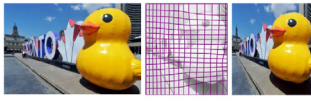

Image retargeting

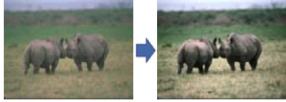

Image enhancement





Image deblurring



Shading removal

| |
|--|
| <p>Current Research Project</p> <ul style="list-style-type: none"> - Physically applicable adversarial attack on visual object tracking (2019.09.-2019.12.) - Faster and lighter object segmentation considering mobile AR service environment (2019.06.-2019.11.) - Development of QA system for video story understanding to pass Video Turing Test (2018.07.-2021.12.) - Development of AI-based Visual Tracking and Recognizing Algorithms (2018.02.-2020.01.) - Deep learning-based object classification in embedded systems (2018.02.-2020.01.) |
|--|

| | |
|---|---|
| <p>■ Recommended courses & Career after graduation</p> <ul style="list-style-type: none"> - Recommended courses: Signals & systems, Programming structure for electrical engineering, Probability and random processes, Introduction to multimedia, Pattern recognition, Linear algebra, Statistical learning theory, Image processing. - Career after graduation: Industry, National/International research institute, University, Post doctor. | <p>■ Introduction to other activities besides research</p> <p>The most representative activity of the CI lab is the homecoming-day meeting. In the annual event, most of our students and alumni are gathered and share the trends on various research/industrial fields. Above this, Prof. Changick Kim gladly encourages other activities such as summer/winter workshops and lab dinings.</p> |
|---|---|

| |
|--|
| <p>■ Introduction to the Lab.</p> <p>Since 2005, our laboratory has conducted a variety of projects and achieved a lot of academic advances. All of the lab members are highly self-motivated for exploring state-of-the-art research topics. Especially, our principal investigator, Prof. Changick Kim, constantly endeavors for graduate students so that they can effectively focus on the research activities.</p> |
|--|

| |
|---|
| <p>■ Recent research achievements ('17~'19)</p> <ul style="list-style-type: none"> - International Journal: 12 / International Conference: 17 [1] Hyukzae Lee, Chanhoo Jung, and Changick Kim, "Blind Deblurring of Text Images Using a Text-Specific Hybrid Dictionary," IEEE Transactions on Image Processing, 2019. [2] Seunghyeon Kim, Jaehoon Choi, Taekyung Kim, and Changick Kim, "Self-Training with Adversarial Background Regularization for Unsupervised Domain Adaptive One-Stage Object Detection," Accepted to International Conference on Computer Vision (ICCV), Seoul, Korea, 2019. [3] Jaehoon Choi, Taekyung Kim, and Changick Kim, "Self-Ensembling with GAN-based Data Augmentation for Domain Adaptation in Semantic Segmentation," Accepted to International Conference on Computer Vision (ICCV), Seoul, Korea, 2019. [4] Taekyung Kim, Minki Jeong, Seunghyeon Kim, Seokeon Choi, and Changick Kim, "Diversify and Match: A Domain Adaptive Representation Learning Paradigm for Object Detection," in Proc. IEEE Conference on Computer Vision and Pattern Recognition (CVPR), Long Beach, CA, USA, 2019. |
|---|

| | |
|---|---|
|  | <p>■ Contact information Professor : N24 (LG hall) 2111 TEL : #7417 Lab. : N24 (LG hall) 2111 TEL : #7617 Website : https://sites.google.com/site/sssclab</p> |
|---|---|

■ Current state of the Lab. (in 2019 Fall Semester)
 Full-time researcher : 1 PhD Students : 9 Master's Student: 4

■ Research Areas
 SSSCLAB has been researching pattern recognition based on machine learning and deep learning for speech and sound signals. In the mobile age, our research fields are expanding day by day: speech recognition/synthesis, speaker recognition, emotion recognition, and so on.

Speech Recognition is a technology that converts human speech into words or sentences. It helps humans communicate more naturally with computers or machines. In recent years, as the weight of speech recognition has increased in our lives due to the emergence of smartphones, AI speech devices, autonomous vehicles, and IoT devices, our laboratory has developed more effective and efficient speech processing methodologies.

In addition, we have studied a speaker recognition system for recognizing user's identity and natural language processing based language modeling to compensate syntactic consistency of recognized phoneme strings. We are also studying speech synthesis methodology that mimics the speaker's voice more naturally.

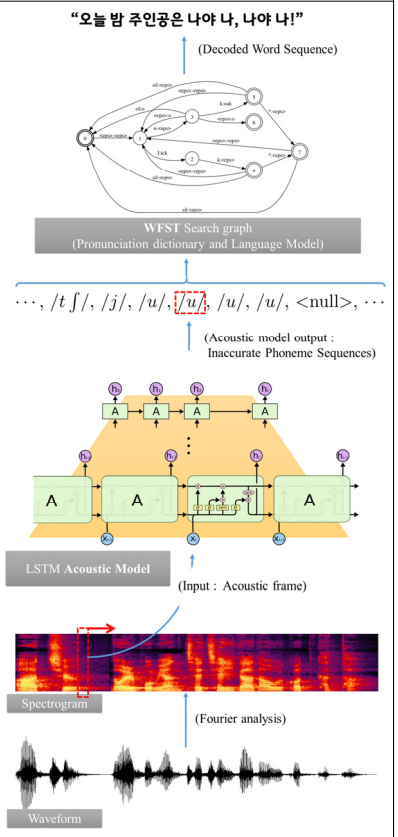

| Current Research Projects |
|---|
| Development of Distant Speech Recognition and Multi-Task Dialog Processing Technologies for In-Door Conversational Robots |
| Development of Conversational Speech Synthesis Technology to Express Emotion and Personality of Robots through Sound Source Diversification |
| Research for improvement of End-to-end Speech Recognition System |

■ Recommended courses & Career after graduation
 Highly recommended : Signals and Systems, Probability and Random Processes, and Digital Signal Processing.
 Recommended : As you like. (Linear algebra, Data structures and Algorithms, Information Theory, Deep Learning Theory, and etc.)
 Alumni have been entering not only big companies but also domestic and overseas research institutes and universities.

■ Introduction to other activities besides research
 SSSCLAB was founded in 2000. In 19 years of studying voice and audio signal processing, 8 Ph.Ds and 23 Master graduates have graduated. On top of research, we are sharing not only academic help but also enjoyment of everyday life through a strong bond between members based on a relaxed and free atmosphere. Furthermore, we are forming a very close relationship in the life and death relationship.



■ Introduction to the Lab.
 SSSCLAB carries out various projects related to voice and sound signal processing, and accumulates rich practical experience with it, and has achieved excellent academic research results. In addition, we provide a stable and strong financial support and a comfortable research environment so that students can continue their studies and research activities. Under the guidance of Professor Kim, Hoirin, we would like to ask you lots of creative and active new students who will be the future leaders of voice and sound signal processing.

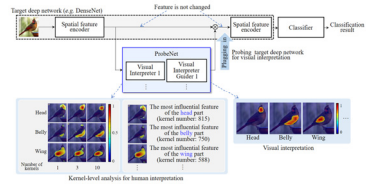
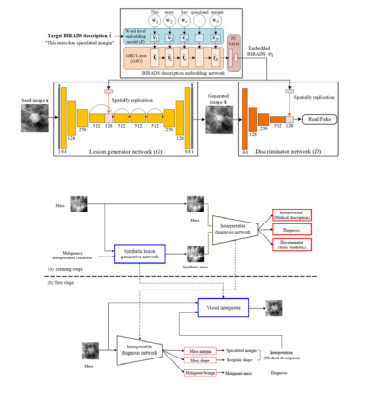
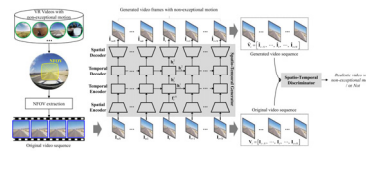

■ Recent research achievements ('17~'19, refer to SSSCLAB website)
 [1] Younggawn Kim et al., "Learning Self-Informed Feature Contribution for Deep Learning-Based Acoustic Modeling," IEEE/ACM TASLP, 26(11), Jul. 2018.
 [2] Youngjoo Suh and Hoirin Kim, "Histogram Equalization with Bayesian Estimation for Noise Robust Speech Recognition," JASA, 143(2), Feb. 2018.

| | |
|---|---|
|  <p>Image and Video Systems Laboratory</p> | <p>Contact information</p> <p>Professor : ITC building(N1) #414 TEL:+82-42-350-3494 Lab. : ITC building (N1) #418 TEL:+82-42-350-8094 Website : http://ivylab.kaist.ac.kr</p> |
| <p>Current state of the Lab. (in 2018 Fall Semester)</p> <p>Postdoctoral Fellows : 0 PhD Students: 9 Master's Student: 9</p> | |
| <p>Research Areas</p> <p>Deep learning algorithm in image processing/ computer vision</p> <p>Image/video analysis is an important research subject in the IVY lab, where deep learning approach is our current interest. We investigate various types of deep networks and devise new network structures to extract and analyze multi-modal data. Current research works in the lab include learning and representing the spatio-temporal dynamics in videos, facial expression recognition in very wild environments, facial landmark detection, abnormal event detection, object detection and tracking, video analysis (A number of the lab research results have been published in IEEE TIP, IEEE TAC, etc.)</p>  <p>Explainable (Interpretable) Deep learning: Medical image analysis</p> <p>Current research interest on medical image analysis is deep learning-based processing in medical images such as ultrasound, MRI and X-ray. Deep learning-based studies for attention network, adversarial learning, generative model and explainable AI have been done on medical images. This is an expansion of our earlier experience of establishing KAIST DBT CAD (computer aided diagnosis) system. Currently, we are conducting deep learning researches for latent lesion feature representation, lesion segmentation, Explainable Computer Aided Diagnosis(XCAD) in terms of medical doctor's terminology, and Text based medical image generation. (A number of the lab research results have been published in Med. Phys., Phys. Med. Biol., etc. Recently, we received Best Student Paper Award in CAD area at SPIE 2018)</p>  <p>3D/VR with deep learning approach: 3D Image/Video analysis</p> <p>In IVY Lab, we are studying the principle of 3D visual information, measurement of visual quality, and 3D virtual image generation technology. Recently, we have successfully developed more accurate visual quality and VR motion sickness evaluation technology using deep learning framework. Then, we are researching and analyzing the technologies that cause visual discomfort or VR motion sickness in 3D and VR virtual reality images. (A number of the lab Results have been published in IEEE TCSVT, IEEE TIP, Optics Express, etc.)</p>  | |
| <p>Recommended courses & Career after graduation</p> <p>Recommended courses include signals and systems, digital signal processing, machine learning, introduction to multimedia, image processing, various programming courses. Graduates have jobs in various places such as professor, post-doc(EPFL: Lausanne, Switzerland, TUM: Munich, Germany), national research institutes (ETRI, ADD), and companies (Samsung, Hyundai, SKT, etc.)</p> | <p>Introduction to other activities besides research</p> <p>The IVY laboratory regularly have common activities such as mountain tracking, summer/winter MT, etc. Please see various activities in http://ivylab.kaist.ac.kr/base/Gallery/Gallery.php</p> |
| <p>Introduction to the Lab.</p> <p>IVY laboratory was established in 1997. Our lab has achieved outstanding achievements such as this year's Science Prize (Association of Scientific Journalists), Best Paper Award, and IT Mark. The researchers have strong bonds with each other, and they help each other while researching and living in an autonomous atmosphere with stable support. We are also conducting researches on international senses through collaborations and visiting studies with foreign leading universities' research centers (University of Toronto, Ghent University, etc.) in the same research field.</p> | |
| <p>Recent research achievements ('16~'19)</p> <ul style="list-style-type: none"> - We have published 128 journal papers (SCI-indexed, referee peered), 290 International conference papers (referee peered). In recent 5 years, 48 SCI journal papers (IEEE TCSVT, IEEE TAC, IEEE TIP, PMB, etc.) and 72 International conference papers (ICASSP, ICIP, ECCV, AAAI, etc) have been published. Recent deep learning publication: http://ivylab.kaist.ac.kr/base/Publication/Publication.php - 23 Best paper awards in conferences and awards from Samsung humantech - IEEE International Conference on Consumer Electronics Asia (ICCE-Asia), Best Paper Award – Silver Prize (2018) - Computer-Aided-Diagnosis (CAD) conference on SPIE Medical Imaging (MI), Best Student Paper Award (2018) | |

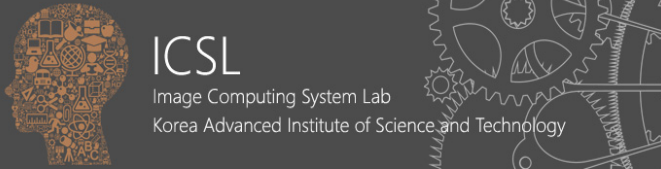
| | |
|--|---|
|  | <p>■ Contact information</p> <p>Professor : E3-2 #3236 TEL : 042-350-7451 Lab. : E3-2 #3239 TEL : 042-350-7551 Website : http://urobot.kaist.ac.kr/</p> |
| <p>■ Current state of the Lab. (in 2019 Fall Semester)</p> <p>Postdoctoral Fellows: 1 PhD Students: 15 Master's Student: 12 Researcher: 1</p> | |
| <p>■ Research Areas</p> <p>SLAM (Simultaneous Localization And Mapping) / Localization</p> <ul style="list-style-type: none"> - We are developing autonomous navigation (location estimation, mapping, path planning) technologies for various platforms such as mobile robots, unmanned aerial vehicles and self-driving cars. - The technology is developed based on the fusion of various sensors such as vision, IMU, LiDAR, UWB, magnetic sensors to perform robust navigation.  <p>Inspection Robots for Smart City</p> <ul style="list-style-type: none"> - We are developing an autonomous flight system of UAV for structural diagnosis in smart cities. - Focus on SLAM using multi-sensors such as camera, IMU, and 3D LiDAR mounted on UAV. - Our wall-climbing drone (CAROS) can be used for close inspection of civil structures such as bridges and high-rise buildings.  <p>Machine Learning & AI</p> <ul style="list-style-type: none"> - We are developing machine learning and artificial intelligence technologies for application to various fields. - Our lab focuses on vision-based object recognition technology using deep learning and also developing futuristic AI algorithms such as spike-inspired neural networks.  | |
| <p>■ Recommended courses & Career after graduation</p> <p>Recommended courses are related to robot control, signal processing, and intelligent systems. Control system engineering, intelligent robot experiment, linear algebra, machine learning, etc. Graduates usually get jobs at governmental or corporate research institute, start-ups, and universities.</p> | <p>■ Introduction to other activities besides research</p> <p>There are a variety of laboratory events including cultural and athletic activities, strawberry parties, birthday parties, summer/winter workshops, and homecoming day. Every year, workshops are used to build friendships between the advising professor and students.</p> |
| <p>■ Introduction to the Lab.</p> <p>Students can develop academic skills based on the professor's research guidance. There is also the opportunity to work on large scale projects by collaborating with students in various robotics fields. Besides, it encourages participation in the international conferences so you can grasp international trends in your major field and experience communication with many researchers.</p> | |
| <p>■ Recent research achievements ('17~'19)</p> <ul style="list-style-type: none"> - The Best Paper Award, ICROS (Institute for Control, Robotics, and Systems) Annual Conference, May 2019. - ISR (Intelligent Service Robotics) Journal Best Paper Award, June 28, 2018. - 2018 KAIST Synergic Research Prize, May 25, 2018. - Prime Minister's Citation Award at 2018 National Science Day, April 20, 2018. - SLAM technology transfer to three companies, 200M KRW, 2017 - 2018 - Hyungjin Kim, Seungwon Song, and Hyun Myung, "GP-ICP: Ground Plane ICP for Mobile Robots," IEEE Access, vol.7 no.1, pp.76599-76610, Dec. 2019. - Wancheol Myeong and Hyun Myung, "Development of a Wall-climbing Drone Capable of Vertical Soft Landing using a Tilt-rotor Mechanism," IEEE Access, vol.7, no.1, pp.4868-4879, Dec. 2019. - Byeolteo Park and Hyun Myung, "Resilient underground localization using magnetic field anomalies for drilling environment," IEEE Trans. Industrial Electronics, vol.65, no.2, pp.1377-1387, Feb. 2018. | |

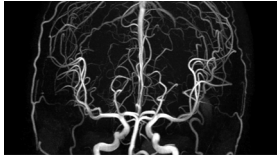
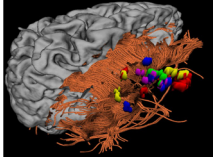
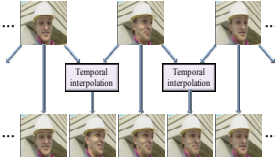
| | |
|--|--|
|  | <p>■ Contact information Professor: #4101 LG Innovation Hall TEL : 042-350-3475 Lab.: #4101 LG Innovation Hall TEL : 042-350-8075 Website: http://power.kaist.ac.kr</p> |
| <p>■ Current state of the Lab. (in 2019 Fall Semester) Postdoctoral Fellows : 0 PhD Students: 12 Master's Student: 4</p> | |
| <p>■ Research Areas Power Supply for Data Center Data center is increasing rapidly due to the extension of internet. Accordingly, power consumptions of data center is rising as a global issue. Therefore, this research proposes new technologies to obtain high efficiency and high power density of data center.</p> <p>Electrical Vehicle Charger Electrical vehicles essentially have rechargeable batteries that can be fully charged by connecting the vehicle plug to an external electric power source. Therefore, battery charger is one of the key components of EV.</p> <p>Battery Management System with Cell Balancing Circuit To increase the battery power, individual battery cell is connected in series-parallel structure. As the number of charging and discharging periods increase, the unbalanced cells are faced to the limit with the use of the battery power. Therefore, the cell balancing circuit is required to prevent the unbalances between the cell.</p> <p>Wireless Power Transfer System Wireless Power Charging System for large-capacity battery in electrical vehicles for a stable resonator with high efficiency.</p> |  <p style="text-align: center;">Data Center</p>  <p style="text-align: center;">EV Charger System</p>  <p style="text-align: center;">Battery Management System</p>  <p style="text-align: center;">Wireless Power Transfer</p> |
| <p>■ Recommended courses & Career after graduation Recommended courses: Circuit theory, Electronics circuits, Control system Career after graduation: Professors, Research institute, Company</p> | <p>■ Introduction to other activities besides research Exercise Activity : Soccer, Futsal, Basket ball, Foot volleyball Workshop : Summer and Winter workshop. Etc. : Year-end party and Home coming day.</p> |
| <p>■ Introduction to the Lab. KPEL is leading world-class power electronics researches. Main research area contains power supply for data center, charging system for electrical vehicle, wireless power transfer system, battery management systems. KPEL is contributing domestic company's sales with technical transfer by linking with industry. KPEL published 194 SCI journals, 279 international conferences, and 105 patents.</p> | |
| <p>■ Recent research achievements ('17~'19) International Journal (Total 23) 2019 : 8. (IEEE Trans. Power Electronics [I.F : 7.224] / IEEE Trans. Industrial Electronics [I.F : 7.503]) 2018 : 3. (IEEE Trans. Power Electronics [I.F : 6.812] / IEEE Trans. Industrial Electronics [I.F : 7.05]) 2017 : 7. (IEEE Trans. Power Electronics [I.F : 7.151] / IEEE Trans. Industrial Electronics [I.F : 7.168]) International Conference (Total 36) 2019 : 14. (ECCE Asia - Busan, APEC - USA), 2018 : 12. (ECCE Asia - Japan), 2017 : 10. (ECCE Asia - Taipei, APEC - USA) Domestic Conference (Total : 22 / 2019 : 5, 2018 : 8, 2017 : 9) Award (2017~2019) [1] "Highlighted Paper" 2019 IEEE Transactions on Power Electronics [I.F: : 7.224] [2] "Outstanding Presentation Award", IEEE International Applied Power Electronics Conference (IEEE APEC 2019) [3] Global Ph.D Fellowship Program (National Research of Foundation of Korea) [4] 24th, 25th Human Tech Paper Award (Samsung Electronics) : Bronze award [5] Korea Power Electronics Conference : 3 Best Paper, 4 best presentation</p> | |

| | | | | |
|--|--|--|--|--|
|  | <p>■ Contact information</p> <p>Professor's office : fMRI center (N23) TEL : 3466 Student office : fMRI center (N23) TEL : 8495 LG Hall #3105 (N24) TEL : 8066 Website : http://athena.kaist.ac.kr</p> | | | |
| <p>■ Current state of the Lab. (in 2019 Fall Semester)</p> <p>PhD Students: 6 Master's Student: 5</p> | | | | |
| <p>■ Research Areas</p> <p>- Magnetic resonance imaging We have our own state-of-art 3T MRI system on site, and are working on various MR imaging techniques such as fast imaging, reconstruction, motion gating, multi-contrast imaging, and RF design methods.</p> <p>- Artificial intelligence (AI) We are also investigating ways to apply AI in medical imaging such as fast imaging and correction of distortions induced by metallic implants and motions. We have recently been awarded "explainable human-like deep machine learning", which is 5-year long project with \$2M/year starting in 2017.</p> <p>- Functional magnetic resonance imaging There are also various multimedia stimulation and physiological monitoring devices available for functional MRI testing. Using the aforementioned devices along with high-resolution image reconstruction and statistical processing techniques, our group studies various neurological functions such as memory and emotion.</p> <p>- Frame rate up conversion (FRUC) We are also actively pursuing various technical issues in video processing. One issue is motion blurring that occurs when a video of low frame rate is shown on the holdon-type display. The problem can be alleviated by increasing the overall frame rate with FRUC, which synthesizes intermediate frames between the original video frames.</p> <div style="display: flex; justify-content: space-around; align-items: flex-end;"> <div style="text-align: center;"> <p>< 3T MRI system ></p>  </div> <div style="text-align: center;"> <p>< MR Angiography ></p>  </div> <div style="text-align: center;"> <p>< functional MRI ></p>  </div> <div style="text-align: center;"> <p>< Frame Rate Up Conversion ></p>  </div> </div> | | | | |
| <p>■ Recommended courses & Career after graduation</p> <p>The courses relevant to our research are "signals and system", "digital signal processing" and "image processing". Since the lab's foundation in 1993, 54 master's and 41 doctoral students have graduated and went on to work at various universities, national research centers, and companies such as Samsung and LG.</p> | <p>■ Introduction to other activities besides research</p> <p>Spring sports day, year-end party, and a new year's party are held annually for all alumni members and students.</p> | | | |
| <p>■ Introduction to the Lab.</p> <p>The image computing system lab researches on various technological challenges in the field of signal, image and video processing, such as medical image processing for new clinical use, and image and video processing technologies for next generation displays. With our long history, we offer various systematic structure for learning such as freshmen's seminars, video processing and medical imaging seminars that are held regularly and designed to facilitate discussions. Furthermore, we offer excellent research environment with ease of access to various research equipments such as 3T MRI system and high performance computing machines.</p> | | | | |
| <p>■ Recent research achievements ('17~'19)</p> <table style="width: 100%; border: none;"> <tr> <td style="vertical-align: top; width: 33%;"> <p>[1] In numbers</p> <ul style="list-style-type: none"> - Journal articles (int'l): 159 - Conference articles (int'l): 210 - Patents (domestic/int'l): over 163 </td> <td style="vertical-align: top; width: 33%;"> <p>[2] Awards</p> <ul style="list-style-type: none"> - Grand Prize at the 22nd Samsung HumanTech Paper award - Honours at various international conferences (ISMRM, ICMRI, etc.) </td> <td style="vertical-align: top; width: 33%;"> <p>[3] Major research achievements</p> <ul style="list-style-type: none"> - Fast MR imaging : MAGGULLI - Self-gated cardiac cine imaging - AI for medical imaging and FRUC </td> </tr> </table> | | <p>[1] In numbers</p> <ul style="list-style-type: none"> - Journal articles (int'l): 159 - Conference articles (int'l): 210 - Patents (domestic/int'l): over 163 | <p>[2] Awards</p> <ul style="list-style-type: none"> - Grand Prize at the 22nd Samsung HumanTech Paper award - Honours at various international conferences (ISMRM, ICMRI, etc.) | <p>[3] Major research achievements</p> <ul style="list-style-type: none"> - Fast MR imaging : MAGGULLI - Self-gated cardiac cine imaging - AI for medical imaging and FRUC |
| <p>[1] In numbers</p> <ul style="list-style-type: none"> - Journal articles (int'l): 159 - Conference articles (int'l): 210 - Patents (domestic/int'l): over 163 | <p>[2] Awards</p> <ul style="list-style-type: none"> - Grand Prize at the 22nd Samsung HumanTech Paper award - Honours at various international conferences (ISMRM, ICMRI, etc.) | <p>[3] Major research achievements</p> <ul style="list-style-type: none"> - Fast MR imaging : MAGGULLI - Self-gated cardiac cine imaging - AI for medical imaging and FRUC | | |

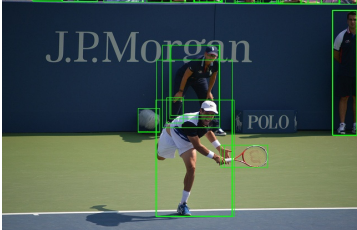
| | |
|--|---|
|    | <p>■ Contact information Professor : LG Hall (N24) #2109 TEL : 042-350-3470 Lab. : LG Hall (N24) #2106 TEL : 042-350-5470 Website : http://slsp.kaist.ac.kr</p> |
| <p>■ Current state of the Lab. (in 2019 Fall Semester) Research Associate Professor : 1 PhD Students: 9 Master's Student: 12</p> | |
| <p>■ Research Areas AIM Lab. focuses on machine learning algorithm and its applications using computer vision, audio processing, natural language processing, reinforcement learning and AI fairness.</p> <ul style="list-style-type: none"> ▶ Multi-modal Learning Video question answering, Visual question answering, Video understanding, Video categorization ▶ Computer Vision Instance Segmentation, Semantic Segmentation, Object detection, Object classification, Generative models for computer vision ▶ Reinforcement Learning Robot arm control, Drone control ▶ Theory of Machine Learning AI Fairness, Data augmentation, Meta-learning, Submodularity theory, Active learning |   |
| <p>■ Recommended courses & Career after graduation Laboratory graduates are active in a variety of fields. Graduates advance to overseas institutions such as Google DeepMind, MILA, Imperial College London, etc., and domestic institutions, such as Kakao Brain, Samsung Electronics, Qualcomm AI, etc.</p> | <p>■ Introduction to other activities besides research</p> <ul style="list-style-type: none"> - Sports day (outdoor activities; basket ball, badminton...) - Summer/Winter Membership training to beach/Skiing - New year's party with alumni members |
| <p>■ Introduction to the Lab. Using various machine learning theories including deep learning and signal processing techniques, video, image, text, speech, audio, robotic arm, and AI fairness are processed for longstanding and emerging applications. Currently, in charge of conducting research in understanding video (VTT center) and fairness in AI (AI fairness center)</p> | |
| <p>■ Recent research achievements ('17~'19)</p> <p>[C1] Sunghun Kang, Junyeong Kim, Hyunsoo Choi, Sungjin Kim and Chang D. Yoo, "Pivot Correlational Neural Network for Multi-modal Video Categorization", In European Conference on Computer Vision (ECCV), 2018.</p> <p>[C2] Junyeong Kim, Minuk Ma, Kyungsoo Kim, Sungjin Kim and Chang D. Yoo, "Progressive Attention Memory Network for Movie Story Question Answering", In Computer Vision and Pattern Recognition (CVPR), 2019.</p> <p>[C3] Jongmin Kim, Taesup Kim, Sungwoong Kim and Chang D. Yoo, "Labeling Graph Neural Network for Few-shot Learning", In Computer Vision and Pattern Recognition (CVPR), oral, 2019.</p> <p>[C4] Thang Vu, Hyunjun Chang, Trung X. Pham and Chang D. Yoo, "Cascade RPN: Delving into High-Quality Region Proposal Network with Adaptive Convolution", In Neural Information Processing Systems (NeurIPS), spotlight, 2019.</p> <p>● More research achievements including papers are presented in our homepage.</p> | |

| | |
|---|---|
|  <p>Neuro-Instrumentation and Computational Analysis Lab</p> | <p>■ Contact information Professor : LG Hall (N24) #4103-1 TEL : 042-350-7449 Lab. : LG Hall (N24) #4103 TEL : 042-350-7549 Website : http://www.nicalab.com</p> |
| <p>■ Current state of the Lab. (in 2019 Fall Semester) Postdoctoral Fellows : 0 PhD Students: 0 Master's Student: 2</p> | |
| <p>■ Research Areas</p> <p>Optical imaging of brain activity With genetic modification, the neurons can be modified to emit fluorescent light as a function of the brain activity (i.e., <u>neurons "blink" as they fire</u>) which makes the brain activity literally visible with an optical microscope. We develop and apply <u>high-speed 3-D imaging techniques</u> which will allow us to see how the neurons communicate. Keywords: optical microscopy, computational imaging, <i>in-vivo</i> experiment</p> <p>Computational analysis of brain structure Understanding a circuit involves knowing <u>how the elements are connected</u>. Most attempts and progress have been arising from analyzing electron microscopy images of a brain tissue. Our approach is to use optical microscopy which is fast, scalable and has the potential of self-labeling for machine learning (e.g., images can be used to perform supervised learning without any human labeling efforts). Keywords: neural network, image processing, connectomics</p> <p>Computational analysis of brain activity The first step is to <u>extract the brain activity from the video</u> which involves motion correction, artifact removal, cell segmentation/tracking, and deconvolution. After extracting the signal, we analyze the data to <u>identify repeating patterns</u> (motif detection) and/or to <u>infer the synaptic connectivity</u> which will be the basis of <u>functional connectomics</u>. Keywords: data mining, signal processing, functional connectomics</p> | |
| <p>■ Recommended courses & Career after graduation Recommended Signals and Systems(EE), Digital Signal Processing(EE), Machine Learning(CS), Optics(PH), Biomedical Optics(ME), Brain Science Fundamentals(BiS) Career All experiences and knowledge acquired during the graduate study can be directly transferred and applied to many biomedical jobs (both academia and industry) as well as data scientist positions.</p> | <p>■ Introduction to other activities besides research NICA members communicates with each other through lab dinners and strawberry parties. Lab members maintain good relationships through outside activities on a regular basis.</p> |
| <p>■ Introduction to the Lab. Our mission is to develop optical and computational technologies for brain and biomedical applications. More specifically, we think of a brain as a circuit that consists of neurons and devise new strategies to reverse engineer this circuit – through imaging/analyzing brain activity/structure. We are looking for the prospective students who are (a) self-motivated and (b) eager to explore new things.</p> | |
| <p>■ Recent research achievements ('14~'19) [1] Robotic multidimensional directed evolution of proteins: development and application to fluorescent voltage reporters, <i>Nature Chemical Biology</i>, 2018. [2] Iterative expansion microscopy, <i>Nature Methods</i>, 2017. [3] Simultaneous whole-animal 3D imaging of neuronal activity using light-field microscopy, <i>Nature Methods</i>, 2014.</p> | |

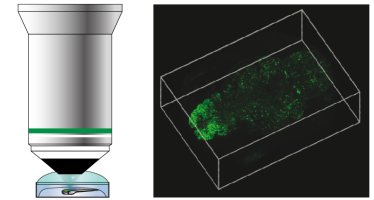



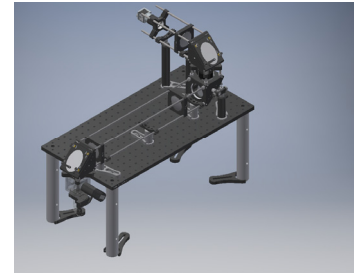

3-D optical imaging of brain activity

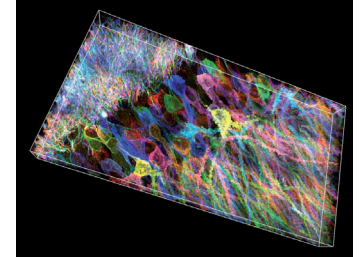

Optical design for brain imaging

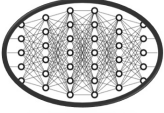

Brain structure imaging & analysis

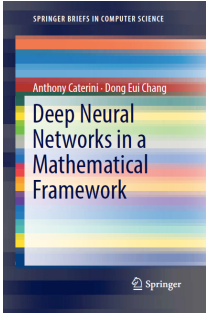
| | |
|---|---|
| <h1>Control Laboratory</h1> | <p>■ Contact information</p> <p>Professor : dechang@kaist.ac.kr TEL : 042-350-7440 Lab. : 5219, E3-2 TEL : 042-350-7540 Website : http://control.kaist.ac.kr</p> |
| <p>■ Current state of the Lab. (in 2019 Fall Semester)</p> <p>Postdoctoral Fellows : 0 PhD Students: 9 Master's Student: 7</p> | |
| <p>■ Research Areas</p> <p>We carry out research on control theory and apply it to robotics, machine learning and mechanics. As for real applications, we work on drones, robots, electro-mechanical systems and networks. The main tools used for our research include machine learning, Lyapunov theory, differential geometry, algebra, geometric mechanics, and optimization.</p> <p>■ Current Research Topics and Projects</p> <p>Control and Robotics</p> <ul style="list-style-type: none"> - Control of drones: We develop novel control algorithms for drone control and implement them on real drone systems. - Control of self-driving cars. - Feedback integrators: We develop numerical integration algorithms to faithfully preserve the values of conserved quantities such as energy during numerical integration. The results are not only interesting by themselves but also applicable to control theory and machine learning. - Control of robots: We work on humanoid robot control and relevant subjects such as robot vision, machine learning, etc. <p>Machine Learning</p> <ul style="list-style-type: none"> - We take a new approach to machine learning theory by applying control theory, differential geometry and advanced algebra, thus setting a higher stage for machine learning. - We recently received a research grant on machine learning-based software for digital companions. - We also work on Reinforcement Learning. <div style="display: flex; justify-content: space-around; align-items: center;"> <div style="text-align: center;">  <p>Control Theory</p> </div> <div style="text-align: center;">  <p>Deep Learning</p> </div> </div> <div style="display: flex; justify-content: space-around; align-items: center; margin-top: 10px;"> <div style="text-align: center;">  <p>Drones</p> </div> <div style="text-align: center;">  <p>Intelligence Vehicles</p> </div> <div style="text-align: center;">  <p>Robots</p> </div> </div> <div style="text-align: right; margin-top: 10px;">  </div> | |
| <p>■ Recommended courses & Career after graduation</p> <p>Research on control and robotics requires a strong background in mathematics, physics and computer science as well as electrical engineering. Recommended undergraduate courses are analysis, linear algebra, differential equations, mechanics, optimization, signals and systems, feedback control, visions, and machine learning.</p> <p>Graduates can work in academia, national labs or companies.</p> | <p>■ Introduction to other activities besides research</p> <p>There are no other activities done laboratory-wide than research.</p> |
| <p>■ Introduction to the Lab.</p> <p>Prof. Chang is an expert in control, mechanics and robotics. He recently moved from the University of Waterloo to KAIST. At KAIST, he is working on drones, self-driving cars, reinforcement learning and geometric integration. He takes students and post-docs from various fields including electrical engineering, mechanical engineering, aerospace engineering, brain science, computer science, and mathematics, thus creating a synergistic and multi-disciplinary research environment in the laboratory. Prospective students are not expected to have been exposed to all these areas. Only industriousness is required of them.</p> | |
| <p>■ Recent research achievements ('17~'19)</p> <ol style="list-style-type: none"> [1] 7th place in Alpha Pilot – Lockheed Martine AI Drone Racing Innovation Challenge Qualifier, 2019. [2] Feedback Integrators for Nonholonomic Mechanical Systems, <i>Journal of Nonlinear Science</i>, 2019. [3] Improved Reinforcement Learning through Imitation Learning Pretraining Towards Image-based Autonomous Driving, <i>ICCAS</i>, 2019. [4] Deep Reinforcement Learning Based Robot Arm Manipulation with Efficient Training Data through Simulation, <i>ICCAS</i>, 2019. [5] On controller design for systems on manifolds in Euclidean space, <i>International Journal of Robust and Nonlinear Control</i>, 2018. [6] Deep Neural Networks in a Mathematical Framework, Springer, 2018. | |

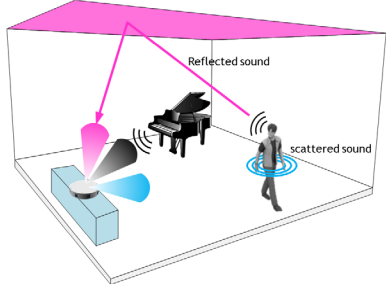
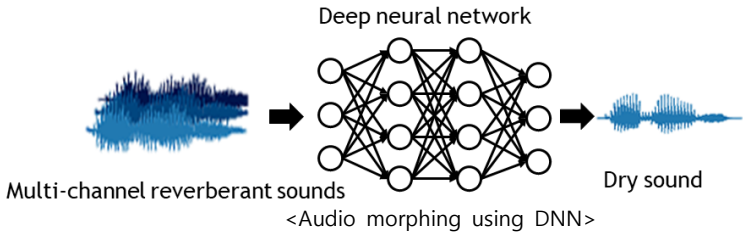
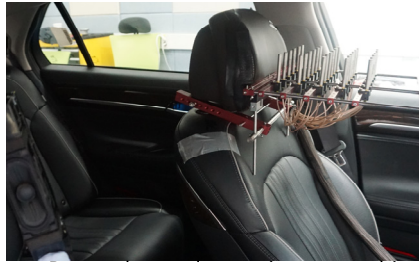
| | |
|--|--|
|  <p>Smart Sound Systems Laboratory</p> | <p>■ Contact information Professor : N24 LG Innovation Hall 2102 TEL : +82-42-350-7435 Lab. : N24 LG Innovation Hall 2103 TEL : +82-42-350-7535 Website : https://www.sound.kaist.ac.kr/</p> |
| <p>■ Current state of the Lab. (in 2019 Fall Semester) Postdoctoral Fellows : 1 Ph. D. Students: 3 Master Student: 5</p> | |
| <p>■ Research Areas</p> <p>The smart sound system laboratory has been doing research on holographic audio, sound field control and smart sound systems through acoustic, and audio signal processing. We study signal processing, sound field control techniques to control the shapes of physical waves (synthesis) or to extract useful information (analysis). Our research topics include the development of 3D audio for VR/AR applications, personal audio systems for creating independent sound zones in space, as well as intelligent audio systems that understand user behaviors and the environment by deep learning techniques.</p> <p>[Theory]</p> <ul style="list-style-type: none"> - Acoustics, Wave propagation - Array signal processing - Machine learning, Deep learning <p>[Applications]</p> <ul style="list-style-type: none"> - Holographic sound system, Telepresence - Wavefield synthesis, Sound field control - Environmental parameter estimation (Room geometry, user location, etc.) - Sound focusing, Personal sound zone - Beamforming, Localization, Underwater Imaging - Intelligent audio system with environmental awareness - Audio morphing through DNN |  <p><Audio system understanding user & environment></p>  <p>Multi-channel reverberant sounds → Deep neural network → Dry sound <Audio morphing using DNN></p>  <p><Personal sound zone in a car cabin></p> |
| <p>■ Recommended courses & Career after graduation</p> <p>We recommend signal processing based courses (Signals and systems / DSP), sound / vibration based courses (Acoustics / Array signal processing theory), and Deep learning courses. After graduation, you can further develop your career in IT related companies & research centers and sound & vibration control industries through research on sound and audio signal processing. You can also work in a wide range of fields, including Electric / Defense science, etc.</p> | <p>■ Introduction to other activities besides research</p> <p>Lab members regularly do yoga, play ping-pong, and learn to play musical instruments. By holding workshops with various subjects, we share our knowledge and promote fellowship.</p> |
| <p>■ Introduction to the Lab.</p> <p>The field of sound and vibration control is a multidisciplinary field that facilitates the integration of signal processing technologies with traditional technologies in communication / mechanical / aviation fields. The most important thing in the lab is the spirit of challenge to explore new fields without fear based on a strong theoretical foundation. Our laboratory pursuits regulation-free life to encourage creativity and self-motivatedness of members. Research on 'Intelligent Audio System with Environment Awareness' is being supported by the National Reserach Foundation of Korea (NRF). Personal sound zone system is being developed under the contract with Ministry of Trade, Industry and Energy (MOTIE).</p> | |
| <p>■ Recent research achievements ('17~'19)</p> <p>[1] "Dereverberation Based on Deep Neural Networks with Directional Feature from Spherical Microphone Array Recordings", in Proc. of the 23rd International Congress on Acoustics (ICA 2019). [2] "Direction of arrival estimation using nonsingular spherical ESPRIT," J. Acoust. Soc. Am., 143(3), Feb 2018. [3] "Spherical Harmonic Smoothing for Localizing Coherent Sound Sources," IEEE Trans. Audio and Speech Signal Processing, Vol. 25, No.11, pp 1969~1984, Aug 2017. [Article] https://bit.ly/2lDqP1t "車 앞좌석엔 '모나리자', 뒷좌석엔 '카르멘'만 들린다... 소리마법 빛어낸 '원원원원 협업'" [Awards] Best Student Paper Award (176th meeting of the Acoustical Society of America, Victoria, BC, Canada, 2018) Technology Innovation Award (College of Engineering, KAIST, 2018)</p> | |

| | |
|--|---|
|  <p>Speech and Audio Information Laboratory</p> | <p>■ Contact information</p> <p>Professor : Minsoo Hahn TEL : 042-350-3474 Lab. : N24 LG Hall, 3103 TEL : 042-350-5474 Website : http://sail.kaist.ac.kr</p> |
| <p>■ Current state of the Lab. (in 2019 Fall Semester)</p> <p>Postdoctoral Fellows : 0 PhD Students: 3 Master's Student: 0</p> | |
| <p>■ Research Areas</p> <p>Front-end for speech interface</p> <ul style="list-style-type: none"> - Noise reduction technique for robust HMI(Human-Machine Interaction) such as multi-channel beamforming, blind source separation, single-channel Wiener filter, Kalman filter, active noise cancellation. - Application: Smart TV, home robot, car navigation. <p>Statistical Parametric Speech Synthesis</p> <ul style="list-style-type: none"> - HMM-based Speech Synthesis for mobile devices. - Duration & Acoustic Modeling based on deep learning algorithm such as LSTM-RNN, Wavenet. - Linguistic & Acoustic Features for SPSS <p>Audio/Speech signal processing</p> <ul style="list-style-type: none"> - DNN-based Audio Scene Classification - High-quality multi-channel multi-object audio. - Vocal Harmonic Coding for SAOC (Spatial Audio Object Coding). - Cepstrum-based bandwidth extension for super-wideband codec. <p>Other fields</p> <ul style="list-style-type: none"> - Bio-signal processing techniques such as automatic assessment of pathological voice quality, puse transit time estimation, puse peak determination, etc. - Other speech sound source localization, sound texture coloring, binaural 3-D audio, sound field rendering, query by humming, VoIP packet loss concealment, voice color conversion, emotional speech. |  |
| <p>■ Recommended courses & Career after graduation</p> <ul style="list-style-type: none"> - Digital Signal Processing (EE432) - Digital Speech Processing (EE533) - Pattern Recognition (EE634) <p>Alumni works at university, enterprise institutes (Samsung, LG, SK) and national institute (ETRI, ADD).</p> | <p>■ Introduction to other activities besides research</p> <ul style="list-style-type: none"> - Various sports activity (Basketball, Football etc) - Mountain climbing - Annual workshop |
| <p>■ Introduction to the Lab.</p> <p>Speech and Audio Information Lab (SAIL) is the leading laboratory in Korea's speech and audio technology. We study speech and audio-related areas like noise reduction, speech synthesis, audio coding (MPEG) bio signal processing etc. As a result, we developed various noise reduction algorithm which can be applied in real-world situation. Also, we conducted research for high quality HMM-based speech synthesis. Now, our speech synthesis algorithm is embedded in many mobile phones. If you need more information, please contact us. Thank you.</p> |  |
| <p>■ Recent research achievements ('17~'19)</p> <p>[1] Speech Enhancement : "Speech Enhancement Using a Two-Stage Network for an Efficient Boosting Strategy," IEEE Signal Processing Letters, 2019. [2] Voice Activity Detection : "Voice Activity Detection Using an Adaptive Context Attention Model," IEEE Signal Processing Letters [3] Speech Synthesis : "Modulation Spectrum-constrained Trajectory Error Training for Mixture Density Network-based Speech Synthesis," 2018 [4] Emotional Speech : "Multi-speaker Emotional Acoustic Modeling for CNN-based Speech Synthesis," ICASSP 2019</p> | |

Wave Division





TeraByte Interconnection and Package Laboratory

■ **Contact information**

Professor: S-114-1, Nanofab Center E-mail: joungHo@kaist.ac.kr
 Lab: S-112, Nanofab Center E-mail: seungtaek@kaist.ac.kr
 Website: <http://tera.kaist.ac.kr>

■ **Current state of the Lab. (in 2019 Fall Semester)**

Research Professor: 1 PhD Students: 12 Master's Student: 7

■ **Research Areas**

Next Generation High Bandwidth Memory (HBM) for AI server

Recent demands on high data bandwidth, and density leads to remarkable development of silicon interposer-based 2.5D/3D integrated circuits (ICs). Due to fine silicon process and through silicon via (TSV) technologies, a 3D stacked high bandwidth memory (HBM) becomes a key solution which provides terabyte-per-second (TB/s) bandwidth. Our lab investigates the next generation HBM for AI server called processing-in-memory in HBM (PIM-HBM). We focuses on the design of PIM architecture and interconnections for PIM-HBM considering signal integrity (SI)/power integrity (PI).

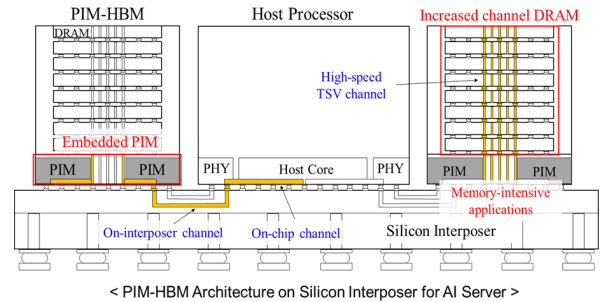

< PIM-HBM Architecture on Silicon Interposer for AI Server >

Machine Learning-based Signal/Power Integrity Design in 3-D ICs

Due to demands on higher performance, design complexity of the 2.5D/3D IC is gradually increasing to ensure the SI/PI. Moreover, time-to-market is getting shorter to respond market trends and customer needs. Therefore, time-efficient and accurate, optimal 2.5D/3D IC design method is necessary in these days. Our lab focuses on the implementation of the optimal SI/PI design for high-speed channels and power distribution networks based on machine learning techniques.

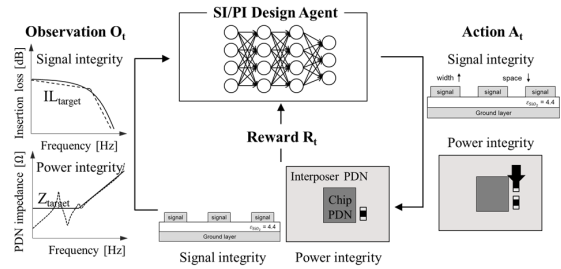

< Machine Learning-based SI/PI Design >

■ **Recommended courses & Career after graduation**

- Fundamental of electromagnetics and circuit theory.
- Graduates are currently in various global companies: Samsung Electronics, SK Hynix, Apple, Google, Nvidia, Intel, Tesla, Rambus, and etc.

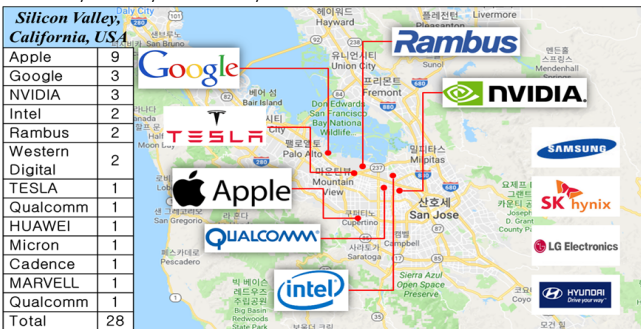

■ **Introduction to other activities besides research**

We encourage various extra-activities. Every week, we participate in activities such as soccer, e-sports and surfing. Every summer, we go to the beach for a laboratory workshop. Moreover, we are continuing good relations with graduates through frequent meetings and interactions.

■ **Introduction to the Lab.**

TeraByte lab is aiming for the cultivation of global talents, and many graduates have already started career in global companies. The research area is not only future-oriented and theoretical, but also practical by dealing with industry issues.



< Google Visiting Seminar >

■ **Recent research achievements ('17~'19)**

- [1] Best paper Award, Kyungjun Cho and et al., "Modeling and Analysis of Multiple Coupled Through-Silicon Vias (TSVs) for 2.5-D/3-D ICs" IEEE APMC 2019.
 - [2] Best paper Award, Seongsoo Lee and et al., "Design and Analysis of EMI Shielding Method using Intermediate Coil for Train WPT System" IEEE WPTC 2018.
- In addition, 19 International Journal Paper and 53 International Conference Paper in 2017-2019.



Contact information

Professor : E3-2, Room 4204 TEL : 042-350-7433
 Lab. : E3-2, Room 4210 TEL : 042-350-7633
 Website : <http://psrl.kaist.ac.kr>

Current state of the Lab. (in 2019 Fall Semester)

Postdoctoral Fellows : 3 PhD Students: 4 Master's Student: 5

Research Areas

We have been focusing our research activities on various aspects of photonic systems and related technologies, including high-capacity fiber-optic communication systems, broadband optical access systems, photonic sensor systems, fiber-optic mobile fronthaul/backhaul systems, and lightwave subsystems since 2014.

High-speed free-space optical transmission system

Due to the scarce resources of RF spectrum and growing demand for higher capacity, there is an increasing interest in the free-space optical communication (FSOC) system for commercial and military applications. For example, Google and Facebook have launched Project Loon and Aquila to extend internet connectivity to anywhere in the world by using FSOC-based balloons and drones, respectively. We are exploring the possibility of utilizing the FSOC technology for long-distance, high-capacity transmission.

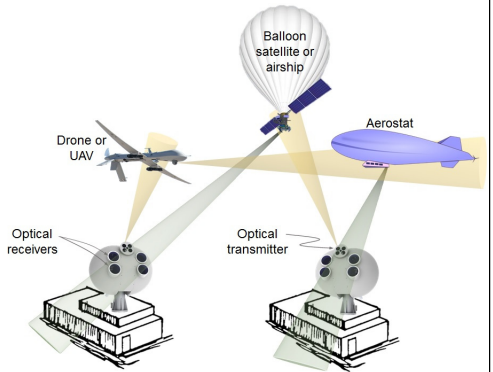

Transmission technologies for data center

There are strong demands for connectivity inside datacenters and between datacenters. Datacenter is a house of computer systems with storage, each interconnected with one another. There are >1 million optical transceivers in a large datacenter, delivering tens of gigabit data per second. We are focusing on various cost-effective technologies for datacenter applications. Some examples include 100G transmission using directly modulated laser (the simplest and most economical method for implementing optical transmission system), the Stokes-vector receiver and optical single-side band transmission using Kramers-Kronig direct-detection technique.

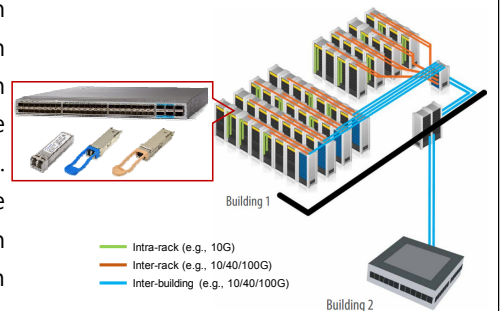

Recommended courses & Career after graduation

- (1) Recommended courses: Digital Communications, Introduction to Optical Communication, Introduction to Optical Engineering.
- (2) Potential career paths after graduation include national research institutes, major companies, and academia.

Introduction to other activities besides research

We plan to have an annual retreat among our team members in winter. We are also going to have a sports day regularly with other lab members in KAIST working on photonics.

Introduction to the Lab.

- (1) Photonics Systems Research lab was established in 2014. Under the supervision of Prof. Hoon Kim who has worked on photonics systems for 18 years in industry and academia including Bell Labs, Lucent Technologies, Samsung Electronics, and National University of Singapore, we research into the fundamental limits of various photonics systems as well as practical ways of implementing them.
- (2) Prof. Kim is currently serving as a Senior Editor of *IEEE Photonics Technology Letters* and an Associate Editor of *Optics Express*.
- (3) We carry out academic exchange with international research institutes and universities and also attend top-notch international conferences such as Optical Fiber Communications and OptoElectronic Communication Conference.

Recent research achievements ('17~'19)

- (1) International journal publications : 18, International conference presentations: 33.
- (2) SPIE Best Student Paper Award: OptoElectronics and Communication Conference 2018.
- (3) Best Student Paper Awards: Photonics Conference 2016, 2017, COOC 2016, 2018.

| | |
|---|--|
|  | <p>■ Contact information</p> <p>Professor : E3-2 Bld. Room #5206, TEL : 010-3412-1451 Lab. : E3-2 Bld. Room #5208 Website : http://ma.kaist.ac.kr</p> |
|---|--|

■ **Current state of the Lab. (in 2019 Fall Semester)**
 Postdoctoral Fellows : 2, PhD Students: 12, Master's Student: 5



■ **Research Areas**
 Research at Microwave and Antenna Laboratory includes electromagnetic theories for antenna analysis, developing antennas, radar systems, SAR, and radar target classification.

[Antenna Theory Analysis]
 We theoretically and numerically analyze electromagnetic phenomena induced by new materials like nano-materials and metasurface to apply a novel antenna technology.

[5G and beyond 5G Antenna Technologies]
 We develop a core technology of active antenna systems to design wide beam scan enhanced gain antenna, 5th generation mobile channel sounder system, and an accurate calibration with mmWave Antenna Measurement.

[Radar Surveillance System and Synthetic Aperture Radar(SAR)]
 We have realized and develop various radar systems, such as drone detecting system, an active electronic scanning radar, Synthetic Aperture Radar System, and radar target classification using deep learning technologies.

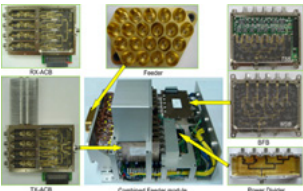
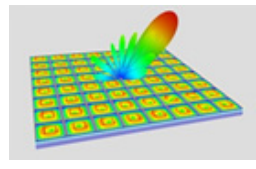
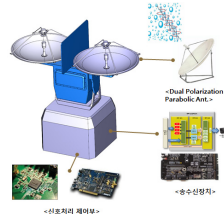
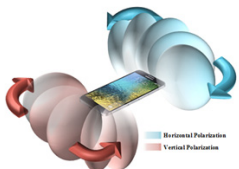
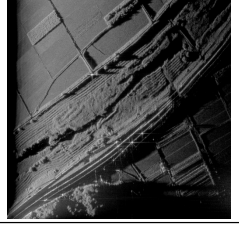
■ **mm-wave antenna and Radar Research Center for CubeSat**, supported by MIST(2018 7. 1 ~ 2024.12.29)
 The synthetic aperture radar(SAR) enables high-resolution, day-and-night and weather-independent observation, satellites constellation which enables to observe a particular location everywhere in the world in less than 20 minutes. Our research focuses on Ka-band deployable antenna and SAR radar payload on a 50 kg microsatellite. Ultimately, we are going to apply the SAR data to AI and Deep Learning technologies to predict and monitor natural disasters.

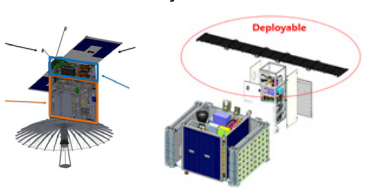
| | | | |
|---|---|--|---|
| <p><Antenna System ></p>  <p>< New antenna theory ></p>  | <p><Radar antenna & System></p>  <p>Air borne SAR Radar</p> | <p><5G Beam-forming antenna ></p>  <p>< SAR Radar Image></p>  | <p>< Auto SAR Radar Image ></p>  <p>< Cube Satellite SAR Radar System > Active Array Antenna</p>  |
|---|---|--|---|

| | |
|--|--|
| <p>■ Recommended courses & Career after graduation</p> <p>Electromagnetics, Electronic Circuits, and Signals and Systems are recommended for undergraduate courses. And for graduate courses, Electromagnetic Theory, Microwave Engineering, and Antenna Engineering are recommendable. After graduation, there are a wide range of career opportunities such as institutes, companies, schools, etc.</p> | <p>■ Introduction to other activities besides research</p> <p>We hold an annual Homecoming Day to promote interaction between students and alumni, and share information about academic research and industrial trends. Also, there are plenty of soccer matches to maintain a sound body and mind.</p> |
|--|--|

■ **Introduction to the Lab.**

Microwave and Antenna Laboratory have undertaken a number of government-sponsored projects. Based on accumulated research experiences, We pursue creative and future-oriented research. Prof. Seong-Ook Park makes leads us to write decent papers on key technologies of our fields. Moreover, the lab's atmosphere is fairly friendly and supportive, which is the greatest strength of our lab.

■ **연구 성과**

Recent research achievements ('15~'19)

- [1] International journal papers about 160, international conference papers about 130, domestic journals about 20, domestic conference about 30, and international/domestic patents of 28.
- [2] IEEE AP-S, IEEE EMC Korea Chapter, and etc, 5 best paper awards
- [3] Excellence evaluation A from National Research Foundation of Korea (NRF) in 2016.
- [4] Chosen as KAIST's Top 10 Research Achievements of 201, drone detecting radar system.
- [5] X-band Surveillance Radar System : Drone detection radar developed by Our lab (KAIST) was deployed and operated successfully at **2018 Pyeongchang Olympics**.

| | |
|---|---|
|  <p>Smart Sensor Systems Laboratory</p> | <p>■ Contact information</p> <p>Professor : E3-2 2223 TEL : 042-350-3453 Lab. : E3-2 2231 TEL : 042-350-5453 Website : http://sssl.kaist.ac.kr</p> |
|---|---|

■ Current state of the Lab. (in 2019 Fall Semester)

Ph.D Students: 6 Master's Student: 3

■ Research Areas

Our research areas are mainly focused on Si-photonics and integration nan o-photonics and nano-electronics. These areas are promising areas since they are available for high speed, low energy, small size, and high performance n ext-generation technology for chip/sensor/system.

▷ **Silicon nano-photonics phased-array antenna**

- Modern autonomous vehicles and robots require development of infrared beam-forming phased-array chip for Light Detection and Ranging(LiDAR)
- Laser scanning components are in urgent need of low power consumption and miniaturization to enable extensive utilization of LiDAR system.
- Silicon nano-photonics, which is developing rapidly, is the technology to reduce cost and area of devices with small sacrifice of their power efficie ncy.

▷ **Si-photonics-based photonic interconnection**

- Si-photonics device integration technology for multi CPU/memory chip-to- chip high speed/low power data transmission
- High-speed modulator, switch and router device design based on Si-phot onics
- Low cost chip packing technology for optical data transmission

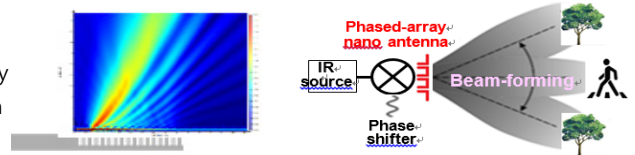

Figure 1. IR beam radiator using Nano-grating and beam forming application for image scanning

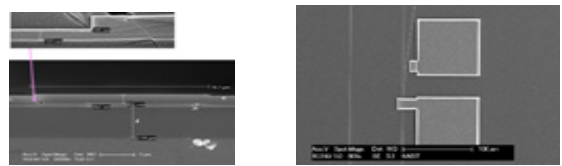

Figure 2. Optical phase shifter and waveguide switch based on Si-photonics

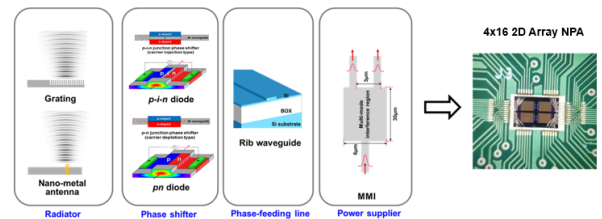

Figure 3. Optical phase shifter and waveguide switch based on Si-photonics

■ Recommended courses & Career after graduation

Engineering electromagnetics and physics of semiconductors courses are recommended for undergraduate students. It is okay to take the classes about the optics in graduate school. The alumni of the lab have got careers at Samsung Electronics, SK Hynix, Hyundai motors and national research institutes such as ETRI, KOPTI, DTAQ, and so on. Silicon photonics is promising research area to branch out the internationally leading company like Intel, IBM and Oracle and research institute.

■ Introduction to other activities besides research

We recommend golf and ski to strengthen our health and companionship. Annually, we have home coming day doing these sports activities and have a chance to interact with graduating seniors who works in variety of research institute.

■ Introduction to the Lab

Our lab is leading group in Si-Photonics research. From Si device design to fabrication, measuring, and packaging, we deal all these step. Through close cooperation with the National Nanofab Center(NNFC), CMOS compatible Si-photonics researches are actively underway. Based on our lab's outstanding optical interconnection module/platform technology, we have a favorable position in systemization and commercialization of technology. Si-photonics, the most promising technology to replace electrical connections in the future, is currently being studied by many companies, universities and laboratories around the world, and investment is also active. It has wide range of future possibilities. you may have competency in our lab.

■ Recent research achievements ('17~'19)

- [1] "Silicon-based OPA using electro-optic p-i-n phase shifters", Geumbong Kang et al, IEEE Photon. Tech. Lett, August 2019
- [2] "Thermo-optic control of the longitudinal radiation angle in a silicon-based optical phased array", Seong-Hwan Kim et al, Optics Letters, vol.44, no. 2, January 2019
- [2] "High-performance silicon MMI switch based on thermo-optic control of interference modes", Seong-Hwan Kim et al, IEEE Photon. Tech. Lett, vol. 30, no. 16, August 2018.
- [3] "Photon-assisted tunneling for sub-bandgap light detection in silicon PN-doped waveguides", Jong-Bum You et al, Optics Express, vol. 25, no. 4, February 2017.

■ Research projects in progress

- [1] Silicon-based opto-electronic interface technology for high-speed and low-power data transmission (2017~)
- [2] Development of heterogeneous many-core hardware systems for a next-generation high-performance computer (2017~)
- [3] Development of four-wavelength IR light source module for gas sensors (2017~)
- [4] Advanced BEOL technology using optical interconnection (2013~2018)

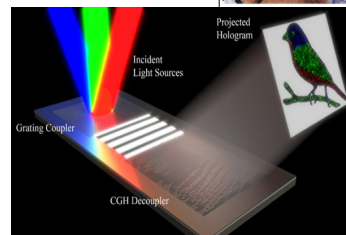
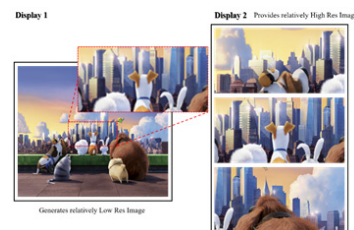
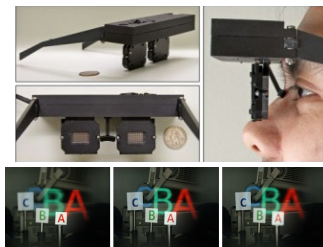

| | |
|---|--|
|  | <p>■ Contact information</p> <p>Professor : E3-2 3203 TEL : 042 350 7446 Lab. : E3-2 3215,16 TEL : 042 350 7446 Website : https://sites.google.com/view/qitkaist</p> |
| <p>■ Current state of the Lab. (in 2019 Fall Semester)</p> <p>Postdoctoral Fellows : 2 PhD Students: 1 Master's Student: 2</p> | |
| <p>■ Research Areas</p> <p>Quantum Information Theory - from Fundamentals to Applications</p> <p>Experiments on microscopic systems and its unusual and nonclassical phenomena in the 20th century lead to the birth of quantum theory, which is then formed as a mathematical theory that describes the microscopic world. The laws of quantum mechanics cannot be reproduced by other physical theories. When quantum principles are directly exploited to real-world applications, in particular, information and communication technologies (ICT), we will have quantum effects in technologies, that is, future ICT, beyond present-day's limitations</p>  <p>- Quantum protocols : Quantum protocols contains communication with qubits (quantum bits) and bits, where the former is called quantum communication and the latter classical communication. Quantum protocols can realize the information-theoretic security, enhance channel capacities, and open monogamous correlations in a network theory. Quantum protocols are based on resources, entanglement, quantum steering, and non-local probabilities.</p>  <p>- Quantum computation : Quantum dynamics is special in that it is restricted to linear and invertible transformations, allowing exponential increase of the dimension. This defines non-standard computation based on the laws of quantum mechanics and solve hard problems appearing in cryptographic applications. We develop the theoretical framework that overcome difficulties in realizing quantum computation.</p> <p>- Fundamental theories and mathematical tools : Information Theory, Applied Mathematics, and Theoretical Physics</p> <p>Algorithm and Complexity: Quantum vs. Classical</p>  | |
| <p>■ Recommended courses & Career after graduation</p> <p>Courses: probability, linear algebra, information theory, optimization, and introductory quantum information. All careers related with quantum information/ICT are open for future positions, academic jobs, business, and related companies.</p> | <p>■ Introduction to other activities besides research</p> <p>The group is international. There are postdoctoral researchers from abroad, and frequent visitors from Europe, Asia, and the US. We enjoy going out to eat. We will discover nice restaurants nearby.</p> |
| <p>■ Introduction to the Lab.</p> <p>Quantum Information Theory (QIT) studies how information is processed in the most fundamental level and characterizes capabilities of quantum systems in information processing. The group aims to advance QIT in a practical point of view. We're interested in feasible quantum information applications, developing its fundamentals, and theoretical tools to solve problems. We interact with computer scientists, mathematicians, and physicists.</p> | |
| <p>■ Recent research achievements</p> <p>[1] J. Bae, Designing Quantum Information Processing via Structural Physical Approximations, Rep. on Prog. in Phys., 80, 10 (2017). [2] J. Bae and D. Chruscinski, Operational Characterization of Divisibility of Dynamical Maps, Phys. Rev. Letts. 117, 050403 (2016).</p> | |

| | |
|---|---|
|  <p>Convergence Optoelectronic Device Engineering Lab.</p> | <p>■ Contact information</p> <p>Professor : E3-2 Room 5221 TEL : 042-350-3452 Lab : E3-2 Room 5232/5222 TEL : 042-350-5452/8052 Website : http://code.kaist.ac.kr [E-mail: yhwon@kaist.ac.kr]</p> |
| <p>■ Current state of the Lab. (in 2017 Spring Semester)</p> <p>Postdoctoral Fellows : 0 PhD Students: 9 Master's Student: 1</p> | |
| <p>■ Research Areas</p> <p>3D Image Display: Tunable Liquid-filled Microlens Array</p> <p>Recently, 3D display has been an issue, but there has been some problems in 3D display system such as relatively narrow viewing angle and tiredness of eyes. To solve these fundamental issues, CODE lab has developed liquid-filled microlens array. Specifically, researches on integral-imaging 3D display systems using the liquid microlens array have been mainly performed for high-resolution 3D image realization.</p> <p>High resolution & Wide viewing angle AR/VR display</p> <p>We have developed a novel foveated near-eye display system for ultra-high resolution and wide viewing angle. By integrating two displays and optical combiner, the resolution of near-eye display can be 4-5 times improved within the eye-gazing area. In addition, it is possible to implement the natural 3D environment by applying integral imaging system, which can provide realistic 3D image.</p> <p>Holographic display : signal processing and deep learning</p> <p>We are doing researches on efficient methods to make hologram pattern for 3D holography display. When light passes through the hologram pattern, a 3D image can be implemented at a desired position. In our lab, various methods of making hologram patterns such as segmenting an image or rearranging high frequency components have been studied. Recently, we succeeded in producing hologram patterns using deep learning. It is expected that this technology will be applied to AR systems and become the foundation technology of next generation 3D display platform.</p> | |
| <p>■ Recommended courses & Career after graduation</p> <p>Courses such as Electromagnetic Theory, Semiconductor Devices, Fundamentals of Photonics, Optical Electronics are recommended. After graduation, there is a chance for a career as professor, ETRI, KT, KEIT, Samsung, LG Display</p> | <p>■ Introduction to other activities besides research</p> <p>We participate actively in domestic and international conferences. Every students have an opportunity of presentation. Social activities such as membership training and homecoming events are held regularly.</p> |
| <p>■ Introduction to the Lab.</p> <p>We are currently doing researches about autostereoscopic display system with electrowetting vari-focal microlens array. This novel concept of 3D technology is selected for national project of ministry of knowledge economy, With focus variable lens system, many disadvantages of autostereoscopy like eye fatigue, narrow viewing region, low resolution can be enhanced dramatically. And also we are at forefront in optoelectronic devices area. Recently, we succeeded in fabricating hologram patterns using the Deep-Learning method. We have published many SCI journals and also presented various international conference presentations. In a harmonious atmosphere and state of the art research environment, students can focus on interesting research projects. You can have a wide experiences on various subjects with caring professor and passionate colleagues.</p> | |
| <p>■ Recent research achievements ('19)</p> <p>[1] "Low-noise high-efficiency double-phase hologram by multiplying a weight factor", Yoo Kwang Kim, Jin Su Lee, and Yong Hyub Son, <i>Optics Letters</i>, Vol. 44, Issue 15, pp. 3649-3652, June, 2019.</p> <p>[2] "Method to reduce the aberration of a polygonal aperture focus-tunable lens array for high fill factor", Junoh Kim, Jooho Lee, and Yong Hyub Won, <i>Optics Letters</i>, Vol. 44, Issue 10, pp. 2554-2557, May, 2019.</p> <p>[3] "Enhanced see-through near-eye display using time-division multiplexing of a Maxwellian-view and holographic display", Jin Su Lee, Yoo Kwang Kim, Mu Young Lee, and Yong Hyub Won, <i>Optics Express</i>, Issue 2, pp. 689-701, January, 2019.</p> | |

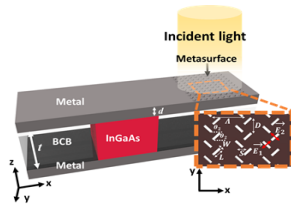
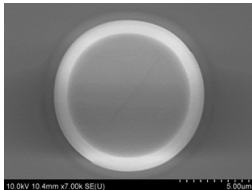

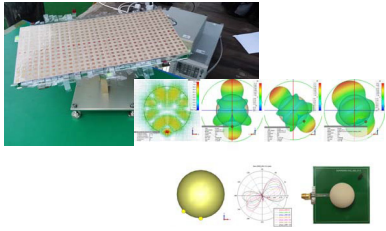
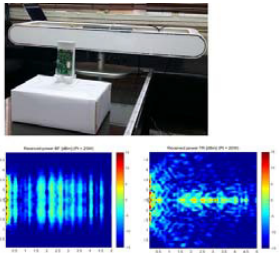
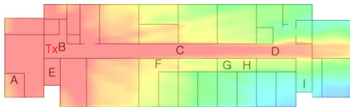
| | |
|---|---|
|  <p><Integrated Nanophotonics Laboratory></p> | <p>■ Contact information</p> <p>Professor : E3-3 #2307 TEL : 042-350-7415 Lab. : E3-3 #2302 TEL : 042-350-7515 Website : http://yu.kaist.ac.kr</p> |
| <p>■ Current state of the Lab. (in 2019 Fall Semester)</p> <p>Postdoctoral Fellows : 0 PhD Students: 7 Master's Student: 3</p> | |
| <p>■ Research Areas</p> <p>The Integrated Nanophotonics Laboratory is working on various topics on the fundamentals and applications of modern photonics/optoelectronics with special emphasis on integration and fabrication techniques using silicon, compound semiconductors, and emerging 2D materials. Especially, we are interested in device-level integration of photonics/optoelectronics for advanced information processing, display, sensing, and energy applications.</p> <p>Integrated photonics</p> <p>Silicon is the most well known material for electronics, but is also a promising optical medium at near-infrared wavelengths. By taking advantages of advanced fabrication and design techniques developed for electronic circuits, we can now design and build integrated photonic circuits that can complement and sometimes overcome the electronics in a number of cutting-edge applications, such as 'large-scale high-speed interconnects for chiplets', 'optical/wireless communication convergence for beyond 5G and terahertz era', 'high-precision time and frequency reference for quantum sensing', 'low-energy optical engines for large-scale linear optical information processing', and 'remote sensing and ranging for real-time environment monitoring'.</p> <p>Innovative photonic materials</p> <p>In addition to conventional group IV semiconductors and III-V compound semiconductor materials, recent innovations in materials research have significantly broadened the scope of modern photonics/optoelectronics. Our group is working on various emerging materials, such as 2D materials, hybrid materials, as well as metamaterials.</p> <div style="display: flex; justify-content: space-around; align-items: center;"> <div data-bbox="890 920 1182 1126">  </div> <div data-bbox="1209 938 1461 1126">  </div> </div> <div style="display: flex; justify-content: space-around; margin-top: 5px;"> <Photonic integrated circuit> <2D material resonator> </div> | |
| <p>■ Recommended courses & Career after graduation</p> <p>We recommend wave- and device-related courses, such as electromagnetics, semiconductor physics, and optoelectronics. Our 14 alumni members are currently at universities (UC Berkeley, U Toronto, Oxford), research institutes (ETRI, ADD), and industries (Samsung, and SK Hynix).</p> | <p>■ Introduction to other activities besides research</p> <p>We have regular summer and winter retreats, and workshops. We also regularly play soccer and badminton. These extracurricular activities are sometimes done with other laboratories with similar research interests.</p> |
| <p>■ Introduction to the Lab.</p> <p>Our research group is generally interested in micro-/nano-photonics, a highly interdisciplinary area with many emerging applications in information processing and quantum sensing. More specifically, integration of silicon- and 2D materials-based photonic/optoelectronic devices and systems for advanced information processing and sensing applications. Starting from micro-sized optical resonators to subwavelength-scale metamaterials and quantum optics, we cover a wide range of photonic/optoelectronic devices and systems for various applications.</p> | |
| <p>■ Recent research achievements ('17~'19)</p> <p>[1] "Optical analysis of the refractive index and birefringence of hexagonal boron nitride from the visible to near-infrared", <i>Optics Letters</i> (2019). [2] "Si-MoS₂ vertical heterojunction for a photodetector with high responsivity and low noise equivalent power", <i>ACS applied materials & interfaces</i> (2019). [3] "Ultra-high omnidirectional, broadband, and polarization-independent optical absorption over the visible wavelengths by effective dispersion engineering", <i>Scientific Reports</i> (2019). [4] "High-efficiency broadband light coupling between optical fibers and photonic integrated circuits", <i>Nanophotonics</i> (2018).</p> | |

| | |
|--|---|
|  <p>Radio Frequency System Solution Laboratory</p> | <p>■ Contact information Professor : EE B/D 5204 TEL : 042-350-3478 Lab. : EE B/D 5210 TEL : 042-350-5478 Website : http://rfss.kaist.ac.kr</p> |
| <p>■ Current state of the Lab. (in 2019 Fall Semester)</p> | |
| <p>Postdoctoral Fellows : 1 PhD Students: 14 Master's Student: 5</p> | |
| <p>■ Research Areas</p> | |
| <p>Our laboratory's goal is researching efficient and stable RF system in wireless communication environment. For that, we are analysing, researching RF system and antenna design. Depending on application, we make various RF frequency band system and improve its problems, issues. Today's research topics are RF energy harvesting, wireless power transmission using next generation wireless recharge standard, Smart antenna and massive MIMO antenna technique for next generation wireless communication, beam forming antenna technique about sending and receiving signal to where we want, NFC sending and receiving data in wireless, RFID, materialization wireless data communication system like bluetooth, etc.</p> | |
| <p>- Superdirective Dielectric Antenna & Phased Array Antenna System</p> <p>We research phased array antenna system for satellite communication. Phased array antenna system has feeding loss, combining loss and plenty of RF core chips because of many antennas. If we have high gain single element, we solve this problem. Therefore, we proposed and research superdirective dielectric antenna using higher mode. Also, we study issue of phased array antenna such as, calibration, beam tracking, management algorithm. For apply to automobile, we study on a small antenna system for vehicle supporting wide elevation angle.</p> |  |
| <p>- Wireless Power Transmission (Near-Field & Far-Field(Harvesting))</p> <p>Our laboratory develop wireless recharge system using A4Wp, Qi, NFC next generation wireless power transmission standard. Today, wireless recharge for mobile device's issues are space freedom making charger enable recharge on everywhere of it, Multiple charge with one charger. We apply wireless communication interface like bluetooth, so we can get not only wireless power transmission, but also data about charge amount, receiver's state remotely.</p> |  |
| <p>- Radio Propagation Characteristics Analysis</p> <p>In order to utilize new RF technologies such as IoT and 5G, it is necessary to analyze radio propagation characteristics in the frequency band. The main contents of the analysis are to predict radio propagation characteristics by reflecting indoor / outdoor radio wave environment characteristics such as reflection and diffraction by various structures, and to design transmission power and service range of wireless system. As a result, we present an efficient method of utilizing frequency.</p> |  |
| <p>■ Recommended courses & Career after graduation</p> <p>Recommended courses are electromagnetics, Radio engineering, antenna engineering, microwave engineering. Graduates are working at field of RF and mobile communication major company and national research center like Samsung electronics, Agency for Defense Development, ETRI.</p> | <p>■ Introduction to other activities besides research</p> <p>Our laboratory have activities(laboratory dining, exercise, MT etc) for friendship and unity periodically. Also we push ahead various activities(soccer, picnic, sports day) with other similar field laboratory in kaist for promoting friendship periodically.</p> |
| <p>■ Introduction to the Lab.</p> | |
| <p>Our laboratory's advantage is that you can accumulate lots of research experience through many kinds of assignment and group research in actual research environment. Also, graduates play an important role in the center of the team based on improved ability in laboratory. In addition, laboratory's environment doesn't lag behind other laboratories. If you are interested, passionate about our research field, you will never regret about choosing our laboratory.</p> | |
| <p>■ Recent research achievements ('17~'19)</p> | |
| <p>[1] K. Kim, G. Kim, S. Chae, H. Jo, J. Yu and H. L. Lee, "A Compact Circular Polarization Antenna Using Folded Ground Elements," in IEEE Transactions on Antennas and Propagation, vol. 67, no. 5, pp. 3472-3477, May 2019.</p> <p>[2] S. Khang, D. Lee, I. Hwang, T. Yeo and J. Yu, "Microwave Power Transfer With Optimal Number of Rectenna Arrays for Midrange Applications," in IEEE Antennas and Wireless Propagation Letters, vol. 17, no. 1, pp. 155-159, Jan. 2018.</p> <p>[3] T. Yeo, D. Kwon, S. Khang and J. Yu, "Design of Maximum Efficiency Tracking Control Scheme for Closed-Loop Wireless Power Charging System Employing Series Resonant Tank," in IEEE Transactions on Power Electronics, vol. 32, no. 1, pp. 471-478, Jan. 2017.</p> | |

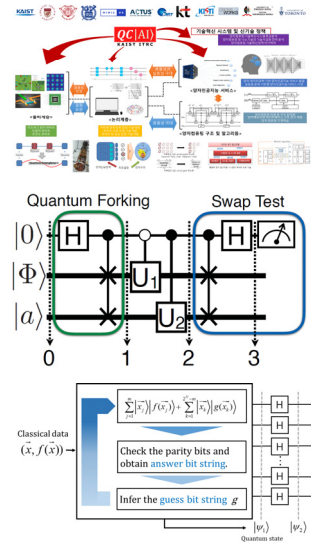
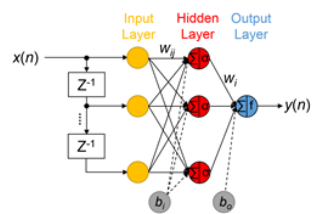
| | | |
|--|---|--|
|  <p>Quantum Information and Communications Lab</p> |  <p>KAIST IT Research Center of Quantum Computing for AI</p> | <p>Contact information</p> <p>Professor: EE building E3-2 3208 TEL: 042-350-7416 Lab.: EE building E3-2 3217 TEL: 042-350-7516 Website: http://quic.kaist.ac.kr</p> |
| <p>Current state of the Lab. (2019 Fall Semester)</p> <p>Research professor : 1 University-Industry Cooperation Professor : 1 Post-Doctor : 1 Ph.D Students : 3 Master's Students : 4</p> | | |
| <p>Research Areas QuIC: Uncover new ways of thinking in the Quantum IT World</p> <p>✓ Quantum Computing For Artificial Intelligence (ITRC Center, Est. 2018)</p> <p>Quantum computing has come true in a sense of proof of concept. Now it is rapidly growing to handle more complex problems such as AI, thanks to the recent developments of qubit (quantum bit devices) technologies by IBM, Google, and Intel, witnessing a strong potential to achieve complex computations superpolynomially faster than classical computing by using the qubits. Hence, a variety of researches are funded over a billion dollars in the world. QuIC Group has founded the KAIST IT Research Center of Quantum Computing for AI (QCAI), a national research program, in 2018. This center program fosters active research and education activities for master's and Ph.D. students as well as undergraduate students, in 10 research groups. QuIC Group is interested in two research topics in computing. In the area of quantum computing architecture, quantum algorithms can gain true quantum advantage only when handling the computing process and data interfaces in an efficient way. We study issues with quantum database (QDB), quantum forking (QFork), and quantum random access memories (QRAM). In the area of quantum machine learning, we started off the researches with a quantum parity learning algorithm, advancing with the applications for quantum reinforcement learning to find the intelligence-cummulative QML for the first time. Quantum AI will be the ultimate solution to reach human-level intelligent service for individuals at a very low cost and energy consumption.</p> <p>✓ Quantum Information Technology for Secure Quantum Key Distribution (QKD)</p> <p>Quantum communication channels can provide unconditional secure communications that cannot be heard even by the god. This quantum property can be understood by quantum information theory that deals with quantum phenomena in the framework of an information theory, and applied to QKD and quantum communications. QuIC is currently developing continuous variable QKD, and the enabling technology development for application with ground-satellite quantum channels studies.</p> <p>✓ Direct-detection Optical Access Network Enhanced by Machine Learning</p> <p>To meet the ever growing traffic load on cellular systems, cloud radio access network (C-RAN) has already drawn a lot of attentions to reduce inter-cell interference, energy consumption, and equipment cost. We study application of AI machine learning techniques to replace complex signal equalization to transmit >10 Gbps data with very nonlinear, low-cost laser diodes. We experimentally demonstrate the capacity expansion over 10 Gbps technical limit of laser diodes with four/eight-level pulse amplitude modulation (PAM-4 or 8). Later this effort will be applied to ground-satellite communications.</p> <div data-bbox="1189 443 1508 985">  <p>Quantum Forking and Swap Test diagrams showing quantum circuits and classical data processing steps.</p> </div> <div data-bbox="1189 1041 1508 1198">  <p>KAIST and HFR diagrams showing system architectures and components.</p> </div> <div data-bbox="1189 1276 1508 1489">  <p>Diagram of a neural network with Input Layer, Hidden Layer, and Output Layer, showing weights and bias terms.</p> </div> | | |
| <p>Recommended courses & Career after graduation</p> <p>Recommended courses are linear algebra, probability theory, quantum mechanics, information theory. Graduates have emancipated for various careers such as professors (Coventry U UK, IFSTTAR France), and researchers at major companies (Samsung, LIG Nex1, KT, ETRI, NSR).</p> | <p>Introduction to other activities besides research</p> <p>The Lab. actively encourages activities such as Leisure sports for membership among the member of the Lab. The members periodically play table tennis, badminton, bowling as well as workshops held twice in the year.</p> | |
| <p>Introduction to the Lab.</p> <p>Quantum Information and Communications (QuIC) Group with a vision to foster researches and educations of quantum computing and communications, as well as internet and communications, was founded in 2005. QuIC is currently working on researches seeking the first discovery of new ideas and the first implementation of new technologies in the area of quantum information and computing.</p> | | |
| <p>Recent research achievements</p> <p>[1] D.K. Park, I Sinayskiy, M Fingerhuth, F Petruccione, and J.K.K. Rhee, "Parallel quantum trajectories via forking for sampling without redundancy," New Journal of Physics, 2019. [2] D.K. Park, F Petruccione, and J.-K.K. Rhee, "Circuit-Based Quantum Random Access Memory for Classical Data," Scientific reports, 2019. [3] K. Lim, C. Suh and J.-K.K. Rhee, "Longer distance continuous variable quantum key distribution protocol with photon subtraction at the receiver," Quantum Information Processing 2019. [4] D.K. Park, J.-K.K. Rhee, S. Lee, "Noise-tolerant parity learning with one quantum bit," Phys. Rev. A, 2018.</p> | | |

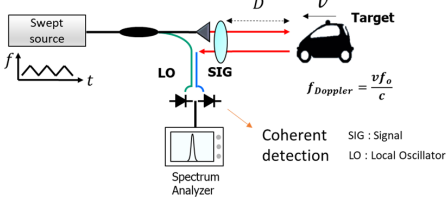
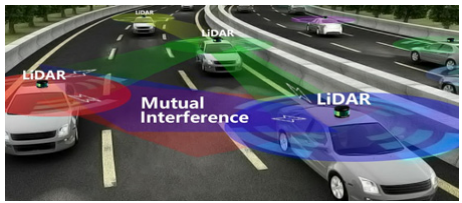
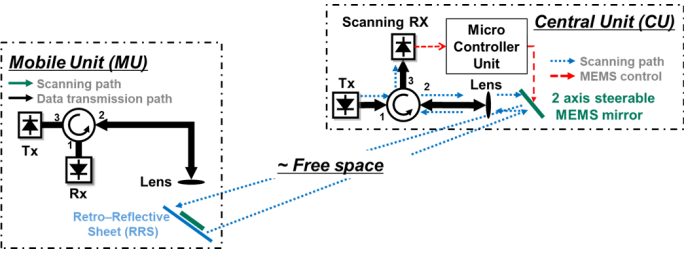
| | |
|---|---|
|  <p style="text-align: center;">LiDARs & Intelligent Optical Nodes Lab.</p> | <p>■ Contact information</p> <p>Professor : #5225 E3-2 TEL : 042-350-3463 Lab. : #5227 E3-2 TEL : 042-350-5463 Website : http://lion.kaist.ac.kr</p> |
| <p>■ Current state of the Lab. (in 2019 Fall Semester)</p> <p>Postdoctoral Fellows : 0 Ph.D. Students: 5 Master's Student: 5</p> | |
| <p>■ Research Areas</p> <p>- LiDAR (Light Detection and Ranging) Recently, demands for LiDARs, which had mostly been used for aerospace, satellite, atmospheric areas, have been increasing as an indispensable element for a self-driving car. The LiDAR is designed to measure distance to a target by sending optical pulses. We are focusing on not only developing of 3D LiDAR systems based on the optical beam steering techniques, but also applications of LiDARs to the self-driving cars.</p>  <p>- LiDAR without mutual interference for autonomous vehicles LiDAR is one of the most important sensors for autonomous vehicles. However, it interferes each other. The interference causes errors in sensing (detection of other cars, pedestrians, and obstacles) and strong interference may be unable to use it. Then, it will bring very harmful impacts. So, development of a LiDAR without mutual interference is one of the most important issues for autonomous vehicles.</p>  <p>- Communication based on machine learning In an Elastic Optical Network (EON), bandwidth is allocated differently for a different modulation format dependent on channel conditions or transmission speeds due to a limited bandwidth of an optical amplifier and fiber. Therefore, a receiver does not guarantee that a received signal has the same modulation format in the EON. In order to demodulate the received signal, it is needed to identify the modulation format of the received signal.</p> <p>- Free-space optical communication An optical wireless communication will be a key technology for a wireless connection with a unlimited bandwidth. A remarkable directivity of the light enables a very long distance transmission with a very high bandwidth. These features are important to solve saturation of the bandwidth in a RF based wireless communication. We are covering automatic alignment techniques, modulation on optical vortices, machine learning-based performance improvement and security.</p>  | |
| <p>■ Recommended courses & Career after graduation</p> <p>Electromagnetism, Optics, Photonics, Optical Electronics, Optical engineering, Optical communications, Solid state electronics, Semiconductor devices, Digital Signal processing, Antenna, Electric circuits and etc.</p> <p>The alumni of LION continues their research in global companies (Samsung, LG, KT, etc.), government funded research centers (ETRI, ADD, etc.), or prestigious universities as a post-doc or professor.</p> | <p>■ Introduction to other activities besides research</p> <p>We encourage physical activities for your healthy life. We play table tennis, soccer, bowling and weight training sometime. You can join us if you want. Additionally, we have book review on various categories for widely enlarging our knowledge.</p> |
| <p>■ Introduction to the Lab.</p> <p>Professor Lee was appointed as IEEE Fellow in 2010. Additionally, one of our projects, a low-noise multi-wavelength optical source, was selected as a top result among 100 selected researches in 2014. From the Chinese government, he was selected to "The Thousand Talents Plan". We are planning to research with labs and companies in China. Students will have a lot of chances to explore China.</p> | |
| <p>■ Recent research achievements ('16~'18)</p> <p>[1] International journal : 4 / International conference : 6 [2] "The Thousand talents Plan" – China government (2017)</p> | |

| | |
|----------------------------|---|
| <h1>Nanophotonics Lab</h1> | ■ Contacts PI : E3-2 #2221 TEL : 042-350-7439 Lab : E3-2 #2222, #2232 TEL : 042-350-7539 Homepage : janglab.org Email : jang.minseok@kaist.ac.kr |
|----------------------------|---|

■ **Current member status (2019 Fall): # of Post-docs:** 2, PhD: 5, Masters: 5

■ **Research Areas**

We understand the properties of light in ultra-small, subwavelength scales and develop technologies which manipulates them to suit our needs.

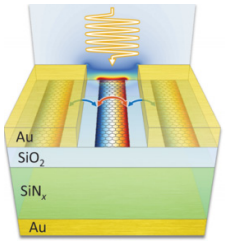

Plasmonic nanostructures: Free space photons and electrons in the metal interact at the metal's interface and light gets concentrated into very small volumes. Recent advancements with graphene (instead of metal) have yielded light concentration to a greater degree. Such phenomena opens up possibilities of ultrafast and microscopic photonic switches and mid-infrared sensors and sources.

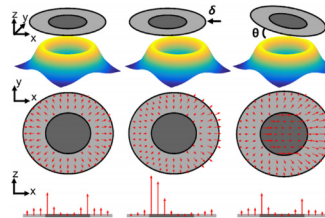

Metasurfaces: Using nanoarray structures that are smaller than the wavelength of light, artificial materials called metasurfaces with novel optical properties constitute one of the main pillars of the field of nanophotonics. Using these metasurfaces, we are currently developing wavefront tuning technologies with spatial resolutions smaller than the wavelength scale.

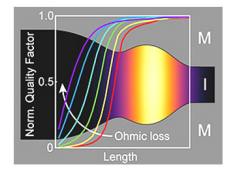

Computation photonics: Because the need for nano structures with specific/optimized functionalities is increasing, our team is working on inverse design methodologies utilizing various optimization schemes like genetic algorithms and neural networks

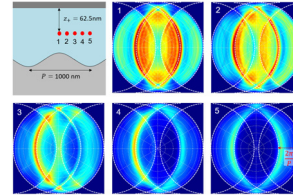

Displays: The goal is to analyze the light distribution inside OLED components and minimize light losses. Furthermore, we are working on adapting OLED devices for virtual/augmented reality displays which require ultra-high-def resolutions.

■ **Recommended courses and Potential career paths**

Theoretical research: To analyze and design photonic device functionalities, courses such as 'Electromagnetics', 'Quantum mechanics', and 'Fundamentals of photonics' are recommended.

Experimental research: The following courses 'Introductions to physical electronics', 'Semiconductor devices', 'Semiconductor IC technology', etc. are recommended to prepare oneself for fabrication of photonic devices.

There's a lot of demand for nanophotonics in both academia and industry, and diverse career paths are possible, whether it be researching in academia or working on display technologies at an industry.

■ **About our lab and prospective team members**

We are currently accepting undergrads who want a research experience in a lab. What we offer:



- (1) Research along **the interface between science and engineering:** Understand the fundamentals behind physical phenomena, and apply it for engineering purposes.
- (2) You can choose between theory/simulations or experiment, or both, depending on your aptitude or preferences.
- (3) Collaboration with other labs abroad.

Our lab prides in our friendly and horizontal lab culture and student-driven researches. We respect every student's own times and schedules, and provide an academic environment to study and research in at one's own needs.

* **About the PI:** I myself was a KAIST undergraduate, class of 2006, who took classes in the same rooms of KAIST and did internships and undergrad research programs, developing my skills as a researcher. Also, having very recently graduated from graduate school, I understand very well the difficulties and problems graduate students go through. I take as a top priority to lead a lab that's the most beneficial for our members, and will try my hardest in **helping students find the research topics of their interest** and **creating a non-authoritative lab atmosphere blooming with fruitful discussions.**

■ **대표 연구 성과 소개 ('18~'19)**

- [1] "Ultimate light trapping in a free-form plasmonic waveguide," Physical Review Applied (2019).
- [2] "Self-stabilizing laser sails based on optical metasurfaces," ACS Photonics (2019).
- [3] "Modulated resonant transmission of graphene plasmons across a $\lambda/50$ plasmonic waveguide gap," Physical Review Applied (2018).
- [4] "Mixed Valence Perovskite Cs₂Au₂I₆: A Potential Material for Thin-Film Pb-Free Photovoltaic Cells with Ultrahigh Efficiency", Adv. Materials (2018).
- [5] "Electronically Tunable Perfect Absorption in Graphene", Nano Letters (2018).

| | |
|--|--|
|  <p>Lightwave Systems Research Laboratory</p> | <p>■ Contact information</p> <p>Professor : 4206, E3-2 TEL : 042-350-3456 Lab. : 4205, E3-2 TEL : 042-350-8056 Website : http://optolab.kaist.ac.kr</p> |
| <p>■ Current state of the Lab. (in 2019 Spring Semester)</p> <p>PhD Students: 3 Master's Student: 0</p> | |
| <p>■ Research Areas</p> <ul style="list-style-type: none"> • Optical transmission for long-haul network: <ul style="list-style-type: none"> - Research for high-capacity network (beyond 100 Tb/s/fiber) - Research for ultra-long distance transmission (>1000 km) - Development of novel optical modulation formats - Development of novel algorithm at the receiver (digital signal processing) - Development of technique for optical performance monitoring - Demonstration of wavelength division multiplexed transmission (>400 Gb/s/channel) - Development of technique for suppress the nonlinear phenomena in optical fiber to increase the capacity • Spatial division multiplexed transmission: <ul style="list-style-type: none"> - Research for spatial division multiplexed transmission to increase the channel capacity - Demonstration of mode division multiplexed transmission through multi-mode fibers - Demonstration of spatial division multiplexed transmission through multi-core fibers - Development of signal processing technique to suppress the crosstalk between channels • Transmission in optical fronthaul network for 5G / Next generation passive optical network for access network : <ul style="list-style-type: none"> - Research for FTTH (fiber-to-the-home) - Suggestion of plausible transmission scenario for optical fronthaul network  | |
| <p>■ Recommended courses & Career after graduation</p> <ul style="list-style-type: none"> - Recommended course: digital communication, optical communication, photonics - Most of our graduates are professors, researchers at government-funded research institute (ETRI, ADD, and so on) and private company (Samsung, LG, KT, and so on). | <p>■ Introduction to other activities besides research</p> <ul style="list-style-type: none"> - Home coming day: once a year - Optical society of America (OSA) KAIST chapter |
| <p>■ Introduction to the Lab.</p> <ul style="list-style-type: none"> - We have a lot of state-of-the-art equipment (including 160-GSample/s oscilloscope, 92-GSample/s arbitrary waveform generator). - Co-work with Bell labs, KDDI R&D labs, Huawei technology - Co-work with ETRI | |
| <p>■ Recent research achievements</p> <ul style="list-style-type: none"> - Professor Chung was a general chair of the OFC 2014 conference which is the largest global conference and exhibition for optical communications and network professionals. - 30 papers for international conference - 16 papers for international journal - Best student awards (Photonics conference 2015, COOC 2016, OECC 2016) | |

Campus Map



